

**SUZUKI**

***DL650***

**SERVICE MANUAL**



99500-36130-03E

## FOREWORD

This manual contains an introductory description on the SUZUKI DL650 and procedures for its inspection/service and overhaul of its main components. Other information considered as generally known is not included.

Read the GENERAL INFORMATION section to familiarize yourself with the motorcycle and its maintenance. Use this section as well as other sections to use as a guide for proper inspection and service. This manual will help you know the motorcycle better so that you can assure your customers of fast and reliable service.

\* This manual has been prepared on the basis of the latest specifications at the time of publication. If modifications have been made since then, differences may exist between the content of this manual and the actual motorcycle.

\* Illustrations in this manual are used to show the basic principles of operation and work procedures. They may not represent the actual motorcycle exactly in detail.

\* This manual is written for persons who have enough knowledge, skills and tools, including special tools, for servicing SUZUKI motorcycles. If you do not have the proper knowledge and tools, ask your authorized SUZUKI motorcycle dealer to help you.

### **▲ WARNING**

Inexperienced mechanics or mechanics without the proper tools and equipment may not be able to properly perform the services described in this manual. Improper repair may result in injury to the mechanic and may render the motorcycle unsafe for the rider and passenger.

## GROUP INDEX

<b>GENERAL INFORMATION</b>	<b>1</b>
<b>PERIODIC MAINTENANCE</b>	<b>2</b>
<b>ENGINE</b>	<b>3</b>
<b>FI SYSTEM DIAGNOSIS</b>	<b>4</b>
<b>FUEL SYSTEM AND THROTTLE BODY</b>	<b>5</b>
<b>COOLING AND LUBRICATION SYSTEM</b>	<b>6</b>
<b>CHASSIS</b>	<b>7</b>
<b>ELECTRICAL SYSTEM</b>	<b>8</b>
<b>SERVICING INFORMATION</b>	<b>9</b>
<b>EMISSION CONTROL INFORMATION</b>	<b>10</b>
<b>WIRING DIAGRAM</b>	<b>11</b>

**SUZUKI MOTOR CORPORATION**

## HOW TO USE THIS MANUAL TO LOCATE WHAT YOU ARE LOOKING FOR:

1. The text of this manual is divided into sections.
2. The section titles are listed in the GROUP INDEX.
3. Holding the manual as shown at the right will allow you to find the first page of the section easily.
4. The contents are listed on the first page of each section to help you find the item and page you need.

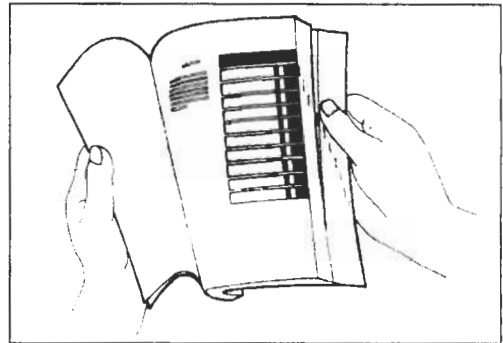

## COMPONENT PARTS AND WORK TO BE DONE

Under the name of each system or unit, is its exploded view. Work instructions and other service information such as the tightening torque, lubricating points and locking agent points, are provided.

Example: Front wheel





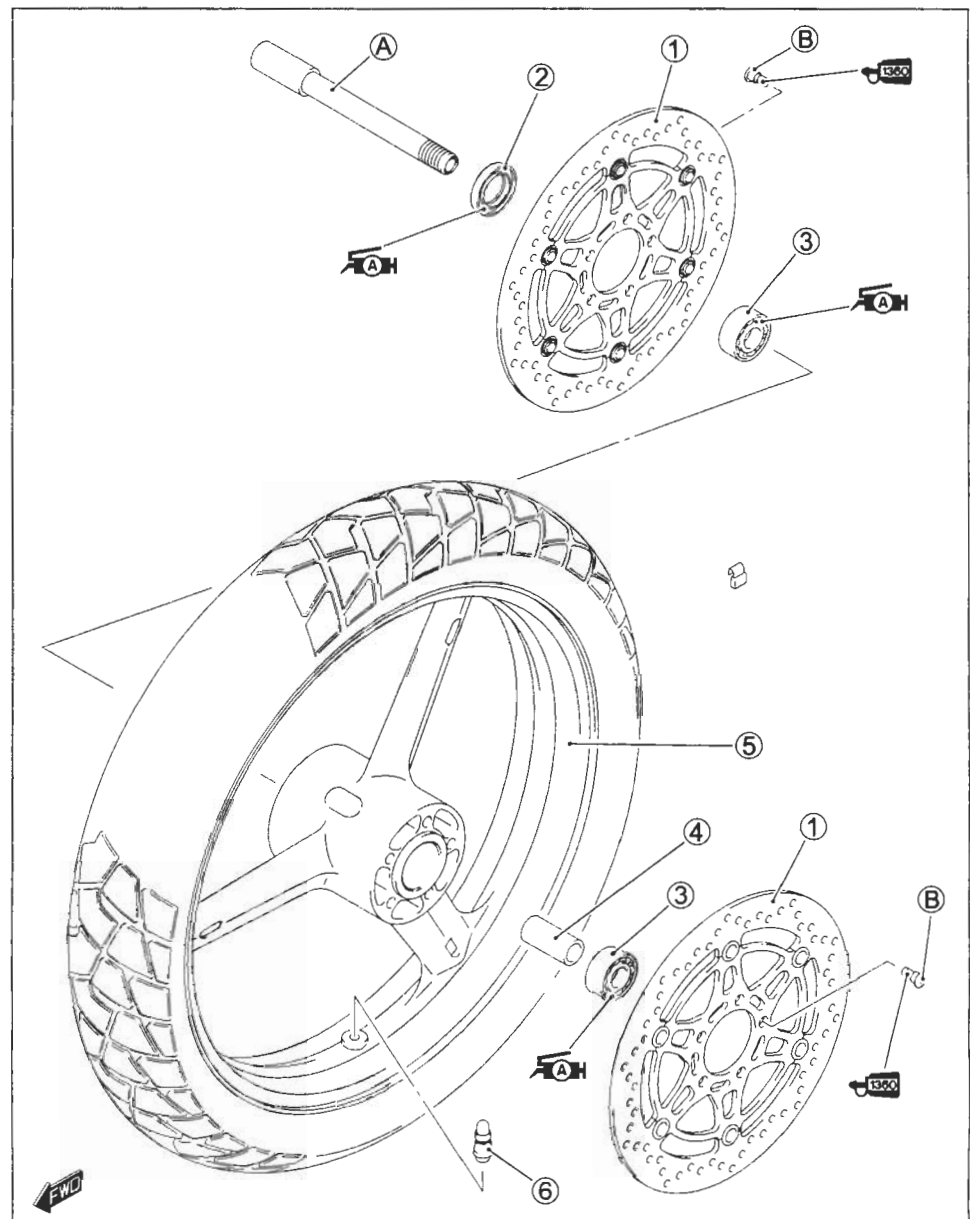

















①	Brake disc
②	Dust seal
③	Bearing
④	Center spacer
⑤	Front wheel
⑥	Tire valve
A	Front axle
B	Brake disc bolt

ITEM	N-m	kgf-m	lb-ft
A	65	6.5	47.0
B	23	2.3	16.5



## SYMBOL

Listed in the table below are the symbols indicating instructions and other information necessary for servicing. The meaning of each symbol is also included in the table.

SYMBOL	DEFINITION	SYMBOL	DEFINITION
	Torque control required. Data beside it indicates specified torque.		Apply THREAD LOCK SUPER "1360". 99000-32130
	Apply oil. Use engine oil unless otherwise specified.		Use engine coolant.
	Apply molybdenum oil solution. (Mixture of engine oil and SUZUKI MOLY PASTE in a ratio of 1:1)		Use fork oil. 99000-99001-SS8
	Apply SUZUKI SUPER GREASE "A". 99000-25030 (USA) 99000-25010 (Others)		Apply or use brake fluid.
	Apply SUZUKI MOLY PASTE. 99000-25140		Measure in voltage range.
	Apply SUZUKI SILICONE GREASE. 99000-25100		Measure in current range.
	Apply SUZUKI BOND "1215". 99000-31110 (Except USA)		Measure in resistance range.
	Apply SUZUKI BOND "1207B". 99104-31140 (USA) 99000-31140 (Others)		Measure in diode test range.
	Apply THREAD LOCK SUPER "1303". 99000-32030		Measure in continuity test range.
	Apply THREAD LOCK SUPER "1322". 99000-32110 (Except USA)		Use special tool.
	Apply THREAD LOCK "1342". 99000-32050		Indication of service data.

# ABBREVIATIONS USED IN THIS MANUAL

## A

ABDC	: After Bottom Dead Center
AC	: Alternating Current
ACL	: Air Cleaner, Air Cleaner Box
API	: American Petroleum Institute
ATDC	: After Top Dead Center
ATM Pressure:	Atmospheric Pressure
	Atmospheric Pressure Sensor (APS)
A/F	: Air Fuel Mixture

## B

BBDC	: Before Bottom Dead Center
BTDC	: Before Top Dead Center
B+	: Battery Positive Voltage

## C

CKP Sensor	: Crankshaft Position Sensor (CKPS)
CKT	: Circuit
CLP Switch	: Clutch Lever Position Switch (Clutch Switch)
CMP Sensor	: Camshaft Position Sensor (CMPS)
CO	: Carbon Monoxide
CPU	: Central Processing Unit

## D

DC	: Direct Current
DMC	: Dealer Mode Coupler
DOHC	: Double Over Head Camshaft
DRL	: Daytime Running Light

## E

ECM	: Engine Control Module
	Engine Control Unit (ECU) (FI Control Unit)
ECT Sensor	: Engine Coolant Temperature Sensor (ECTS), Water Temp. Sensor (WTS)
EVAP	: Evaporative Emission
EVAP Canister:	Evaporative Emission Canister (Canister)

## F

FI	: Fuel Injection, Fuel Injector
FP	: Fuel Pump
FPR	: Fuel Pressure Regulator
FP Relay	: Fuel Pump Relay

## G

GEN	: Generator
GND	: Ground
GP Switch	: Gear Position Switch

## H

HC	: Hydrocarbons
----	----------------

## I

IAP Sensor	: Intake Air Pressure Sensor (IAPS)
IAT Sensor	: Intake Air Temperature Sensor (IATS)
IG	: Ignition

## L

LCD	: Liquid Crystal Display
LED	: Light Emitting Diode (Malfunction Indicator Lamp)
LH	: Left Hand

## **M**

MAL-Code : Malfunction Code  
(Diagnostic Code)  
Max : Maximum  
MIL : Malfunction Indicator Lamp  
(LED)  
Min : Minimum

## **N**

NOx : Nitrogen Oxides

## **O**

OHC : Over Head Camshaft  
OPS : Oil Pressure Switch

## **P**

PCV : Positive Crankcase  
Ventilation (Crankcase Breather)

## **R**

RH : Right Hand  
ROM : Read Only Memory

## **S**

SAE : Society of Automotive Engineers  
STC System : Secondary Throttle Control  
System (STCS)  
STP Sensor : Secondary Throttle Position  
Sensor (STPS)  
ST Valve : Secondary Throttle Valve (STV)  
STV Actuator : Secondary Throttle Valve Actuator  
(STVA)

## **T**

TO Sensor : Tip Over Sensor (TOS)  
TP Sensor : Throttle Position Sensor (TPS)

## **V**

VD : Vacuum Damper

## SAE-TO-FORMER SUZUKI TERM

This table lists SAE (Society of Automotive Engineers) J1930 terms and abbreviations which may be used in this manual in compliance with SAE recommendations, as well as their former SUZUKI names.

SAE TERM		FORMER SUZUKI TERM
FULL TERM	ABBREVIATION	
<b>A</b>		
Air Cleaner	ACL	Air Cleaner, Air Cleaner Box
<b>B</b>		
Barometric Pressure	BARO	Barometric Pressure, Atmospheric Pressure (APS, AP Sensor)
Battery Positive Voltage	B+	Battery Voltage, +B
<b>C</b>		
Camshaft Position Sensor	CMP Sensor	Camshaft Position Sensor (CMPS)
Crankshaft Position Sensor	CKP Sensor	Crankshaft Position Sensor (CKPS), Crank Angle
<b>D</b>		
Data Link Connector	DLC	Dealer Mode Coupler
Diagnostic Test Mode	DTM	—
Diagnostic Trouble Code	DTC	Diagnostic Code, Malfunction Code
<b>E</b>		
Electronic Ignition	EI	—
Engine Control Module	ECM	Engine Control Module (ECM) FI Control Unit, Engine Control Unit (ECU)
Engine Coolant Level	ECL	Coolant Level
Engine Coolant Temperature	ECT	Coolant Temperature, Engine Coolant Temperature Water Temperature
Engine Speed	RPM	Engine Speed (RPM)
Evaporative Emission	EVAP	Evaporative Emission
Evaporative Emission Canister	EVAP Canister	— (Canister)
<b>F</b>		
Fan Control	FC	—
Fuel Level Sensor	—	Fuel Level Sensor, Fuel Level Gauge
Fuel Pump	FP	Fuel Pump (FP)
<b>G</b>		
Generator	GEN	Generator
Ground	GND	Ground (GND, GRD)

SAE TERM		FORMER SUZUKI TERM
FULL TERM	ABBREVIATION	
I		
Idle Speed Control	ISC	—
Ignition Control	IC	Electronic Spark Advance (ESA)
Ignition Control Module	ICM	—
Intake Air Temperature	IAT	Intake Air Temperature (IAT), Air Temperature
M		
Malfunction Indicator Lamp	MIL	LED Lamp Malfunction Indicator Lamp (MIL)
Manifold Absolute Pressure	MAP	Intake Air Pressure (IAP), Intake Vacuum
Mass Air Flow	MAF	Air Flow
O		
On-Board Diagnostic	OBD	Self-Diagnosis Function Diagnostic
Open Loop	OL	—
P		
Programmable Read Only Memory	PROM	—
Pulsed Secondary Air Injection	PAIR	Pulse Air Control (PAIR)
Purge Valve	Purge Valve	Purge Valve (SP Valve)
R		
Random Access Memory	RAM	—
Read Only Memory	ROM	ROM
S		
Secondary Air Injection	AIR	—
Secondary Throttle Control System	STCS	STC System (STCS)
Secondary Throttle Valve	STV	ST Valve (STV)
Secondary Throttle Valve Actuator	STVA	STV Actuator (STVA)
T		
Throttle Body	TB	Throttle Body (TB)
Throttle Body Fuel Injection	TBI	Throttle Body Fuel Injection (TBI)
Throttle Position Sensor	TP Sensor	TP Sensor (TPS)
V		
Voltage Regulator	VR	Voltage Regulator
Volume Air Flow	VAF	Air Flow



## WIRE COLOR

B	: Black	Gr	: Gray	R	: Red
Bl	: Blue	Lbl	: Light blue	W	: White
Br	: Brown	Lg	: Light green	Y	: Yellow
Dg	: Dark green	O	: Orange		
G	: Green	P	: Pink		

B/Bl	: Black with Blue tracer	B/Br	: Black with Brown tracer
B/G	: Black with Green tracer	B/O	: Black with Orange tracer
B/R	: Black with Red tracer	B/W	: Black with White tracer
B/Y	: Black with Yellow tracer	Bl/B	: Blue with Black tracer
Bl/G	: Blue with Green tracer	Bl/R	: Blue with Red tracer
Bl/W	: Blue with White tracer	Bl/Y	: Blue with Yellow tracer
Br/B	: Brown with Black tracer	Br/W	: Brown with White tracer
G/B	: Green with Black tracer	G/Y	: Green with Yellow tracer
Gr/B	: Gray with Black tracer	Gr/R	: Gray with Red tracer
Gr/W	: Gray with White tracer	O/B	: Orange with Black tracer
O/Bl	: Orange with Blue tracer	O/G	: Orange with Green tracer
O/R	: Orange with Red tracer	O/W	: Orange with White tracer
O/Y	: Orange with Yellow tracer	P/W	: Pink with White tracer
R/B	: Red with Black tracer	R/W	: Red with White tracer
W/B	: White with Black tracer	W/Bl	: White with Blue tracer
W/G	: White with Green tracer	W/R	: White with Red tracer
Y/B	: Yellow with Black tracer	Y/Bl	: Yellow with Blue tracer
Y/G	: Yellow with Green tracer	Y/R	: Yellow with Red tracer
Y/W	: Yellow with White tracer		

# GENERAL INFORMATION

1

## CONTENTS

<b>WARNING/CAUTION/NOTE .....</b>	<b>1- 2</b>
<b>GENERAL PRECAUTIONS.....</b>	<b>1- 2</b>
<b>SUZUKI DL650K4 ('04-MODEL).....</b>	<b>1- 4</b>
<b>SERIAL NUMBER LOCATION.....</b>	<b>1- 4</b>
<b>FUEL, OIL AND ENGINE COOLANT RECOMMENDATION.....</b>	<b>1- 4</b>
<b>FUEL (FOR USA AND CANADA).....</b>	<b>1- 4</b>
<b>FUEL (FOR OTHER COUNTRIES).....</b>	<b>1- 4</b>
<b>ENGINE OIL (FOR USA).....</b>	<b>1- 5</b>
<b>ENGINE OIL (FOR OTHER COUNTRIES) .....</b>	<b>1- 5</b>
<b>BRAKE FLUID.....</b>	<b>1- 5</b>
<b>FRONT FORK OIL .....</b>	<b>1- 5</b>
<b>ENGINE COOLANT .....</b>	<b>1- 5</b>
<b>WATER FOR MIXING .....</b>	<b>1- 5</b>
<b>ANTI-FREEZE/ENGINE COOLANT.....</b>	<b>1- 6</b>
<b>LIQUID AMOUNT OF WATER/ENGINE COOLANT .....</b>	<b>1- 6</b>
<b>BREAK-IN PROCEDURES .....</b>	<b>1- 6</b>
<b>CYLINDER IDENTIFICATION .....</b>	<b>1- 7</b>
<b>INFORMATION LABELS.....</b>	<b>1- 8</b>
<b>SPECIFICATIONS .....</b>	<b>1- 9</b>
<b>DIMENSIONS AND DRY MASS .....</b>	<b>1- 9</b>
<b>ENGINE .....</b>	<b>1- 9</b>
<b>DRIVE TRAIN.....</b>	<b>1- 9</b>
<b>CHASSIS.....</b>	<b>1-10</b>
<b>ELECTRICAL .....</b>	<b>1-10</b>
<b>CAPACITIES .....</b>	<b>1-10</b>
<b>COUNTRY AND AREA CODES.....</b>	<b>1-11</b>

## WARNING/CAUTION/NOTE

Please read this manual and follow its instructions carefully. To emphasize special information, the symbol and the words WARNING, CAUTION and NOTE have special meanings. Pay special attention to the messages highlighted by these signal words.

### **▲ WARNING**

Indicates a potential hazard that could result in death or injury.

### **CAUTION**

Indicates a potential hazard that could result in motorcycle damage.

### *NOTE:*

*Indicates special information to make maintenance easier or instructions clearer.*

Please note, however, that the warnings and cautions contained in this manual cannot possibly cover all potential hazards relating to the servicing, or lack of servicing, of the motorcycle. In addition to the WARNINGS and CAUTIONS stated, you must use good judgement and basic mechanical safety principles. If you are unsure about how to perform a particular service operation, ask a more experienced mechanic for advice.

## GENERAL PRECAUTIONS

### **▲ WARNING**

- \* Proper service and repair procedures are important for the safety of the service mechanic and the safety and reliability of the motorcycle.
- \* When 2 or more persons work together, pay attention to the safety of each other.
- \* When it is necessary to run the engine indoors, make sure that exhaust gas is forced outdoors.
- \* When working with toxic or flammable materials, make sure that the area you work in is well-ventilated and that you follow all of the material manufacturer's instructions.
- \* Never use gasoline as a cleaning solvent.
- \* To avoid getting burned, do not touch the engine, engine oil, radiator and exhaust system until they have cooled.
- \* After servicing the fuel, oil, water, exhaust or brake systems, check all lines and fittings related to the system for leaks.

**CAUTION**

- \* If parts replacement is necessary, replace the parts with Suzuki Genuine Parts or their equivalent.
- \* When removing parts that are to be reused, keep them arranged in an orderly manner so that they may be reinstalled in the proper order and orientation.
- \* Be sure to use special tools when instructed.
- \* Make sure that all parts used in reassembly are clean. Lubricate them when specified.
- \* Use the specified lubricant, bond, or sealant.
- \* When removing the battery, disconnect the negative cable first and then the positive cable.
- \* When reconnecting the battery, connect the positive cable first and then the negative cable, and replace the terminal cover on the positive terminal.
- \* When performing service to electrical parts, if the service procedures not require use of battery power, disconnect the negative cable the battery.
- \* When tightening the cylinder head and case bolts and nuts, tighten the larger sizes first. Always tighten the bolts and nuts diagonally from the inside toward outside and to the specified tightening torque.
- \* Whenever you remove oil seals, gaskets, packing, O-rings, locking washers, self-locking nuts, cotter pins, circlips and certain other parts as specified, be sure to replace them with new ones. Also, before installing these new parts, be sure to remove any left over material from the mating surfaces.
- \* Never reuse a circlip. When installing a new circlip, take care not to expand the end gap larger than required to slip the circlip over the shaft. After installing a circlip, always ensure that it is completely seated in its groove and securely fitted.
- \* Use a torque wrench to tighten fasteners to the specified torque. Wipe off grease and oil if a thread is smeared with them.
- \* After reassembling, check parts for tightness and proper operation.

- \* To protect the environment, do not unlawfully dispose of used motor oil, engine coolant and other fluids: batteries, and tires.
- \* To protect Earth's natural resources, properly dispose of used motorcycle and parts.

## SUZUKI DL650K4 ('04-MODEL)



RIGHT SIDE



LEFT SIDE

- Difference between photographs and actual motorcycles depends on the markets.

## SERIAL NUMBER LOCATION

The frame serial number or V.I.N. (Vehicle Identification Number) ① is stamped on the right side of the steering head. The engine serial number ② is located on the left side of the crankcase. These numbers are required especially for registering the machine and ordering spare parts.

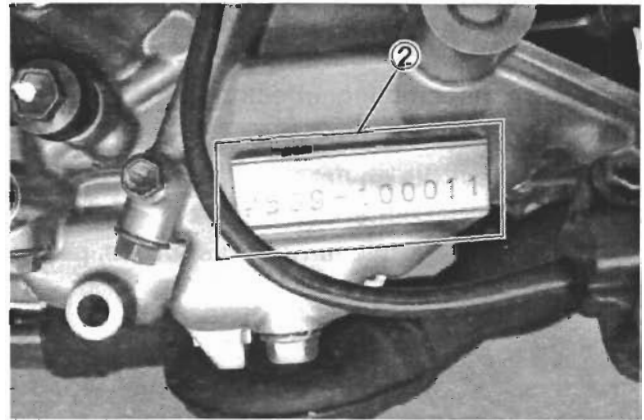
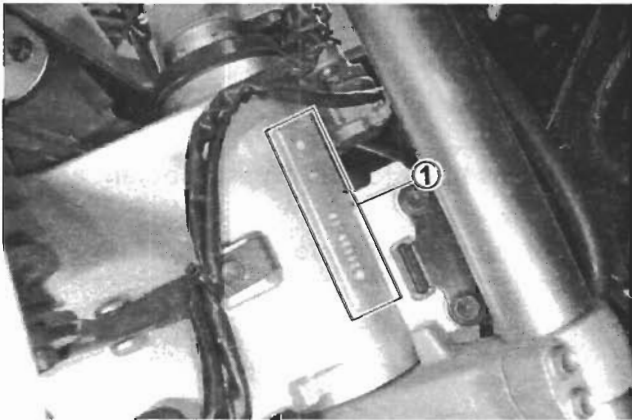

## FUEL, OIL AND ENGINE COOLANT RECOMMENDATION

### FUEL (FOR USA AND CANADA)

Use only unleaded gasoline of at least 87 pump octane (  $\frac{R+M}{2}$  ) or 91 octane or higher rated by the research method.

Gasoline containing MTBE (Methyl Tertiary Butyl Ether), less than 10 % ethanol, or less than 5 % methanol with appropriate cosolvents and corrosion inhibitor is permissible.

### FUEL (FOR OTHER COUNTRIES)

Gasoline used should be graded 91 octane (Research Method) or higher. Unleaded gasoline is recommended.

## ENGINE OIL (FOR USA)

SUZUKI recommends the use of SUZUKI PERFORMANCE 4 MOTOR OIL or an oil which is rated SF or SG under the API (American Petroleum Institute) service classification. The recommended viscosity is SAE 10W-40. If an SAE 10W-40 oil is not available, select an alternative according to the following chart.

## ENGINE OIL (FOR OTHER COUNTRIES)

Use a premium quality 4-stroke motor oil to ensure longer service life of your motorcycle. Use only oils which are rated SF or SG under the API service classification. The recommended viscosity is SAE 10W-40. If an SAE 10W-40 motor oil is not available, select an alternative according to the right chart.

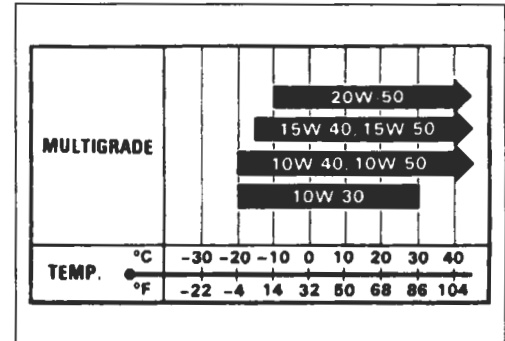

## BRAKE FLUID

Specification and classification: DOT 4

### ⚠ WARNING

Since the brake system of this motorcycle is filled with a glycol-based brake fluid by the manufacturer, do not use or mix different types of fluid such as silicone-based and petroleum-based fluid for refilling the system, otherwise serious damage will result.

Do not use any brake fluid taken from old or used or unsealed containers.

Never re-use brake fluid left over from a previous servicing, which has been stored for a long period.

## FRONT FORK OIL

Use fork oil SS8 or an equivalent fork oil.

## ENGINE COOLANT

Use an anti-freeze/engine coolant compatible with an aluminum radiator, mixed with distilled water only.

## WATER FOR MIXING

Use distilled water only. Water other than distilled water can corrode and clog the aluminum radiator.

## ANTI-FREEZE/ENGINE COOLANT

The engine coolant perform as a corrosion and rust inhibitor as well as anti-freeze. Therefore, the engine coolant should be used at all times even though the atmospheric temperature in your area does not go down to freezing point.

Suzuki recommends the use of SUZUKI COOLANT anti-freeze/engine coolant. If this is not available, use an equivalent which is compatible with an aluminum radiator.

## LIQUID AMOUNT OF WATER/ENGINE COOLANT

**Solution capacity (total): 1 900 ml (4.01/3.34 US/Imp qt)**

For engine coolant mixture information, refer to cooling system section, page 6-2

### CAUTION

**Mixing of anti-freeze/engine coolant should be limited to 60 %. Mixing beyond it would reduce its efficiency. If the anti-freeze/engine coolant mixing ratio is below 50 %, rust inhabiting performance is greatly reduced. Be sure to mix it above 50 % even though the atmospheric temperature does not go down to the freezing point.**

## BREAK-IN PROCEDURES

During manufacture only the best possible materials are used and all machined parts are finished to a very high standard but it is still necessary to allow the moving parts to "BREAK-IN" before subjecting the engine to maximum stresses. The future performance and reliability of the engine depends on the care and restraint exercised during its early life. The general rules are as follows.

- Keep to these break-in engine speed limits:

**Initial 800 km ( 500 miles): Below 5 000 r/min**

**Up to 1 600 km (1 000 miles): Below 7 500 r/min**

**Over to 1 600 km (1 000 miles): Below 10 500 r/min**

- Upon reaching an odometer reading of 1 600 km (1 000 miles) you can subject the motorcycle to full throttle operation. However, do not exceed 10 500 r/min at any time.

## CYLINDER IDENTIFICATION

The two cylinders of this engine are identified as NO.1 and NO.2 cylinder, as viewed from front to rear .

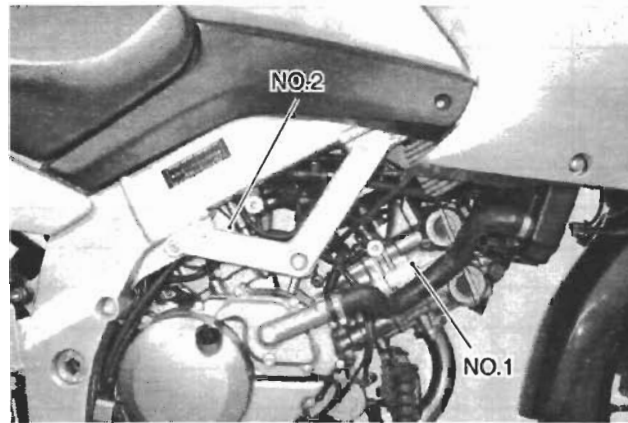



# INFORMATION LABELS

	DL650	DL650UE
① Noise label	A (For E-03, 24, 33)	
② Information label	A (For E-03, 28, 33)	
③ Vacuum hose routing label	A (For E-33)	
④ Fuel caution label	A (For E-02, 24)	
⑤ Manual notice label	A (For E-03, 33)	
⑥ Frame caution plate	A	A
⑦ Screen warning label	A	A
⑧ Steering warning label	A	A
⑨ Tire information label	A	A
⑩ Warning safety label	A	A
⑪ ICES Canada label	A (For E-28)	
⑫ ID plate	A (Except for E-03, 28, 33)	A
⑬ Safety plate	A (For E-03, 28, 33)	
⑭ Rear carrier warning label	A	A (For English)

A: Attached

\*1: For E-28 (French) \*2: Except for E-28 \*3: For E-28 \*4: These labels are attached on the right frame.

\*5: This label is attached on the up side of chain cover.

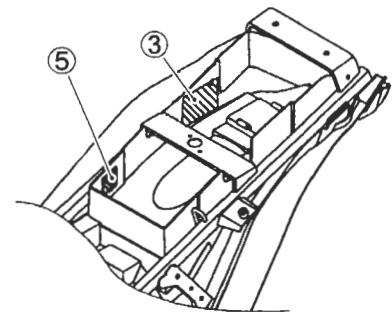
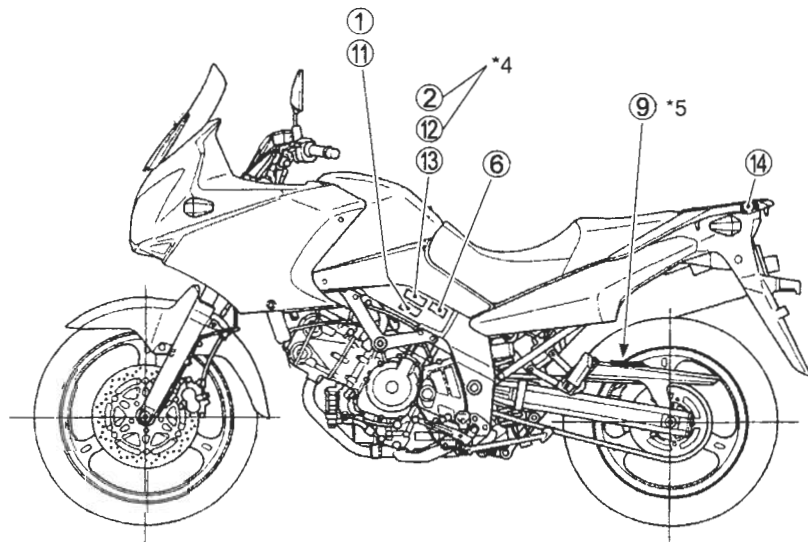
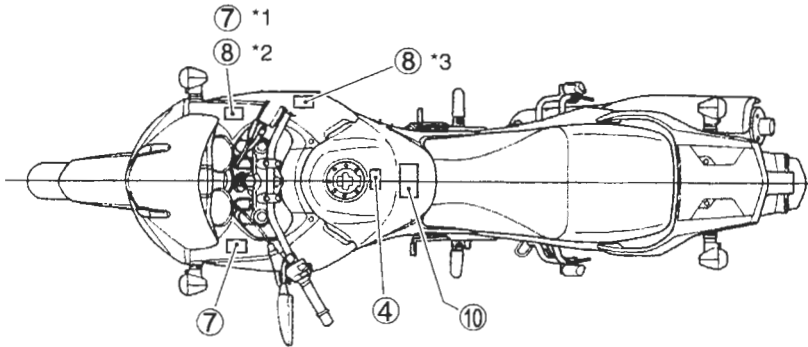

## SPECIFICATIONS

### DIMENSIONS AND DRY MASS

Overall length .....	2 290 mm (90.2 in)
Overall width .....	840 mm (33.1 in)
Overall height .....	1 390 mm (54.7 in) ..... Low windshield position (STD) 1 420 mm (55.9 in) ..... Middle windshield position 1 450 mm (57.1 in) ..... High windshield position
Wheelbase .....	1 540 mm (60.6 in)
Ground clearance.....	165 mm ( 6.5 in)
Seat height .....	820 mm (32.3 in)
Dry mass .....	190 kg (418 lbs)

### ENGINE

Type .....	4-stroke, liquid-cooled, DOHC, 90 °-degree V-twin
Number of cylinders .....	2
Bore.....	81.0 mm (3.189 in)
Stroke.....	62.6 mm (2.465 in)
Displacement .....	645 cm <sup>3</sup> (39.4 cu.in)
Compression ratio .....	11.5 : 1
Carburetion .....	Fuel injection
Air cleaner .....	Non-woven fabric element
Starter system .....	Electric
Lubrication system .....	Wet sump
Idle speed.....	1 300 ± 100 r/min

### DRIVE TRAIN

Clutch .....	Wet multi-plate type
Transmission.....	6-speed constant mesh
Gearshift pattern .....	1-down, 5-up
Primary reduction ratio .....	2.088 (71/34)
Final reduction ratio.....	3.133 (47/15)
Gear ratios, Low .....	2.461 (32/13)
2nd.....	1.777 (32/18)
3rd.....	1.380 (29/21)
4th.....	1.125 (27/24)
5th.....	0.961 (25/26)
Top.....	0.851 (23/27)
Drive chain .....	DID 525 V8, 116 links

**CHASSIS**

Front suspension .....	Telescopic, coil spring, oil damped
Rear suspension .....	Link type, coil spring, oil damped
Front fork stroke .....	150 mm (5.9 in)
Rear wheel travel .....	150 mm (5.9 in)
Caster .....	26 °
Trail .....	110 mm (4.33 in)
Steering angle .....	40 ° (right & left)
Turning radius .....	2.6 m (8.5 ft)
Front brake .....	Disc brake, twin
Rear brake .....	Disc brake
Front tire size .....	110/80 R19 M/C 59H, tubeless
Rear tire size .....	150/70 R17 M/C 69H, tubeless

**ELECTRICAL**

Ignition type .....	Electronic ignition (Transistorized)
Ignition timing .....	4 ° B.T.D.C. at 1 300 r/min
Spark plug .....	NGK CR8E, or DENSO U24ESR-N
Battery .....	12V 36.0 kC (10 Ah)/10 HR
Generator .....	Three-phase A.C. generator
Main fuse .....	30 A
Fuse .....	15/15/10/10/15/15 A
Headlight .....	12 V 60/55 W × 2 (H4)
Position/Parking light .....	12 V 5 W × 2 ..... Except E-03, 24, 33
Brake light/Taillight .....	12 V 21/5 W × 2
License plate light .....	12 V 5 W
Turn signal light .....	12 V 21 W
Speedometer light .....	LED
Turn signal indicator light .....	LED
Neutral indicator light .....	LED
High beam indicator light .....	LED
Oil pressure/Coolant temperature/ Fuel injection warning light .....	LED

**CAPACITIES**

Fuel tank, including reserve .....	22 L (5.8/4.8 US/Imp gal)
Engine oil, oil change .....	2 300 ml (2.4/2.0 US/Imp qt)
with filter change .....	2 700 ml (2.9/2.4 US/Imp qt)
overhaul .....	3 100 ml (3.3/2.7 US/Imp qt)
Coolant .....	1.9 L (2.0/1.7 US/Imp qt)

These specifications are subject to change without notice.

## COUNTRY AND AREA CODES

The following codes stand for the applicable country (-ies) and area (-s).

MODEL	CODE	COUNTRY or AREA
DL650	E-02	U.K.
	E-03	U.S.A. (Except for california)
	E-19	EU
	E-24	Australia
	E-28	Canada
	E-33	California (U.S.A.)
DL650-UE	E-19	EU

# PERIODIC MAINTENANCE

## CONTENTS

<b>PERIODIC MAINTENANCE SCHEDULE .....</b>	<b>2- 2</b>
<b>PERIODIC MAINTENANCE CHART .....</b>	<b>2- 2</b>
<b>LUBRICATION POINTS .....</b>	<b>2- 4</b>
<b>MAINTENANCE AND TUNE-UP PROCEDURES .....</b>	<b>2- 5</b>
<b>AIR CLEANER .....</b>	<b>2- 5</b>
<b>SPARK PLUG .....</b>	<b>2- 6</b>
<b>VALVE CLEARANCE .....</b>	<b>2- 8</b>
<b>FUEL LINE .....</b>	<b>2-13</b>
<b>ENGINE OIL AND OIL FILTER .....</b>	<b>2-13</b>
<b>ENGINE IDLE SPEED .....</b>	<b>2-15</b>
<b>THROTTLE CABLE PLAY .....</b>	<b>2-15</b>
<b>THROTTLE VALVE SYNCHRONIZATION .....</b>	<b>2-16</b>
<b>EVAPORATIVE EMISSION CONTROL SYSTEM (E-33 ONLY) .....</b>	<b>2-16</b>
<b>PAIR (AIR SUPPLY) SYSTEM .....</b>	<b>2-16</b>
<b>CLUTCH .....</b>	<b>2-17</b>
<b>COOLING SYSTEM .....</b>	<b>2-18</b>
<b>DRIVE CHAIN .....</b>	<b>2-20</b>
<b>BRAKE .....</b>	<b>2-22</b>
<b>TIRE .....</b>	<b>2-26</b>
<b>STEERING .....</b>	<b>2-26</b>
<b>FRONT FORK .....</b>	<b>2-27</b>
<b>REAR SUSPENSION .....</b>	<b>2-27</b>
<b>EXHAUST PIPE BOLT .....</b>	<b>2-27</b>
<b>CHASSIS BOLT AND NUT .....</b>	<b>2-28</b>
<b>COMPRESSION PRESSURE CHECK .....</b>	<b>2-30</b>
<b>COMPRESSION TEST PROCEDURE .....</b>	<b>2-30</b>
<b>OIL PRESSURE CHECK .....</b>	<b>2-31</b>

## PERIODIC MAINTENANCE SCHEDULE

The chart below lists the recommended intervals for all the required periodic service work necessary to keep the motorcycle operating at peak performance and economy. Mileages are expressed in terms of kilometers, miles and time for your convenience.

**IMPORTANT:** The periodic maintenance intervals and service requirements have been established in accordance with EPA regulations. Following these instructions will ensure that the motorcycle will not exceed emission standards and it will also ensure the reliability and performance of the motorcycle.

**NOTE:**

*More frequent servicing may be performed on motorcycles that are used under severe conditions.*

### PERIODIC MAINTENANCE CHART

Item	Interval	1 000	6 000	12 000	18 000	24 000	
	km						
	miles	600	4 000	7 500	11 000	14 500	
		months	2	12	24	36	48
Air cleaner element		—			R		
Exhaust pipe bolts and muffler bolts		T	T	T	T	T	
Valve clearance		—	—	—	—		
Spark plugs		—		R		R	
Fuel line		—					
Replace every 4 years.							
Engine oil		R	R	R	R	R	
Engine oil filter		R	—	—	R	—	
Idle speed							
Throttle cable play							
Throttle valve synchronization			—		—		
	(E-33 only)						
Evaporative emission control system (E-33 only)		—	—		—		
Replace vapor hose every 4 years.							
PAIR (air supply) system		—	—		—		
Engine coolant		Replace every 2 years.					
Radiator hoses		—					
Replace every 4 years.							
Clutch		—					
Drive chain							
Clean and lubricate every 1 000 km (600 miles).							
Brakes							
Brake hose		—					
Replace every 4 years.							

Item	Interval	km	1 000	6 000	12 000	18 000	24 000
		miles	600	4 000	7 500	11 000	14 500
		months	2	12	24	36	48
Brake fluid		—					
		Replace every 2 years.					
Tires		—					
Steering			—		—		
Front forks		—	—		—		
Rear suspension		—	—		—		
Chassis bolts and nuts		T	T	T	T	T	T

**NOTE:**

*I=Inspect and clean, adjust, replace or lubricate as necessary;*

*R=Replace; T=Tighten*

## LUBRICATION POINTS

Proper lubrication is important for smooth operation and long life of each working part of the motorcycle. Major lubrication points are indicated below.

①	Clutch lever holder
②	Side-stand pivot and spring hook
③	Footrest pivot
④	Drive chain
⑤	Brake lever holder and throttle cables
⑥	Brake pedal pivot and footrest pivot

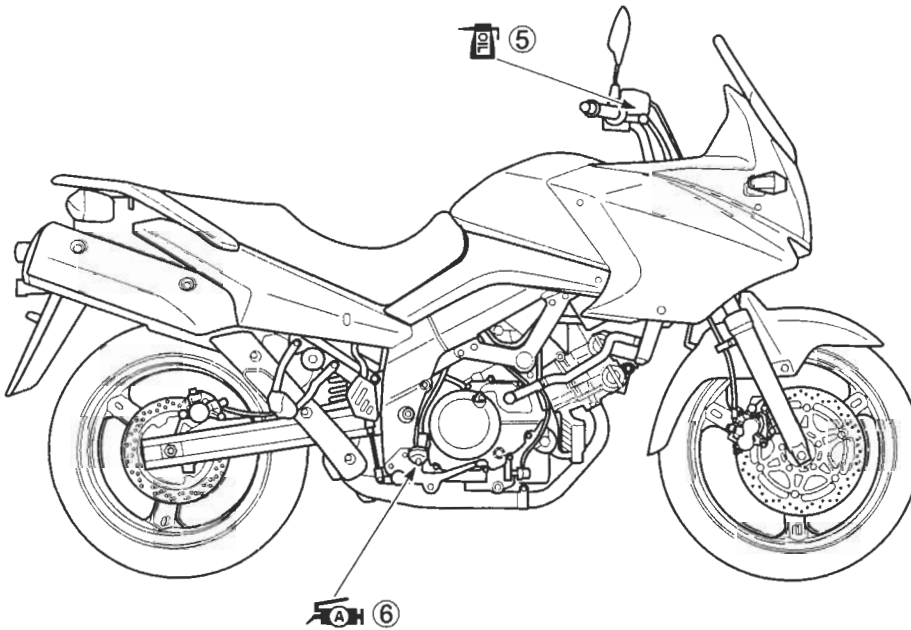
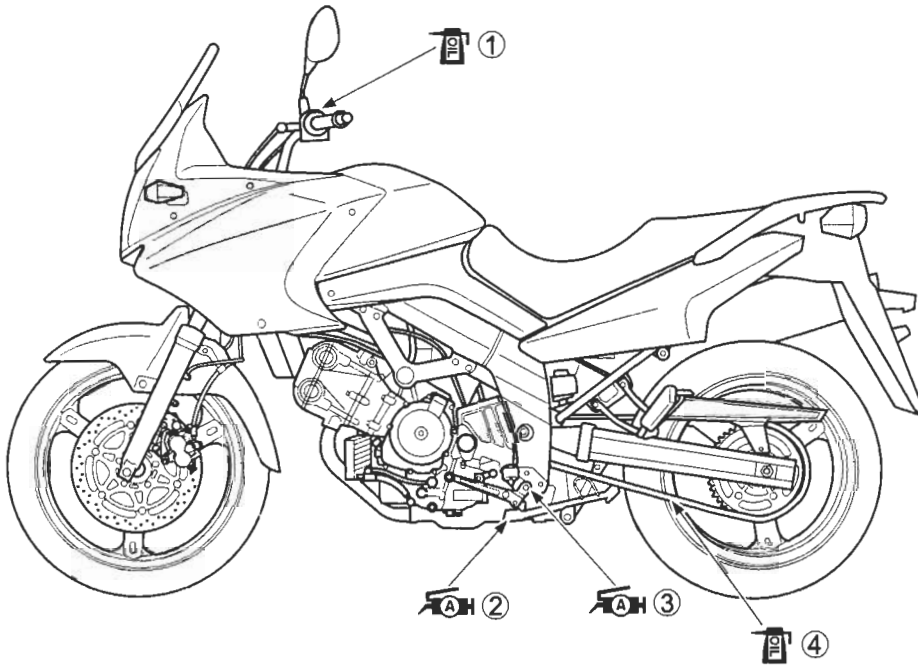

**NOTE:**

- \* Before lubricating each part, clean off any rusty spots and wipe off any grease, oil, dirt or grime.
- \* Lubricate exposed parts which are subject to rust, with a rust preventative spray whenever the motorcycle has been operated under wet or rainy conditions.



## MAINTENANCE AND TUNE-UP PROCEDURES

This section describes the servicing procedures for each item of the Periodic Maintenance requirements.

### AIR CLEANER

Inspect every 6 000 km (4 000 miles, 12 months) and replace every 18 000 km (11 000 miles, 36 months).

- Remove the seat. (☞ 7-4)
- Remove the fuel tank. (☞ 5-7)
- Remove the air cleaner box cap ①.
- Remove the air cleaner element ②.

- Carefully use air hose to blow the dust from the cleaner element.

#### CAUTION

Always use air pressure on the throttle body side of the air cleaner element. If air pressure is used on the other side, dirt will be forced into the pores of the air cleaner element thus restricting air flow through the air cleaner element.

- Install the O-ring ③ properly.
- Reinstall the cleaned or new air cleaner element in the reverse order of removal.

#### CAUTION

If driving under dusty condition, clean the air cleaner element more frequently. The surest way to accelerate engine wear is to use the engine without the element or to use a ruptured element. Make sure that the air cleaner is in good condition at all times. Life of the engine depends largely on this component!

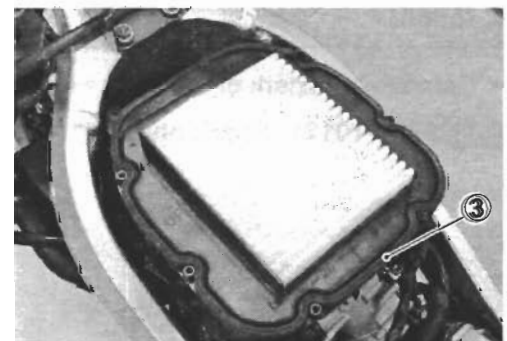
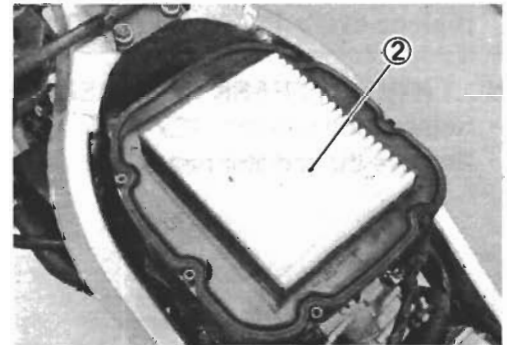
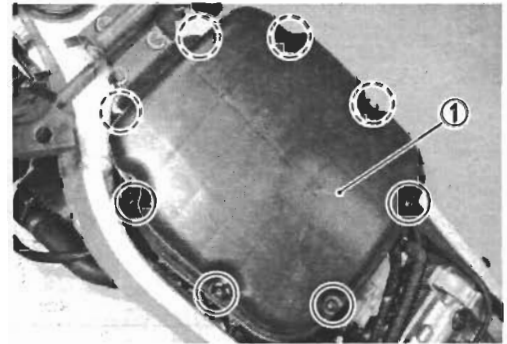

**NOTE:**

When cleaning the air cleaner element, drain water from the air cleaner by removing the drain plug.



## SPARK PLUG

Inspect every 6 000 km (4 000 miles, 12 months) and replace every 12 000 km (7 500 miles, 24 months).

### NO.1 (FRONT) SPARK PLUG REMOVAL

- Remove the cowling. (☞ 7-5).
- Remove the radiator mounting bolt ①.

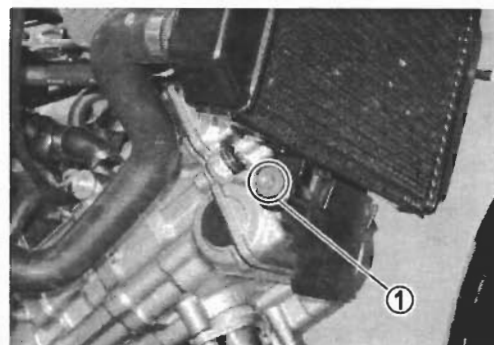

- Move the radiator lower side to forward.
- Remove the spark plug cap ②.

**NOTE:**

Be careful not to damage the radiator fins.

#### **⚠ WARNING**

The hot radiator and the hot engine can burn you. Wait until the radiator and the engine are cool enough to touch.

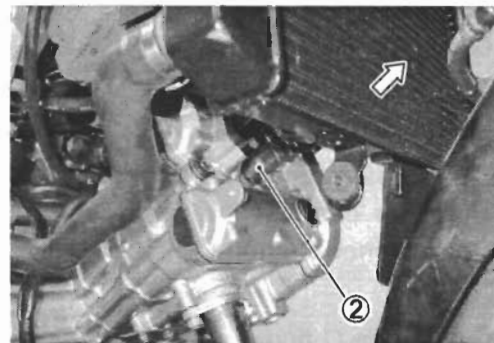

- Remove the spark plug with the special tool.

 09930-10121: Spark plug socket wrench set



**NO.2 (REAR) SPARK PLUG REMOVAL**

- Remove the seat. (☞7-4)
- Lift and support the fuel tank. (☞5-7)
- Remove the spark plug cap.
- Remove the spark plug with the special tool.

**TOOL** 09930-10121: Spark plug socket wrench set



**HEAT RANGE**

- Check to see the heat range of the plug.

	Standard	Cold type	Hot type
NGK	CR8E	CR9E	CR7E
DENSO	U24ESR-N	U27ESR-N	U22ESR-N

**CARBON DEPOSIT**

- Check to see if there are carbons deposit on the plugs. If carbon is deposited, remove it with a spark plug cleaner machine or carefully using a tool with a pointed end.

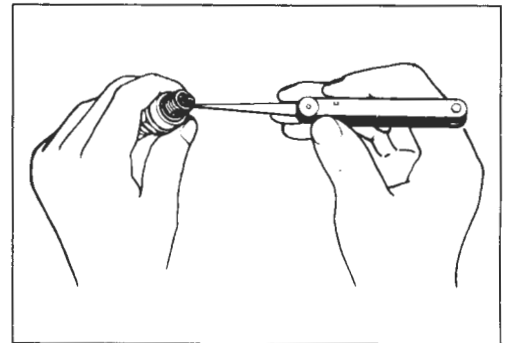

**SPARK PLUG GAP**

- Measure the plug gap with a thickness gauge. If out of specification, adjust it to the following gap.

**DATA** Spark plug gap (A)

Standard: 0.7 – 0.8 mm (0.028 – 0.031 in)

**TOOL** 09900-20803: Thickness gauge

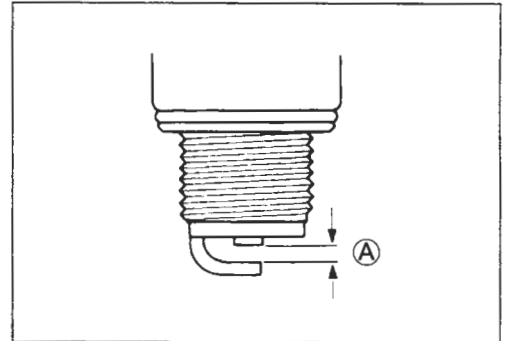

**ELECTRODES CONDITION**

- Check to see the worn or burnt condition of the electrodes. If it is extremely worn or burnt, replace the plug. And also replace the plug if it has a broken insulator, damaged thread.

**CAUTION**

Confirm the thread size and reach when replacing the plug. If the reach is too short, carbon will be deposited on the screw portion of the plug hole and engine damage may result.

## SPARK PLUG AND PLUG CAP INSTALLATION

### CAUTION

Before using a spark plug wrench, carefully turn the spark plug by finger into the threads of the cylinder head to prevent damage the aluminum threads.

- Install the spark plugs to the cylinder heads by finger tight, and then tighten them to the specified torque.

**🔧 Spark plug: 11 N·m (1.1 kgf·m, 8.0 lb-ft)**

### NOTE:

When fitting the spark plug caps, front and rear, face the triangle mark **A** on the water-proof cover to each cylinder exhaust side.

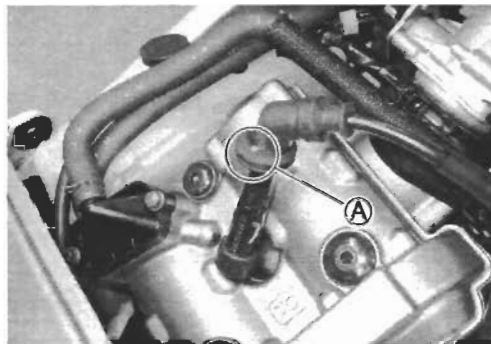

## VALVE CLEARANCE

Inspect every 24 000 km (15 000 miles, 48 months).

- Remove the seat. (☞7-4)
- Lift and support the fuel tank. (☞5-7)
- Remove the spark plugs. (☞2-6)
- Remove the cylinder head covers.

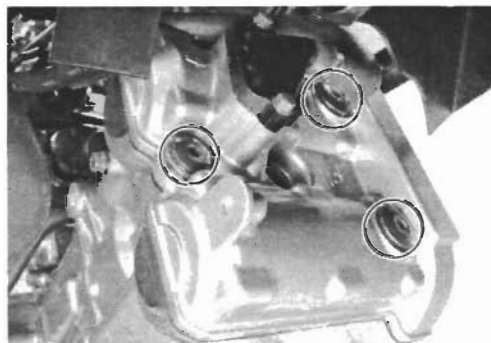

The valve clearance specification is different for intake and exhaust valves.

Valve clearance must be checked and adjusted, 1) at the time of periodic inspection, 2) when the valve mechanism is serviced, and 3) when the camshafts are disturbed by removing them for servicing.

### DATA Valve clearance (when cold)

IN. : 0.10 – 0.20 mm (0.004 – 0.008 in)

EX. : 0.20 – 0.30 mm (0.008 – 0.012 in)

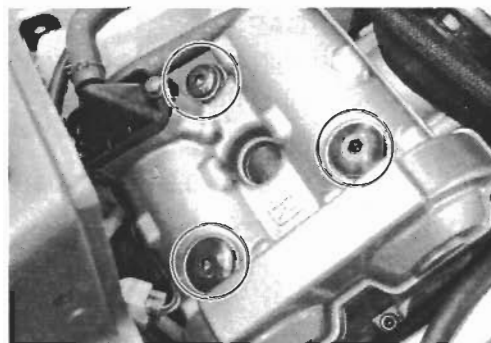

### NOTE:

- \* The valve clearance should be taken when each cylinder is at Top Dead Center (TDC) of compression stroke.
- \* The cams (IN & EX) on the front cylinder at position **A** show the front cylinder at TDC of compression stroke.
- \* The cams (IN & EX) on the rear cylinder at position **B** show the rear cylinder at TDC of compression stroke.
- \* The clearance specification is for COLD state.
- \* To turn the crankshaft for clearance checking, be sure to use a 17-mm wrench, and rotate in the normal running direction. All spark plugs should be removed.

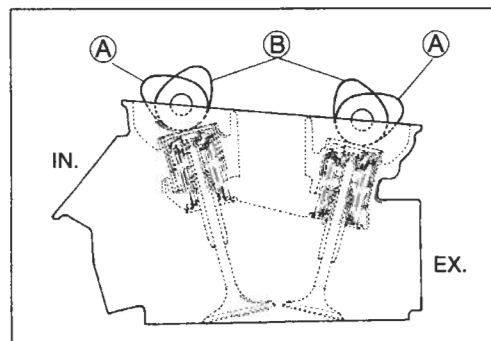

- Remove the generator cover plug ① and timing inspection plug ②.

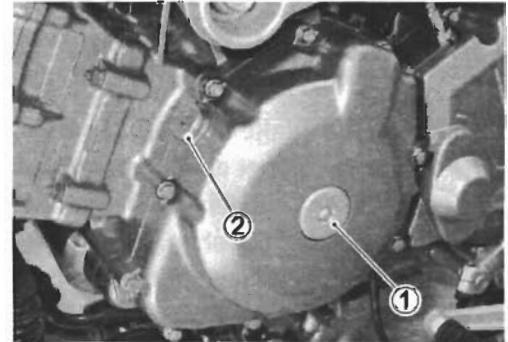

- Turn the crankshaft to set the No.1 (Front) cylinder at TDC of compression stroke. (Align the "F I T" line on the generator rotor to the index mark of valve timing inspection hole and also bring the camshafts to the position as shown in page 2-8.)

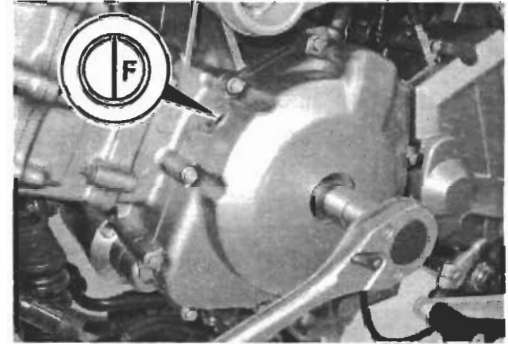

- To inspect the No.1 (Front) cylinder valve clearance, use a thickness gauge between the tappet and the cam. If the clearance is out of specification, adjust it into the specified range.

 **09900-20803: Thickness gauge**

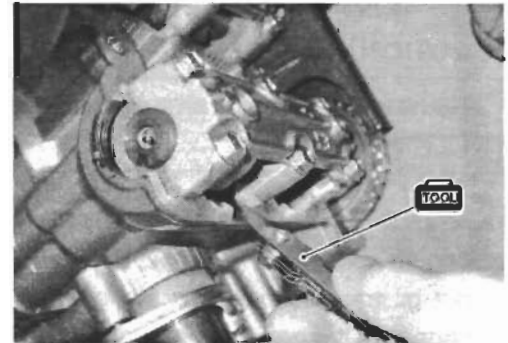

- Turn the crankshaft 270 degrees (3/4 turns) to set the No.2 (Rear) cylinder at TDC of compression stroke. (Align the "R I T" line on the generator rotor to the index mark of valve timing inspection hole and also bring the camshafts to the position as shown in page 2-8.)

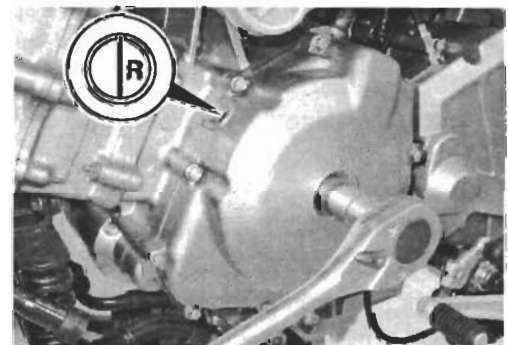

- Inspect the No.2 (Rear) cylinder valve clearance as the same manner of No.1 (Front) cylinder and adjust the clearance if necessary.

 **09900-20803: Thickness gauge**

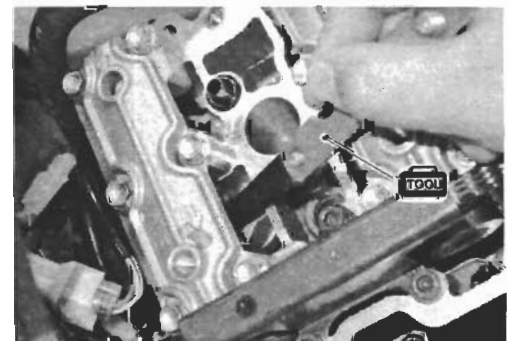

**VALVE CLEARANCE ADJUSTMENT**

The clearance is adjusted by replacing the existing tappet shim by a thicker or thinner shim.

- Remove the intake or exhaust camshafts. (☞ 3-21, 23)
- Remove the tappet and shim by fingers or magnetic hand.
- Check the figures printed on the shim. These figures indicate the thickness of the shim, as illustrated.
- Select a replacement shim that will provide a clearance within the specified range. For the purpose of this adjustment, a total of 21 sizes of tappet shim are available ranging from 1.20 to 2.20 mm in steps of 0.05 mm. Fit the selected shim to the valve stem end, with numbers toward tappet. Be sure to check shim size with micrometer to ensure its size. Refer to the tappet shim selection table (Pages 2-11 and - 12) for details.

**NOTE:**

- \* Be sure to apply engine oil to tappet shim top and bottom faces.
- \* When seating the tappet shim, be sure to face figure printed surface to the tappet.

**CAUTION**

**Reinstall the camshafts as the specified manner.**  
(☞ 3-99)

- After replacing the tappet shim and camshafts, rotate the engine so that the tappet is depressed fully. This will squeeze out oil trapped between the shim and the tappet that could cause an incorrect measurement, then check the clearance again to confirm that it is within the specified range.
- After finishing the valve clearance adjustment, reinstall the following items.
- When installing the cylinder head cover, do not forget the gasket **A**.
- Install the following items.
  - \* Cylinder head cover (☞ 3-106)
  - \* Spark plug and plug cap (☞ 2-8)
  - \* Valve timing inspection plug (☞ 3-108)
  - \* Generator cover plug (☞ 3-108)

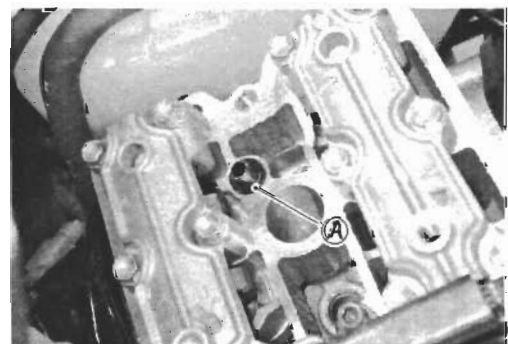
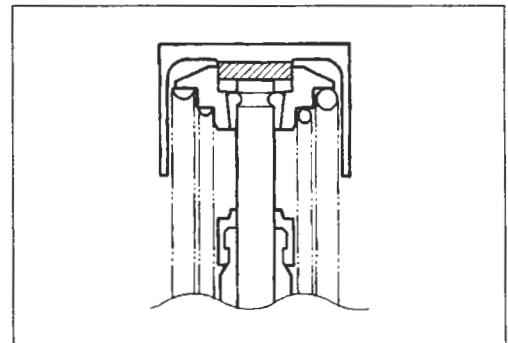
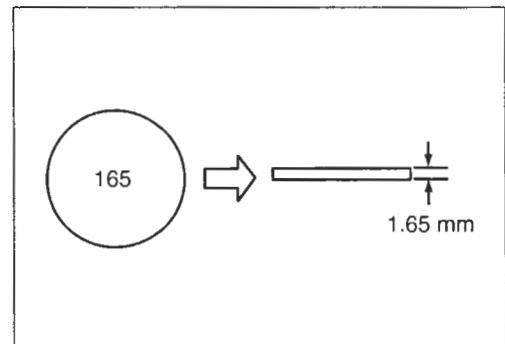
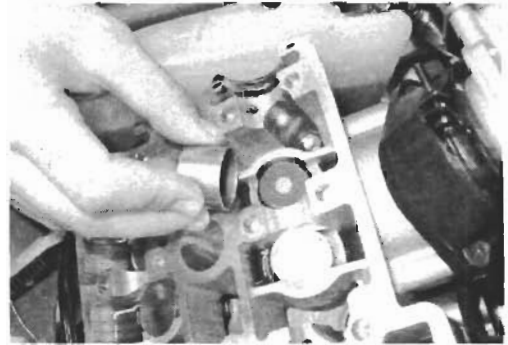

TAPPET SHIM SELECTION TABLE [INTAKE]  
TAPPET SHIM NO. (12892-05C00-XXX)

TAPPET SHIM SET (12800-05830)

(INTAKE SIDE)

MEASURED TAPPET CLEARANCE (mm)	SUFFIX NO.	120	125	130	135	140	145	150	155	160	165	170	175	180	185	190	195	200	205	210	215	220
	PRESENT SHIM SIZE (mm)	1.20	1.25	1.30	1.35	1.40	1.45	1.50	1.55	1.60	1.65	1.70	1.75	1.80	1.85	1.90	1.95	2.00	2.05	2.10	2.15	2.20
0.00-0.04				1.20	1.25	1.30	1.35	1.40	1.45	1.50	1.55	1.60	1.65	1.70	1.75	1.80	1.85	1.90	1.95	2.00	2.05	2.10
0.05-0.09			1.20	1.25	1.30	1.35	1.40	1.45	1.50	1.55	1.60	1.65	1.70	1.75	1.80	1.85	1.90	1.95	2.00	2.05	2.10	2.15
0.10-0.20	SPECIFIED CLEARANCE/NO ADJUSTMENT REQUIRED																					
0.21-0.25		1.30	1.35	1.40	1.45	1.50	1.55	1.60	1.65	1.70	1.75	1.80	1.85	1.90	1.95	2.00	2.05	2.10	2.15	2.20	2.20	
0.26-0.30		1.35	1.40	1.45	1.50	1.55	1.60	1.65	1.70	1.75	1.80	1.85	1.90	1.95	2.00	2.05	2.10	2.15	2.20			
0.31-0.35		1.40	1.45	1.50	1.55	1.60	1.65	1.70	1.75	1.80	1.85	1.90	1.95	2.00	2.05	2.10	2.15	2.20				
0.36-0.40		1.45	1.50	1.55	1.60	1.65	1.70	1.75	1.80	1.85	1.90	1.95	2.00	2.05	2.10	2.15	2.20					
0.41-0.45		1.50	1.55	1.60	1.65	1.70	1.75	1.80	1.85	1.90	1.95	2.00	2.05	2.10	2.15	2.20						
0.46-0.50		1.55	1.60	1.65	1.70	1.75	1.80	1.85	1.90	1.95	2.00	2.05	2.10	2.15	2.20							
0.51-0.55		1.60	1.65	1.70	1.75	1.80	1.85	1.90	1.95	2.00	2.05	2.10	2.15	2.20								
0.56-0.60		1.65	1.70	1.75	1.80	1.85	1.90	1.95	2.00	2.05	2.10	2.15	2.20									
0.61-0.65		1.70	1.75	1.80	1.85	1.90	1.95	2.00	2.05	2.10	2.15	2.20										
0.66-0.70		1.75	1.80	1.85	1.90	1.95	2.00	2.05	2.10	2.15	2.20											
0.71-0.75		1.80	1.85	1.90	1.95	2.00	2.05	2.10	2.15	2.20												
0.76-0.80		1.85	1.90	1.95	2.00	2.05	2.10	2.15	2.20													
0.81-0.85		1.90	1.95	2.00	2.05	2.10	2.15	2.20														
0.86-0.90		1.95	2.00	2.05	2.10	2.15	2.20															
0.91-0.95		2.00	2.05	2.10	2.15	2.20																
0.96-1.00		2.05	2.10	2.15	2.20																	
1.01-1.05		2.10	2.15	2.20																		
1.06-1.10		2.15	2.20																			
1.11-1.15		2.20																				

**HOW TO USE THIS CHART:**

- I. Measure tappet clearance. "ENGINE IS COLD"
- II. Measure present shim size.
- III. Match clearance in vertical column with present shim size in horizontal column.

**EXAMPLE**

Tappet clearance is    0.23 mm  
Present shim size       1.65 mm  
Shim size to be used   1.75 mm

(EXHAUST SIDE)

TAPPET SHIM SELECTION TABLE [EXHAUST]  
 TAPPET SHIM NO. (12892-05C00-XXX)

TAPPET SHIM SET (12800-05830)

MEASURED TAPPET CLEARANCE (mm)	SUFFIX NO.	120	125	130	135	140	145	150	155	160	165	170	175	180	185	190	195	200	205	210	215	220
	PRESENT SHIM SIZE (mm)	1.20	1.25	1.30	1.35	1.40	1.45	1.50	1.55	1.60	1.65	1.70	1.75	1.80	1.85	1.90	1.95	2.00	2.05	2.10	2.15	2.20
0.05-0.09					1.20	1.25	1.30	1.35	1.40	1.45	1.50	1.55	1.60	1.65	1.70	1.75	1.80	1.85	1.90	1.95	2.00	2.05
0.10-0.14				1.20	1.25	1.30	1.35	1.40	1.45	1.50	1.55	1.60	1.65	1.70	1.75	1.80	1.85	1.90	1.95	2.00	2.05	2.10
0.15-0.19			1.20	1.25	1.30	1.35	1.40	1.45	1.50	1.55	1.60	1.65	1.70	1.75	1.80	1.85	1.90	1.95	2.00	2.05	2.10	2.15
0.20-0.30	SPECIFIED CLEARANCE/NO ADJUSTMENT REQUIRED																					
0.31-0.35		1.30	1.35	1.40	1.45	1.50	1.55	1.60	1.65	1.70	1.75	1.80	1.85	1.90	1.95	2.00	2.05	2.10	2.15	2.20	2.20	
0.36-0.40		1.35	1.40	1.45	1.50	1.55	1.60	1.65	1.70	1.75	1.80	1.85	1.90	1.95	2.00	2.05	2.10	2.15	2.20			
0.41-0.45		1.40	1.45	1.50	1.55	1.60	1.65	1.70	1.75	1.80	1.85	1.90	1.95	2.00	2.05	2.10	2.15	2.20				
0.46-0.50		1.45	1.50	1.55	1.60	1.65	1.70	1.75	1.80	1.85	1.90	1.95	2.00	2.05	2.10	2.15	2.20					
0.51-0.55		1.50	1.55	1.60	1.65	1.70	1.75	1.80	1.85	1.90	1.95	2.00	2.05	2.10	2.15	2.20						
0.56-0.60		1.55	1.60	1.65	1.70	1.75	1.80	1.85	1.90	1.95	2.00	2.05	2.10	2.15	2.20							
0.61-0.65		1.60	1.65	1.70	1.75	1.80	1.85	1.90	1.95	2.00	2.05	2.10	2.15	2.20								
0.66-0.70		1.65	1.70	1.75	1.80	1.85	1.90	1.95	2.00	2.05	2.10	2.15	2.20									
0.71-0.75		1.70	1.75	1.80	1.85	1.90	1.95	2.00	2.05	2.10	2.15	2.20										
0.76-0.80		1.75	1.80	1.85	1.90	1.95	2.00	2.05	2.10	2.15	2.20											
0.81-0.85		1.80	1.85	1.90	1.95	2.00	2.05	2.10	2.15	2.20												
0.86-0.90		1.85	1.90	1.95	2.00	2.05	2.10	2.15	2.20													
0.91-0.95		1.90	1.95	2.00	2.05	2.10	2.15	2.20														
0.96-1.00		1.95	2.00	2.05	2.10	2.15	2.20															
1.01-1.05		2.00	2.05	2.10	2.15	2.20																
1.06-1.10		2.05	2.10	2.15	2.20																	
1.11-1.15		2.10	2.15	2.20																		
1.16-1.20		2.15	2.20																			
1.21-1.25		2.20																				

**HOW TO USE THIS CHART:**

- I. Measure tappet clearance. "ENGINE IS COLD"
- II. Measure present shim size.
- III. Match clearance in vertical column with present shim size in horizontal column.

**EXAMPLE**

Tappet clearance is 0.33 mm  
 Present shim size 1.65 mm  
 Shim size to be used 1.75 mm



## FUEL LINE

Inspect every 6 000 km (4 000 miles, 12 months).  
Replace every 4 years.

- Lift and support the fuel tank. (☞ 5-7)
- Inspect the fuel feed hose (A) for damage and fuel leakage. If any defects are found, the fuel hoses must be replaced.

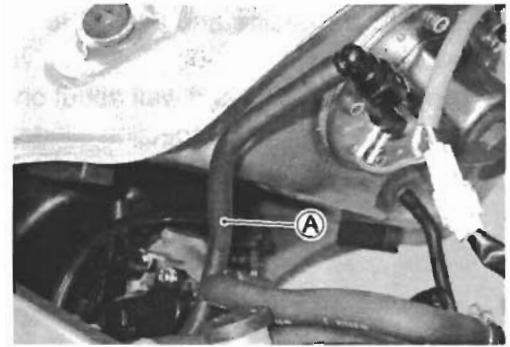

## ENGINE OIL AND OIL FILTER

### (ENGINE OIL)

Replace initially at 1 000 km (600 miles, 2 month) and every 6 000 km (4 000 miles, 12 months) thereafter.

### (OIL FILTER)

Replace initially at 1 000 km (600 miles, 2 month) and every 18 000 km (11 000 miles, 36 months) thereafter.

Oil should be changed while the engine is warm. Oil filter replacement at the above intervals, should be done together with the engine oil change.

## ENGINE OIL REPLACEMENT

- Keep the motorcycle upright.
- Place an oil pan below the engine, and drain oil by removing the drain plug (1) and filler cap (2).

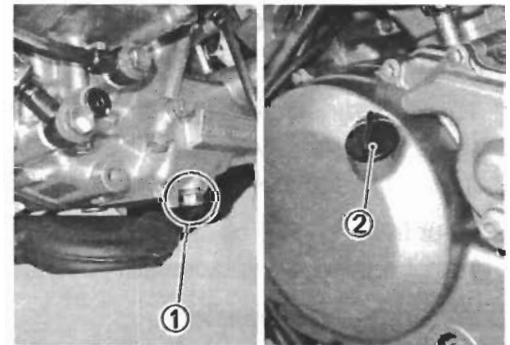

- Tighten the drain plug (3) to the specified torque, and pour fresh oil through the oil filler. The engine will hold about 2.7 L (2.9/2.4 US/Imp qt) of oil. Use an API classification of SF or SG oil with SAE 10W-40 viscosity.

 Oil drain plug: 21 N·m (2.1 kgf·m, 15.0 lb-ft)

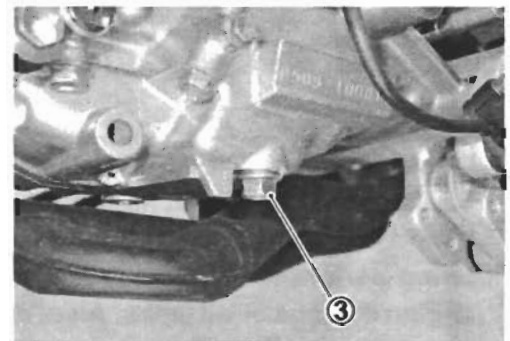

- Start up the engine and allow it to run for several minutes at idling speed.
- Turn off the engine and wait about one minute, then check the oil level through the inspection window **A**. If the level is below mark “L”, add oil to “F” level. If the level is above mark “F”, drain oil to “F” level.

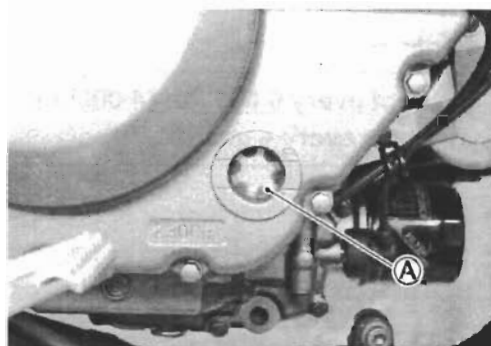

### OIL FILTER REPLACEMENT

- Drain engine oil in the same manner of engine oil replacement procedure.
- Remove the oil filter **1** with the special tool.

**TOOL** 09915-40610: Oil filter wrench

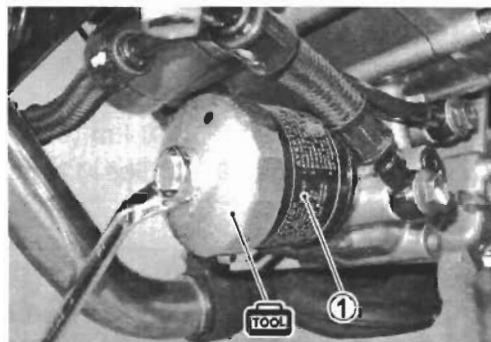

- Apply engine oil lightly to the gasket of the new filter **2** before installation.
- Install the new filter turning it by hand until you feel that the filter gasket contacts the mounting surface. Then tighten it 2 turns with the special tool.

**TOOL** 09915-40610: Oil filter wrench

#### NOTE:

- \* To properly tighten the filter, use the special tool. Never tighten the filter by hand.
- \* After contacting the gasket, tighten 2 turns.
- Pour fresh engine oil and check the oil level in the same manner of engine oil replacement procedure.

#### **DATA** Engine oil capacity

Oil change: 2.3 L (2.4/2.0 US/Imp qt)

Filter change: 2.7 L (2.9/2.4 US/Imp qt)

Engine overhaul: 3.1 L (3.3/2.7 US/Imp qt)

#### **CAUTION**

**ONLY USE A GENUINE SUZUKI MOTORCYCLE OIL FILTER.** Other manufacturer's oil filters may differ in thread specifications (thread diameter and pitch), filtering performance and durability which may lead to engine damage or oil leaks. Also, do not use a genuine Suzuki automobile oil filter on this motorcycle.

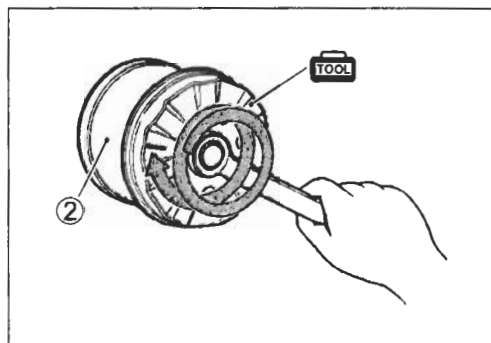

## ENGINE IDLE SPEED

Inspect initially at 1 000 km (600 miles, 2 month) and every 6 000 km (4 000 miles, 12 months) thereafter.

### NOTE:

Make this adjustment when the engine is hot.

- Start up the engine and set its idle speed to the specified range by turning the throttle stop screw ①.

**DATA** Engine idle speed: 1 300 ± 100 r/min

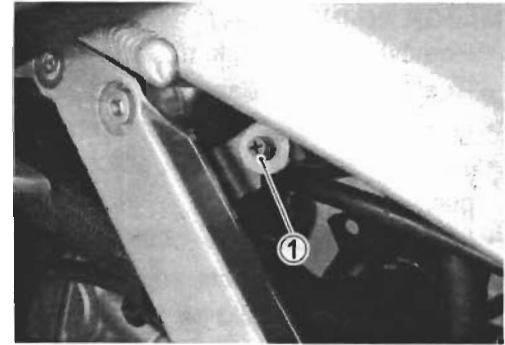

## THROTTLE CABLE PLAY

Inspect initially at 1 000 km (600 miles, 2 month) and every 6 000 km (4 000 miles, 12 months) thereafter.

Adjust the throttle cable play ① with the following three steps.

### MINOR ADJUSTMENT

First step:

- Remove the cable adjuster covers ①.
- Loosen the lock-nut ② of the throttle returning cable ③ and turn in the adjuster ④ fully into the threads.

Second step:

- Loosen the lock-nut ⑤ of the throttle pulling cable ⑥.
- Turn the adjuster ⑦ in or out until the throttle cable play ① should be 2.0 – 4.0 mm (0.08 – 0.16 in) at the throttle grip.
- Tighten the lock-nut ⑤ while holding the adjuster ⑦.

Third step:

- While holding the throttle grip at the fully closed position, slowly turn out the adjuster ④ of the throttle returning cable ① to feel resistance.
- Tighten the lock-nut ③ while holding the adjuster ④.

**DATA** Throttle cable play ①: 2.0 – 4.0 mm (0.08 – 0.16 in)

### ⚠ WARNING

After the adjustment is completed, check that handlebar movement does not raise the engine idle speed and that the throttle grip returns smoothly and automatically.

### NOTE:

Major adjustment can be made by the throttle body side adjuster.

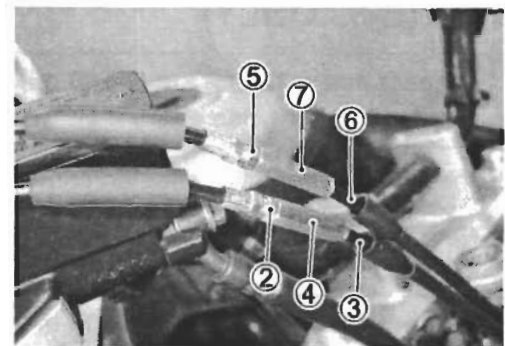
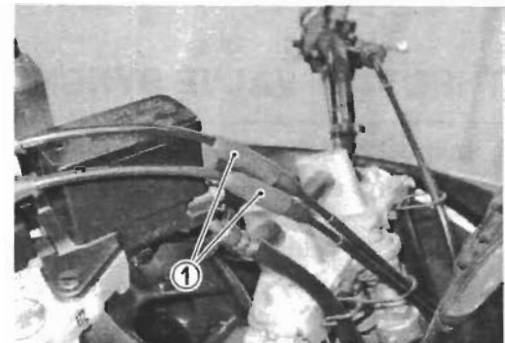
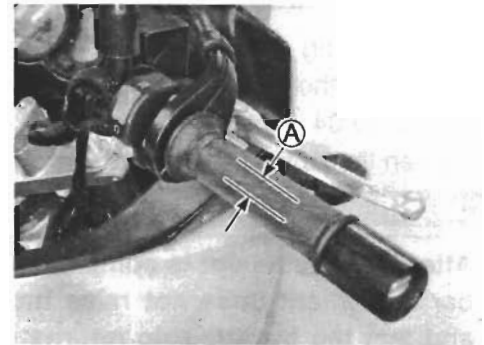

**MAJOR ADJUSTMENT**

- Remove the fuel tank. (☞ 5-7)
- Remove the air cleaner box. (☞ 5-15)
- Loosen the lock-nut ① of the throttle returning cable.
- Turn the returning cable adjuster ② to obtain proper cable play.
- Loosen the lock-nut ③ of the throttle pulling cable.
- Turn the pulling cable adjuster ④ in or out until the throttle cable play **A** should be 2.0 – 4.0 mm (0.08 – 0.16 in) at the throttle grip.
- Tighten the lock-nut ③ securely while holding the adjuster ④.

**DATA** Throttle cable play **A**: 2.0 – 4.0 mm (0.08 – 0.16 in)

- While holding the throttle grip at the fully closed position, slowly turn the returning cable adjuster ② to obtain a slack of 1.0 mm (0.04 in).
- Tighten the lock-nut ① securely.

**⚠ WARNING**

After the adjustment is completed, check that handlebar movement does not raise the engine idle speed and that the throttle grip returns smoothly and automatically.

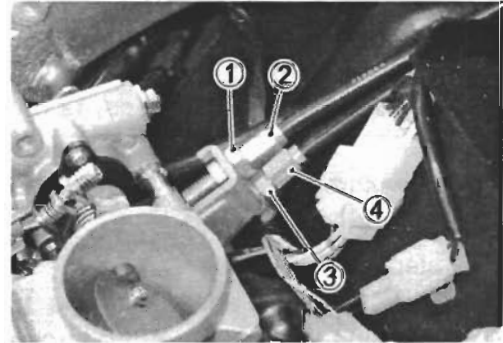
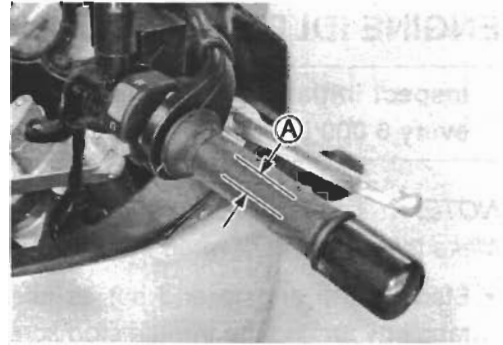
**THROTTLE VALVE SYNCHRONIZATION**

Inspect initially at 1 000 km (600 miles, 2 months) (E-33 only) and every 12 000 km (7 500 miles, 24 months).

Inspect the throttle valve synchronization periodically. (☞ 5-32)

**EVAPORATIVE EMISSION CONTROL SYSTEM (E-33 ONLY)**

Inspect every 12 000 km (7 500 miles, 24 months).  
Replace vapor hose every 4 years.

Inspect the evaporative emission control system periodically.

**PAIR (AIR SUPPLY) SYSTEM**

Inspect every 12 000 km (7 500 miles, 24 months).

Inspect the PAIR (air supply) system periodically. (☞ 10-6)

## CLUTCH

**Inspect every 6 000 km (4 000 miles, 12 months).**

- Loosen the lock-nut ① and turn the adjuster ② all the way into the clutch lever assembly.

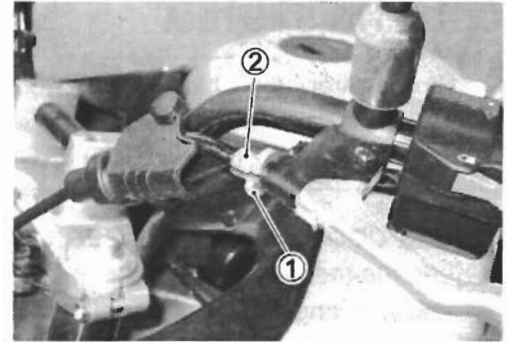

- Remove the engine sprocket cover.

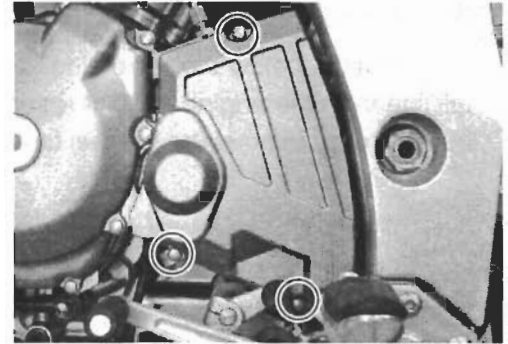

- Loosen the lock-nut ③ and turn out the adjusting screw ④ two or three rotations.
- From that position, slowly turn the adjuster screw ③ in until it stops.
- Turn the adjuster screw ③ out 1/4 rotation, and tighten the lock-nut ④.

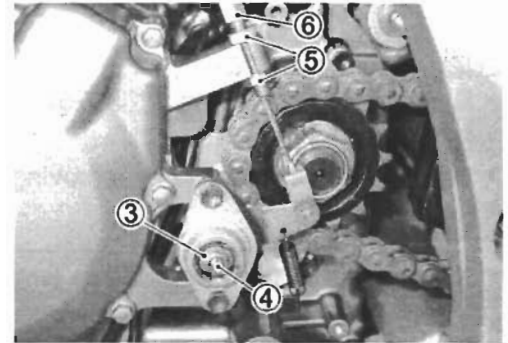

- Loosen the lock-nuts ⑤, turn the cable adjuster ⑥ to obtain 10 – 15 mm (0.4 – 0.6 in) of free play ① at the clutch lever end.
- Tighten the lock-nuts ⑤.

**DATA** Clutch cable play ①: 10 – 15 mm (0.4 – 0.6 in)  
Clutch release screw: 1/4 turns back.

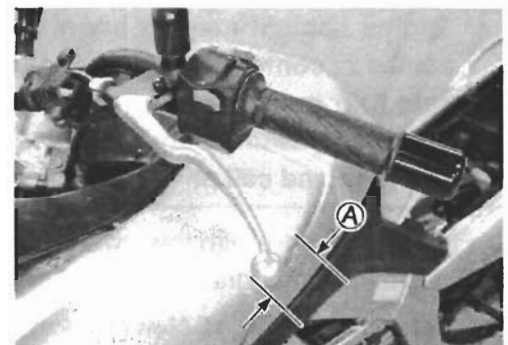

## COOLING SYSTEM

Inspect every 6 000 km (4 000 miles, 12 months).  
 Replace engine coolant every 2 years.  
 Replace radiator hoses every 4 years.

### ENGINE COOLANT LEVEL CHECK

- Keep the motorcycle upright.
- Check the engine coolant level by observing the full and lower lines on the engine coolant reserve tank.
  - Ⓐ Full line      Ⓑ Lower line
- If the level is below the lower line, add engine coolant to the full line from the engine coolant reserve tank filler. To remove the filler cap, remove the left fuel tank side cover. (☞ 7-4)

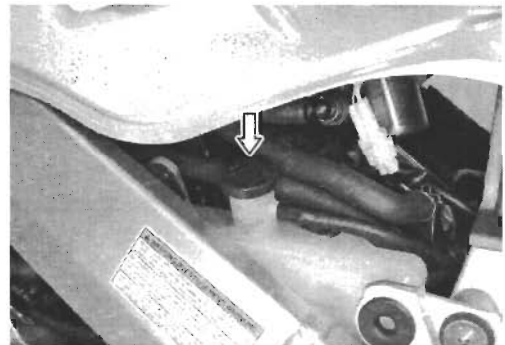
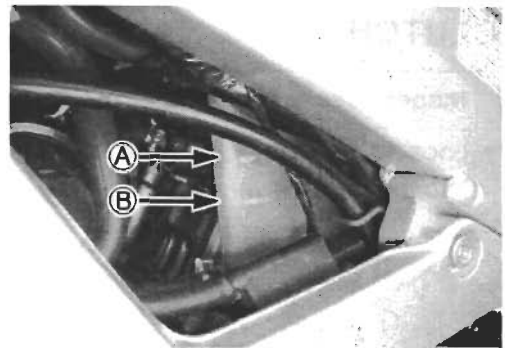

### ENGINE COOLANT CHANGE

- Remove the left cowling. (☞ 7-5)
- Remove the radiator cap ①.
- Drain the engine coolant by removing the drain bolt Ⓐ.

#### **⚠ WARNING**

- \* Do not open the radiator cap when the engine is hot, as you may be injured by escaping hot liquid or vapor.
- \* Engine coolant may be harmful if swallowed or if it comes in contact with skin or eyes. If engine coolant gets into the eyes or in contact with the skin, flush thoroughly with plenty of water. If swallowed, induce vomiting and call physician immediately!

- Flush the radiator with fresh water if necessary.
- Tighten the water drain bolt Ⓐ to the specified torque.

#### **🔧 Water drain bolt: 13 N·m (1.3 kgf-m, 9.5 lb-ft)**

- Pour the specified engine coolant up to the radiator inlet.
- Bleed the air from the engine coolant circuit as following procedure.

#### **NOTE:**

For engine coolant information, refer to page 6-2.

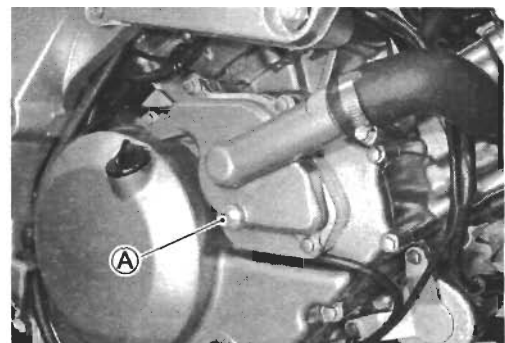

**AIR BLEEDING THE COOLING CIRCUIT**

- Add engine coolant up to the radiator inlet.
- Support the motorcycle upright.
- Slowly swing the motorcycle, right and left, to bleed the air trapped in the cooling circuit.
- Add engine coolant up to the radiator inlet.

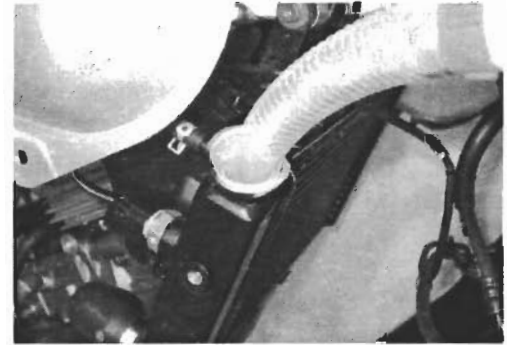

- Start up the engine and bleed air from the radiator inlet completely.
- Lightly tap the thermostat case ① and slowly swing the motorcycle, right and left, to bleed the air trapped in the thermostat case ①.

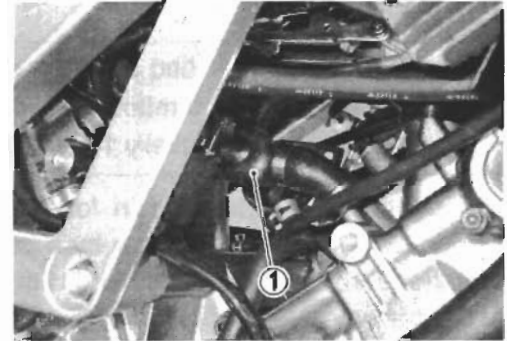

- Add engine coolant up to the radiator inlet.
- Repeat the above procedure until bleed no air from the radiator inlet.

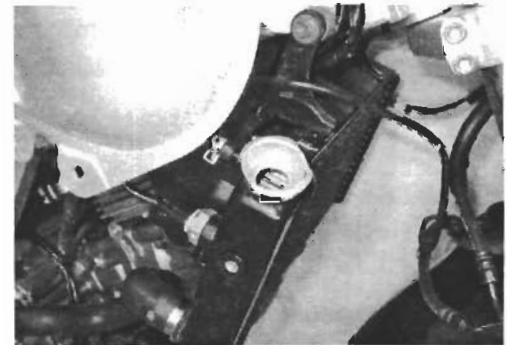

- Close the radiator cap ② securely.
- After warming up and cooling down the engine several times, add the engine coolant up to the full level of the reserve tank.
- Install the cowling. (☞ 7-8)

**CAUTION**

Repeat the above procedure several times and make sure that the radiator is filled with engine coolant up to the reserve tank full level.

**LLC Engine coolant capacity**

Reverse tank side: 250 ml (0.53/0.44 US/Imp qt)

Engine side: 1 650 ml (3.49/2.90 US/Imp qt)

**RADIATOR HOSES**

- Remove the cowling. (☞ 7-5)
- Check to see the radiator hoses for crack, damage or engine coolant leakage.
- If any defects are found, replace the radiator hoses with new ones.

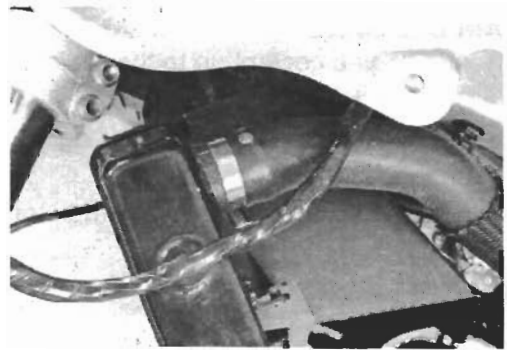
**DRIVE CHAIN**

Inspect initially at 1 000 km (600 miles, 2 month) and every 6 000 km (4 000 miles, 12 months) thereafter.  
Clean and Lubricate every 1 000 km (600 miles).

Visually check the drive chain for the possible defects listed below. (Support the motorcycle by a jack and a wooden block, turn the rear wheel slowly by hand with the transmission shifted to Neutral.)

- |                           |                             |
|---------------------------|-----------------------------|
| * Loose pins              | * Excessive wear            |
| * Damaged rollers         | * Improper chain adjustment |
| * Dry or rusted links     | * Missing O-ring seals      |
| * Kinked or binding links |                             |

- ① O-ring  
② Grease

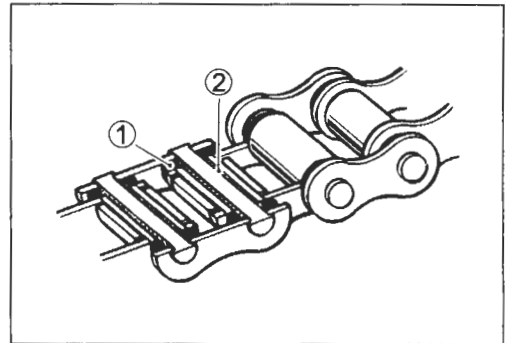

If any defects are found, the drive chain must be replaced.

**NOTE:**

When replacing the drive chain, replace the drive chain and sprockets as a set.

**CHECKING**

- Remove the cotter pin. (For E-03, 28, 33)
- Loosen the axle nut ①.
- Tense the drive chain fully by turning both chain adjusters ②.

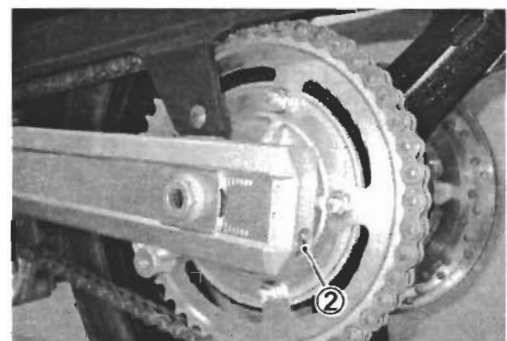
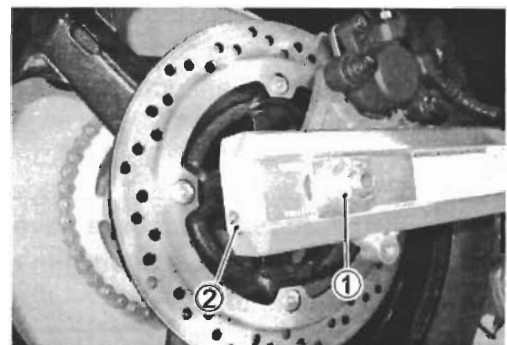



- Count out 21 pins (20 pitches) on the chain and measure the distance between the two points. If the distance exceeds the service limit, the chain must be replaced.

**DATA** Drive chain 20-pitch length  
**Service Limit: 319.4 mm (12.57 in)**

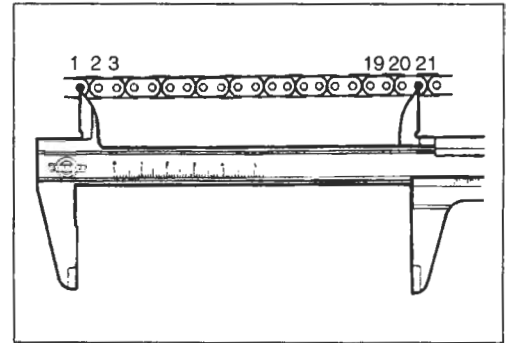

**ADJUSTING**

- Loosen or tighten both chain adjusters ① until the chain has 20 – 30 mm (0.8 – 1.2 in) of slack ① in the middle between engine and rear sprockets. The ends of left and right spacers must be at the same position on the scales ② to ensure that the front and rear wheels are correctly aligned.
- Place the motorcycle on its side-stand for accurate adjustment.
- After adjusting the drive chain, tighten the axle nut ② to the specified torque.
- Recheck the drive chain slack after tightening the axle nut ①.

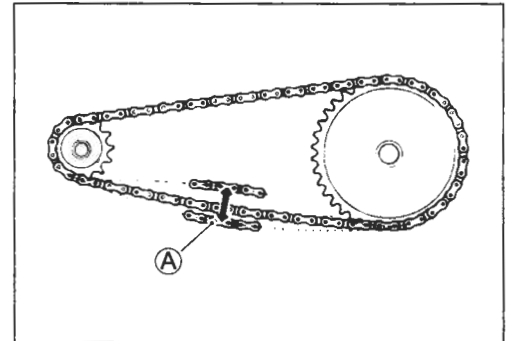

**U** Rear axle nut: 100 N·m (10.0 kgf-m, 72.5 lb-ft)

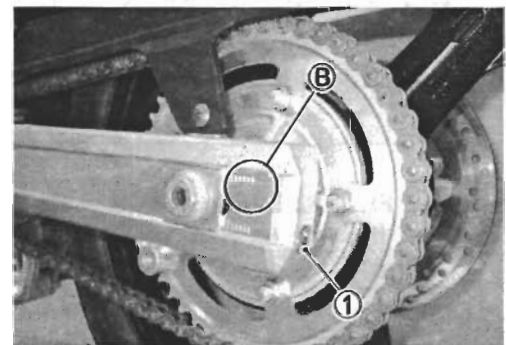
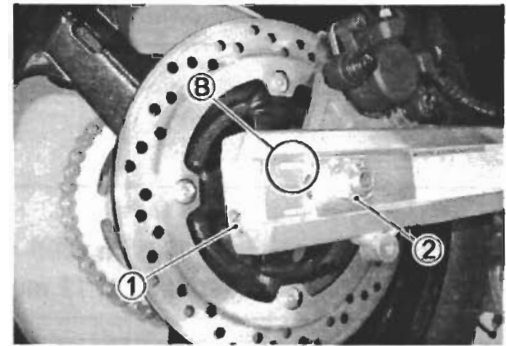

**CLEANING AND LUBRICATING**

- Wash the chain with kerosene. If the chain tends to rust quickly, the intervals must be shortened.

**CAUTION**

Do not use trichlene, gasoline or any similar fluids: These fluids have too great a dissolving power for this chain and, what is more important, they can damage the “O”-rings (or seals) confining the grease in the bush to pin clearance. Remember, high durability comes from the presence of grease in that clearance.

- After washing and drying the chain, oil it with a heavy-weight motor oil.

**CAUTION**

- \* Do not use any oil sold commercially as “drive chain oil”. Such oil can damage the “O”-rings (or seals).
- \* The standard drive chain is DID525V8. SUZUKI recommends that this standard drive chain should be used for the replacement.

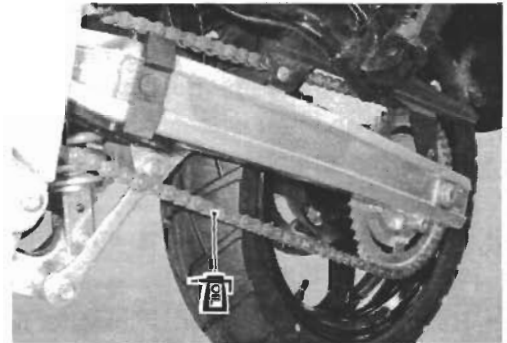
**BRAKE****(BRAKE)**

Inspect initially at 1 000 km (600 miles, 2 month) and every 6 000 km (4 000 miles, 12 months) thereafter.

**(BRAKE HOSE AND BRAKE FLUID)**

Inspect every 6 000 km (4 000 miles, 12 months). Replace hoses every 4 years. Replace fluid every 2 years.

**BRAKE FLUID LEVEL CHECK**

- Keep the motorcycle upright and place the handlebars straight.
- Check the brake fluid level by observing the lower limit lines on the front and rear brake fluid reservoirs.
- When the level is below the lower limit line, replenish with brake fluid that meets the following specification.



**Specification and Classification: DOT 4**

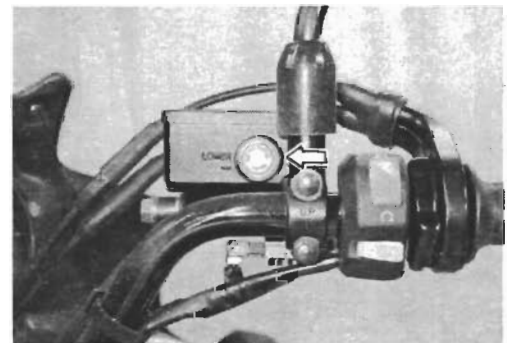

**⚠ WARNING**

The brake system of this motorcycle is filled with a glycol-based brake fluid. Do not use or mix different types of fluid such as silicone-based or petroleum-based. Do not use any brake fluid taken from old, used or unsealed containers. Never re-use brake fluid left over from the last servicing or stored for a long period.

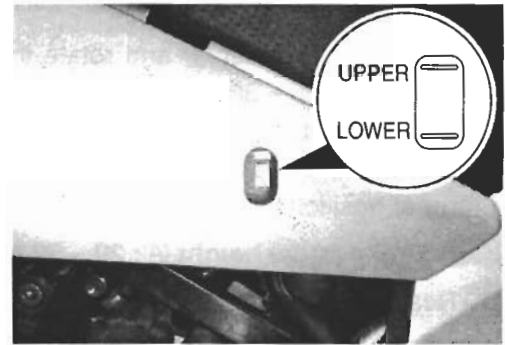
**⚠ WARNING**

Brake fluid, if it leaks, will interfere with safe running and immediately discolor painted surfaces. Check the brake hoses and hose joints for cracks and oil leakage before riding.

**BRAKE PADS**

- Remove the brake caliper. (Front)
- The extent of brake pad wear can be checked by observing the grooved limit (A) on the pad. When the wear exceeds the grooved limit, replace the pads with the new ones. (➡ 7-59 and - 69)

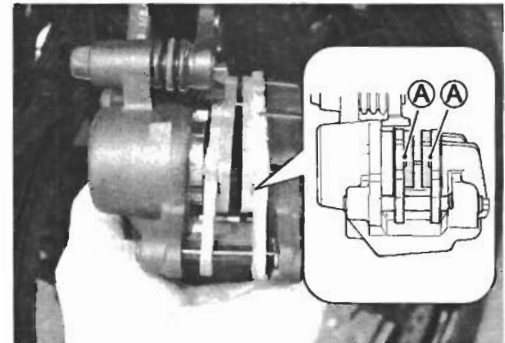
**CAUTION**

Replace the brake pad as a set, otherwise braking performance will be adversely affected.

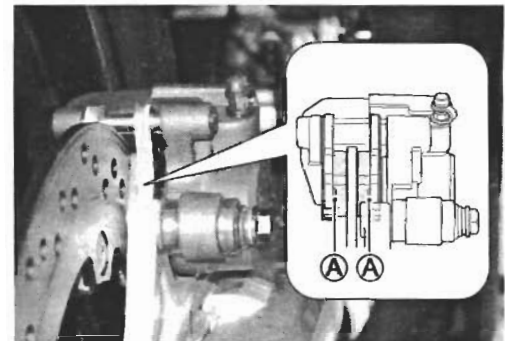

**BRAKE PEDAL HEIGHT**

- Loosen the lock-nut ① and rotate the push rod ② to locate brake pedal 20 – 30 mm (0.59 – 0.98 in) Ⓐ below the top face of the footrest.
- Retighten the lock-nut ① to secure the push rod ② in the proper position.

**DATA** Brake pedal height Ⓐ: 20 – 30 mm (0.79 – 1.18 in)

**🔧** Rear brake master cylinder rod lock-nut ①:  
17 N·m (1.7 kgf-m, 12.5 lb-ft)

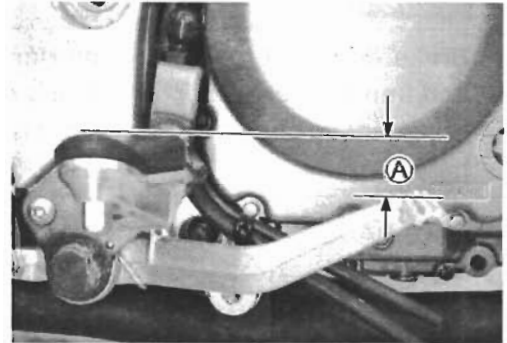
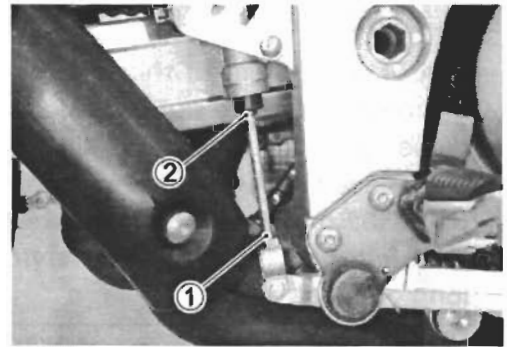

**REAR BRAKE SWITCH**

Adjust the rear brake switch so that the brake light will come on just before pressure is felt when the brake pedal is depressed.

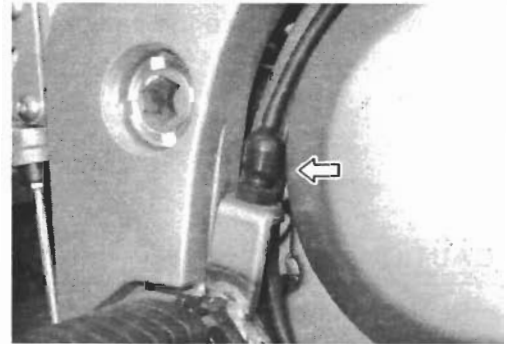

### AIR BLEEDING THE BRAKE FLUID CIRCUIT

Air trapped in the fluid circuit acts like a cushion to absorb a large proportion of the pressure developed by the master cylinder and thus interferes with the full braking performance of the brake caliper. The presence of air is indicated by “sponginess” of the brake lever and also by lack of braking force. Considering the danger to which such trapped air exposes the machine and rider, it is essential that, after remounting the brake and restoring the brake system to the normal condition, the brake fluid circuit be purged of air in the following manner:

- Fill up the master cylinder reservoir to the “UPPER” line. Place the reservoir cap to prevent entry of dirt.
- Attach a pipe to the air bleeder valve, and insert the free end of the pipe into a receptacle.

**🔧 Air bleeder valve (Front): 7.5 N·m (0.75 kgf·m, 5.5 lb·ft)**  
**🔧 Air bleeder valve (Rear): 6 N·m (0.6 kgf·m, 4.3 lb·ft)**

- Front brake: Bleed the air from the air bleeder valve.
- Squeeze and release the brake lever several times in rapid succession and squeeze the lever fully without releasing it. Loosen the bleeder valve by turning it a quarter of a turn so that the brake fluid runs into the receptacle; this will remove the tension of the brake lever causing it to touch the handlebar grip. Then, close the valve, pump and squeeze the lever, and open the valve. Repeat this process until the fluid flowing into the receptacle no longer contains air bubbles.

#### NOTE:

Replenish the brake fluid in the reservoir as necessary while bleeding the brake system. Make sure that there is always some fluid visible in the reservoir.

- Close the bleeder valve, and disconnect the pipe. Fill the reservoir with brake fluid to the “UPPER” line.

#### CAUTION

**Handle brake fluid with care: the fluid reacts chemically with paint, plastics, rubber materials and so on.**

- The only difference between bleeding the front and rear brakes is that the rear master cylinder is actuated by a pedal.

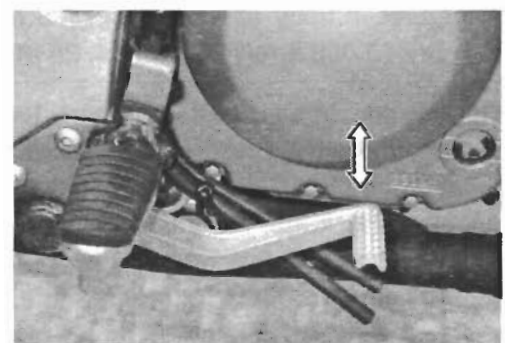
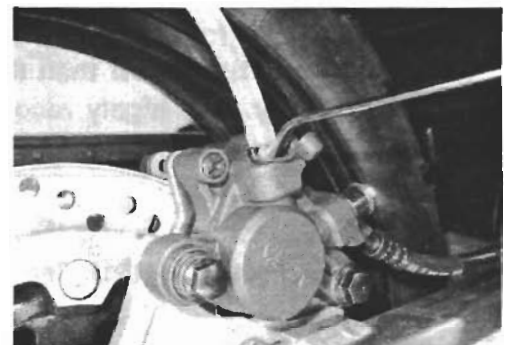
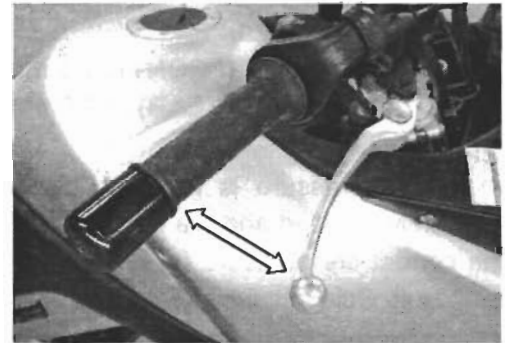
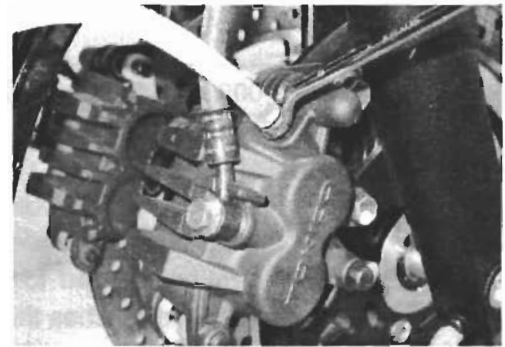

## TIRE

Inspect every 6 000 km (4 000 miles, 12 months).

### TIRE TREAD CONDITION

Operating the motorcycle with excessively worn tires will decrease riding stability and consequently invite a dangerous situation. It is highly recommended to replace a tire when the remaining depth of tire tread reaches the following specification.

**TOOL** 09900-20805: Tire depth gauge

**DATA** Tire tread depth

Service Limit (FRONT) : 1.6 mm (0.06 in)  
(REAR) : 2.0 mm (0.08 in)

### TIRE PRESSURE

If the tire pressure is too high or too low, steering will be adversely affected and tire wear increased. Therefore, maintain the correct tire pressure for good roadability or shorter tire life will result. Cold inflation tire pressure is as follows.

COLD INFLATION TIRE PRESSURE	SOLO RIDING			DUAL RIDING		
	kPa	kgf/cm <sup>2</sup>	psi	kPa	kgf/cm <sup>2</sup>	psi
FRONT	225	2.25	33	225	2.25	33
REAR	250	2.50	36	280	2.80	41

### CAUTION

The standard tire fitted on this motorcycle is 110/80 R19M/C (59H) for front and 150/70 R17M/C (69H) for rear. The use of tires other than those specified may cause instability. It is highly recommended to use a SUZUKI Genuine Tire.

### TIRE TYPE

BRIDGESTONE (Front : TW101F Rear : TW152F)

## STEERING

Inspect initially at 1 000 km (600 miles, 2 month) and every 12 000 km (7 500 miles, 24 months) thereafter.

Steering should be adjusted properly for smooth turning of handlebars and safe running. Overtight steering prevents smooth turning of the handlebars and too loose steering will cause poor stability. Check that there is no play in the steering stem while grasping the lower fork tubes by supporting the machine so that the front wheel is off the ground, with the wheel straight ahead, and pull forward. If play is found, perform steering bearing adjustment as described in page 7-31 of this manual.

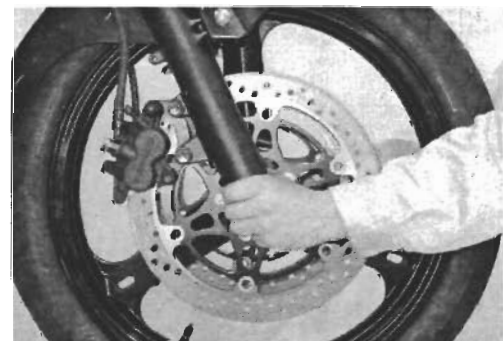
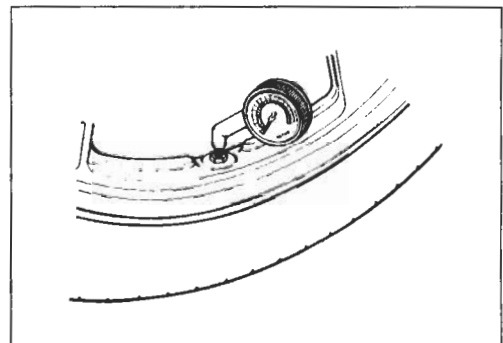
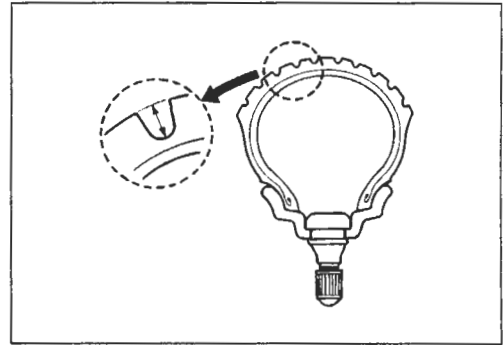

## FRONT FORK

Inspect every 12 000 km (7 500 miles, 12 months).

Inspect the front forks for oil leakage, scoring or scratches on the outer surface of the inner tubes. Replace any defective parts, if necessary. (☞ 7-17)



## REAR SUSPENSION

Inspect every 12 000 km (7 500 miles, 12 months).

Inspect the damper for oil leakage and the spring unit for damage. Check that there is no play in the swingarm assembly. Replace any defective parts, if necessary. (☞ 7-45)

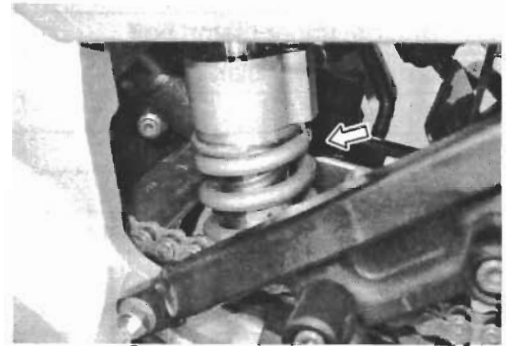

## EXHAUST PIPE BOLT

Tighten initially at 1 000 km (600 miles, 2 month) and every 6 000 km (4 000 miles, 12 months) thereafter.

- Tighten the exhaust pipe bolts and muffler mounting bolts to the specified torque.

 Muffler mounting bolt /nut (A): 23 N·m (2.3 kgf-m, 16.5 lb-ft)  
Exhaust pipe bolt (B)(C)(D): 23 N·m (2.3 kgf-m, 16.5 lb-ft)

 99000-32050: THREAD LOCK “1342”

EXHAUST GAS SEALER: PERMATEX 1372

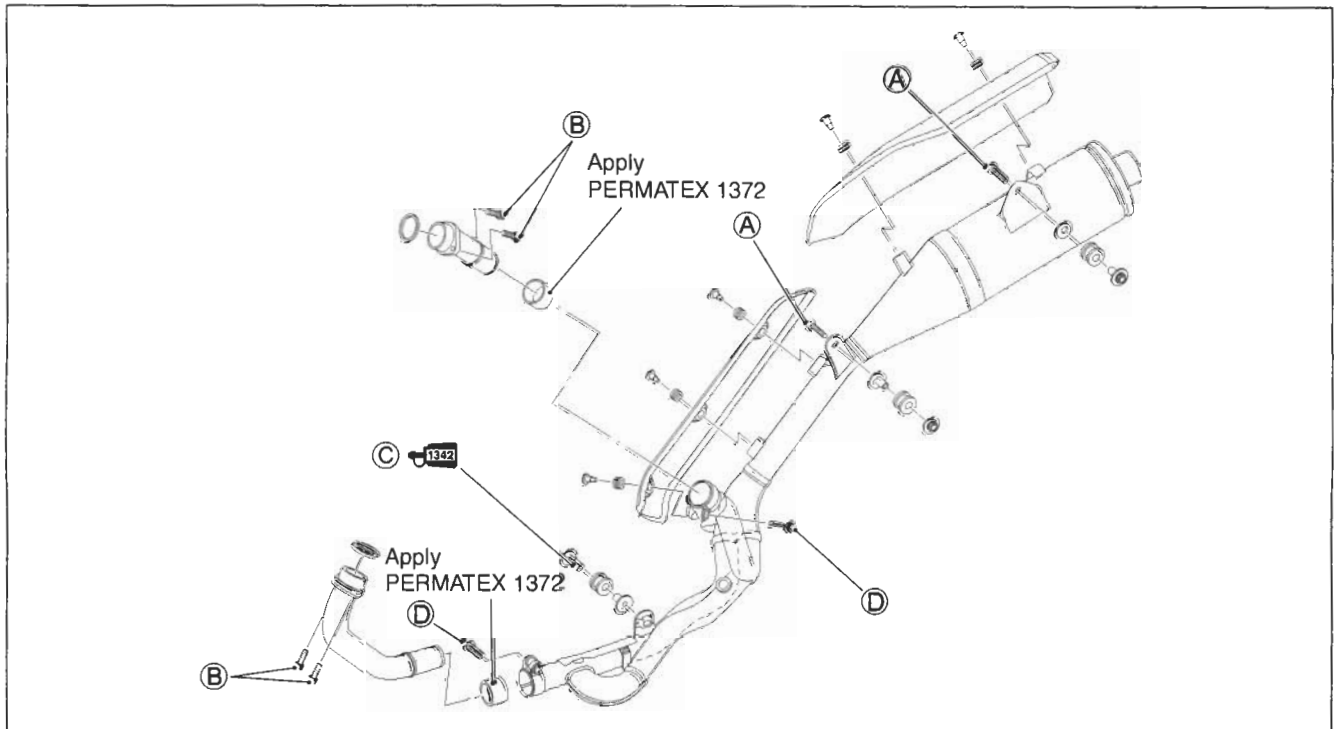

## CHASSIS BOLT AND NUT

**Tighten initially at 1 000 km (600 miles, 2 month) and every 6 000 km (4 000 miles, 12 months) thereafter.**

Check that all chassis bolts and nuts are tightened to their specified torque. (Refer to page 2-29 for the locations of the following nuts and bolts on the motorcycle.)

ITEM	N·m	kgf-m	lb-ft
① Steering stem head nut	90	9.0	65.0
② Steering stem lock-nut	80	8.0	58.0
③ Front fork upper clamp bolt	23	2.3	16.5
④ Front fork lower clamp bolt	23	2.3	16.5
⑤ Front axle	65	6.5	47.0
⑥ Front axle pinch bolt	23	2.3	16.5
⑦ Handlebar clamp bolt	23	2.3	16.5
⑧ Front brake master cylinder mounting bolt	10	1.0	7.0
⑨ Front brake caliper mounting bolt	39	3.9	28.0
⑩ Brake hose union bolt	23	2.3	16.5
⑪ Air bleeder valve (Front)	7.5	0.75	5.5
⑫ Air bleeder valve (Rear)	6	0.6	4.3
⑬ Brake disc bolt (Front & Rear)	23	2.3	16.5
⑭ Rear brake caliper mounting bolt	22	2.2	16.0
⑮ Rear brake master cylinder mounting bolt	10	1.0	7.0
⑯ Rear brake master cylinder rod lock-nut	18	1.8	13.0
⑰ Front footrest bracket mounting bolt	25	2.5	18.0
⑱ Swingarm pivot nut	100	10.0	72.5
⑲ Swingarm pivot lock-nut	90	9.0	65.0
⑳ Rear shock absorber mounting nut (Upper & Lower)	50	5.0	36.0
㉑ Cushion lever nut	78	7.8	56.5
㉒ Cushion rod nut	78	7.8	56.5
㉓ Rear axle nut	100	10.0	72.5
㉔ Seat rail mounting bolt	50	5.0	36.0



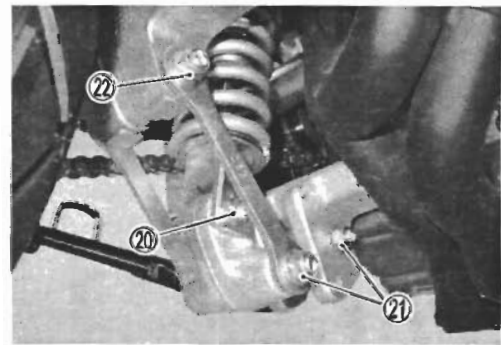
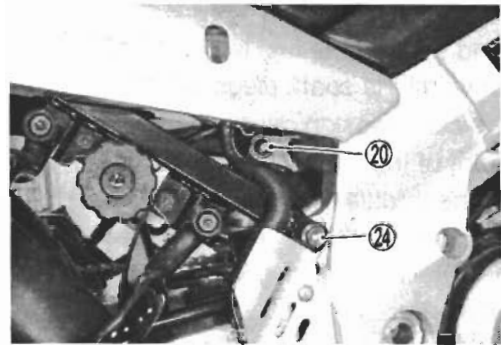
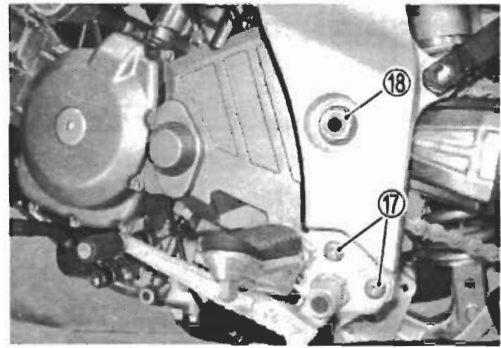
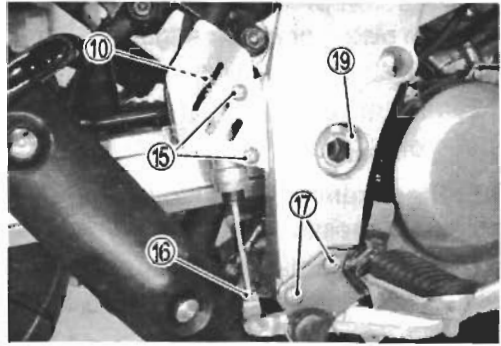
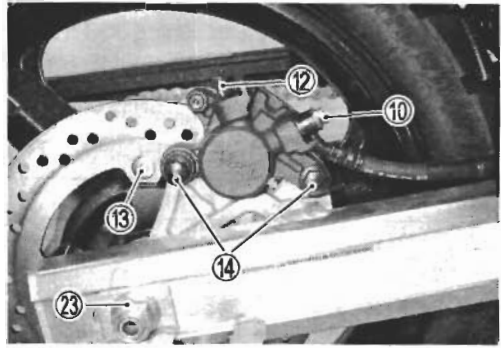
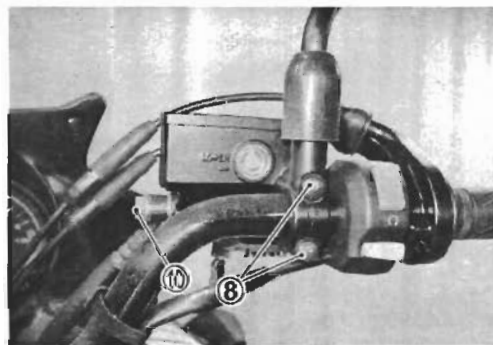
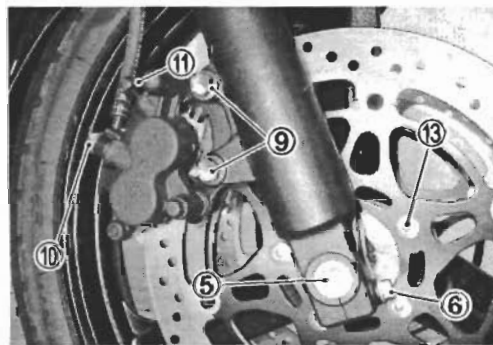
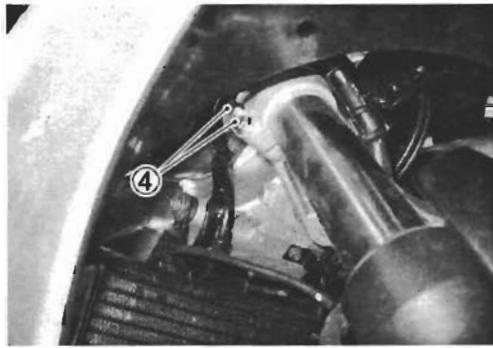
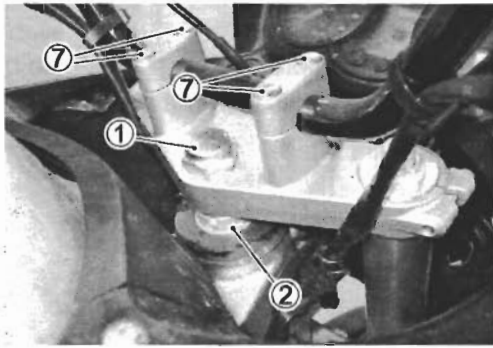

## COMPRESSION PRESSURE CHECK

The compression of a cylinder is a good indicator of its internal condition.

The decision to overhaul the cylinder is often based on the results of a compression test. Periodic maintenance records kept at your dealership should include compression readings for each maintenance service.

COMPRESSION PRESSURE SPECIFICATION (Automatic de-comp. actuated)

Standard	Limit	Difference
1 300 – 1 700 kPa (13 – 17 kgf/cm <sup>2</sup> ) (185 – 242 psi)	1 100 kPa (11 kgf/cm <sup>2</sup> ) (156 psi)	200 kPa (2 kgf/cm <sup>2</sup> ) (28 psi)

**Low compression pressure can indicate any of the following conditions:**

- \* Worn-down piston or piston rings
- \* Piston rings stuck in grooves
- \* Poor seating of valves
- \* Ruptured or otherwise defective cylinder head gasket

**Overhaul the engine in the following cases:**

- \* Compression pressure in one of the cylinders is 1 100 kPa (11 kgf/cm<sup>2</sup>, 156 psi) and less.
- \* Difference in compression pressure between two cylinders is 200 kPa (2 kgf/cm<sup>2</sup>, 28 psi) and more.
- \* All compression pressure are below 1 300 kPa (13 kgf/cm<sup>2</sup>, 185 psi) even when they measure 1 100 kPa (11 kgf/cm<sup>2</sup>, 156 psi) and more.

## COMPRESSION TEST PROCEDURE

**NOTE:**

- \* Before testing the engine for compression pressure, make sure that the cylinder head bolts are tightened to the specified torque values and valves are properly adjusted.
- \* Have the engine warmed up by idling before testing.
- \* Be sure that the battery used is in fully-charged condition.

Remove the parts concerned and test the compression pressure in the following manner.

- Lift and support the fuel tank. (☞ 5-7)
- Remove all the spark plugs. (☞ 2-6)
- Fit the compression gauge in one of the plug holes, while taking care of the tight connection.
- Keep the throttle grip in full-open position.
- While cranking the engine a few seconds with the starter, and record the maximum gauge reading as the compression of that cylinder.
- Repeat this procedure with an other cylinder.

 **09915-64512: Compression gauge**  
**09913-10750: Adaptor**

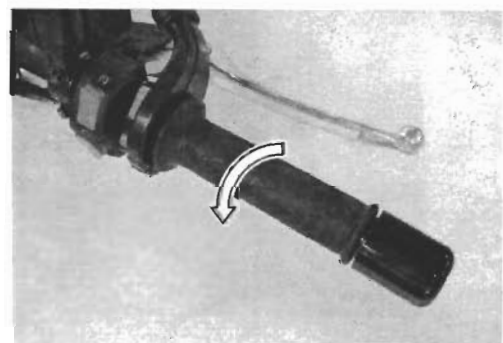
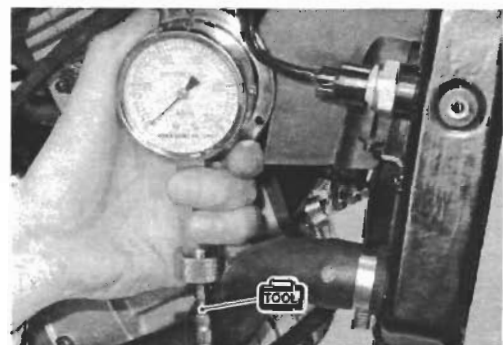

## OIL PRESSURE CHECK

Check periodically the oil pressure in the engine to judge roughly the condition of the moving parts.

### OIL PRESSURE SPECIFICATION

<p><b>Above 100 kPa (1.0 kgf/cm<sup>2</sup>, 14 psi)</b>  <b>Below 400 kPa (4.0 kgf/cm<sup>2</sup>, 57 psi)</b></p>	<p><b>at 3 000 r/min., Oil temp. at 60 °C (140 °F)</b></p>
---	--

If the oil pressure is lower or higher than the specification, the following causes may be considered.

### LOW OIL PRESSURE

- \* Clogged oil filter
- \* Oil leakage from the oil passage way
- \* Damaged O-ring
- \* Defective oil pump
- \* Combination of the above items

### HIGH OIL PRESSURE

- \* Used of high viscosity engine oil
- \* Clogged oil passage way
- \* Combination of the above items

### OIL PRESSURE TEST PROCEDURE

Start the engine and check if the oil pressure indicator light is turned on. If it keeps on lighting, check the oil pressure indicator light circuit. If it is in good condition, check the oil pressure in the following manner.

- Remove the main oil gallery plug ①.
  - Install the oil pressure gauge with attachment in the position shown in the figure.
- Warm up the engine as follows:  
 Summer 10 min. at 2 000 r/min.  
 Winter 20 min. at 2 000 r/min.
  - After warming up, increase the engine speed to 3 000 r/min. (with the engine tachometer), and read the oil pressure gauge.

-  **09915-74521: Oil pressure gauge hose**
- 09915-74532: Oil pressure gauge attachment**
- 09915-77331: Meter (for high pressure)**

-  **Main oil gallery plug [M 8]: 18 N·m (1.8 kgf·m, 13.0 lb-ft)**

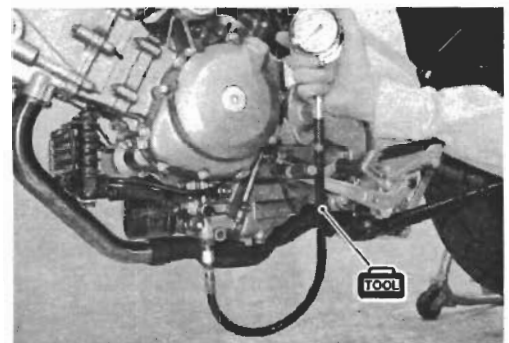

# ENGINE

## CONTENTS

<b>ENGINE COMPONENTS REMOVABLE WITH THE ENGINE IN PLACE</b> .....	<b>3- 2</b>
<b>ENGINE REMOVAL AND INSTALLATION</b> .....	<b>3- 3</b>
<b>ENGINE REMOVAL</b> .....	<b>3- 3</b>
<b>ENGINE INSTALLATION</b> .....	<b>3-11</b>
<b>ENGINE DISASSEMBLY</b> .....	<b>3-19</b>
<b>ENGINE TOP SIDE</b> .....	<b>3-19</b>
<b>ENGINE BOTTOM SIDE</b> .....	<b>3-26</b>
<b>ENGINE COMPONENTS INSPECTION AND SERVICING</b> .....	<b>3-36</b>
<b>CYLINDER HEAD COVER</b> .....	<b>3-36</b>
<b>CAMSHAFT/CAMSHAFT JOURNAL</b> .....	<b>3-37</b>
<b>CYLINDER HEAD</b> .....	<b>3-40</b>
<b>CYLINDER</b> .....	<b>3-50</b>
<b>PISTON AND PISTON RING</b> .....	<b>3-51</b>
<b>CONROD AND CRANKSHAFT</b> .....	<b>3-53</b>
<b>CRANKCASE</b> .....	<b>3-57</b>
<b>CRANKSHAFT JOURNAL BEARING</b> .....	<b>3-61</b>
<b>CRANKCASE BEARING AND OIL SEAL</b> .....	<b>3-66</b>
<b>CLUTCH</b> .....	<b>3-69</b>
<b>PRIMARY DRIVEN GEAR ASSEMBLY</b> .....	<b>3-70</b>
<b>GEARSHIFT SHAFT/GEARSHIFT ARM</b> .....	<b>3-71</b>
<b>TRANSMISSION</b> .....	<b>3-72</b>
<b>STARTER CLUTCH</b> .....	<b>3-79</b>
<b>GENERATOR AND SIGNAL GENERATOR</b> .....	<b>3-80</b>
<b>OIL PUMP</b> .....	<b>3-81</b>
<b>CLUTCH RELEASE</b> .....	<b>3-81</b>
<b>ENGINE REASSEMBLY</b> .....	<b>3-82</b>
<b>ENGINE BOTTOM SIDE</b> .....	<b>3-82</b>
<b>ENGINE TOP SIDE</b> .....	<b>3-94</b>

## ENGINE COMPONENTS REMOVABLE WITH THE ENGINE IN PLACE

Engine components which can be removed while the engine is installed on the chassis are listed below. For the installing and removing procedures, refer to respective paragraphs describing each component.

### ENGINE LEFT SIDE

PARTS	REMOVAL	INSTALLATION
Engine sprocket	3-6	3-16
Generator	3-26, 3-32	3-86, 3-93
Gear position switch	3-33	3-85
Clutch release	3-5	3-17
Starter idle gear	3-26	3-93

### ENGINE RIGHT SIDE

PARTS	REMOVAL	INSTALLATION
Clutch	3-27	3-90
Primary driven gear	3-29, 3-70	3-70, 3-90
Primary drive gear	3-31	3-87
Oil pump	3-29	3-89
Gearshift shaft	3-30	3-89
Water pump	6-14	6-17

### ENGINE CENTER

PARTS	REMOVAL	INSTALLATION
Throttle body	5-15	5-23
Cylinder head covers	3-20	3-106
Camshafts	3-21, 3-23	3-99
Cylinder heads	3-22, 3-25	3-97
Cylinders	3-23, 3-25	3-96
Pistons	3-23, 3-26	3-94
Cam chain tension adjusters	3-22, 3-24	3-101, 3-104
Thermostat	6-12	6-13
Oil filter	2-14	2-14
Oil pressure switch	3-58	3-58
Starter motor	3-26	3-94

## ENGINE REMOVAL AND INSTALLATION

### ENGINE REMOVAL

Before taking the engine out of the frame, wash the engine using a steam cleaner. Engine removal is sequentially explained in the following steps. Reinstall the engine by reversing the removal procedure.

- Drain the engine oil. (☞2-13)
- Drain the engine coolant. (☞2-18)
- Remove the seat. (☞7-4)
- Disconnect the battery ⊖ lead wire ①.

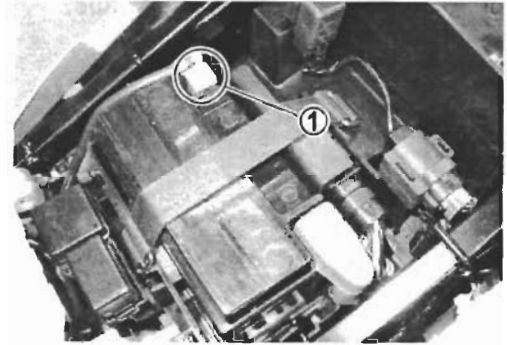

- Remove the fuel tank ②. (☞5-7)

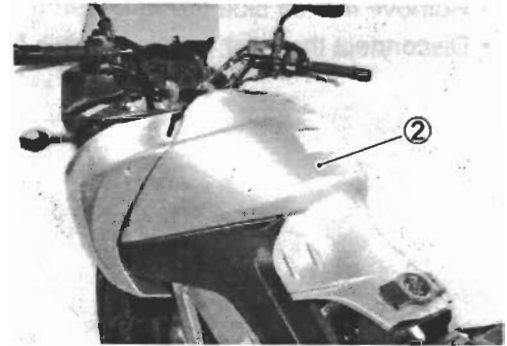

- Disconnect the cooling fan motor and thermo-switch lead wire coupler. (☞6-5)
- Remove the radiator and water hoses. (☞6-5)

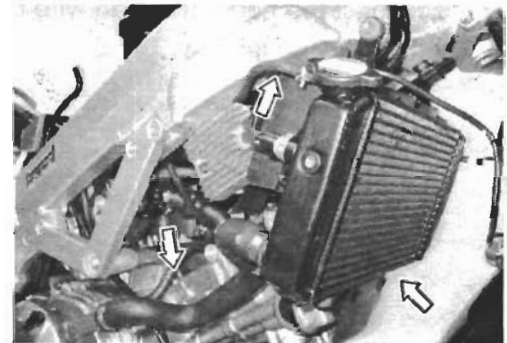

- Remove the air cleaner box ③. (☞5-15)

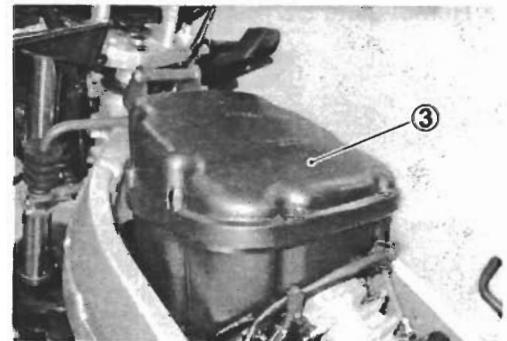

- Remove the throttle body. (☞ 5-16)

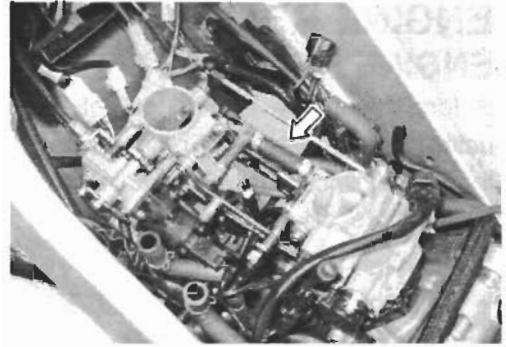

- Disconnect the spark plug caps.

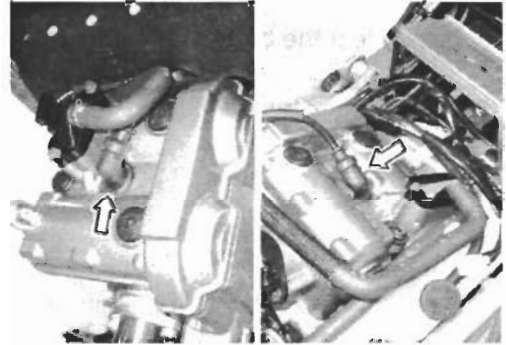

- Remove the left side frame cover. (☞ 7-5)
- Disconnect the gear position switch lead wire coupler ①.

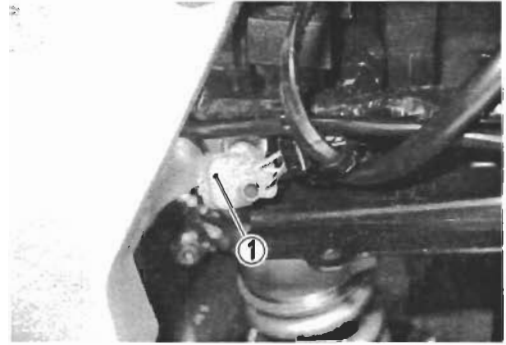

- Disconnect the generator lead wire coupler ② and CKP sensor lead wire coupler ③.

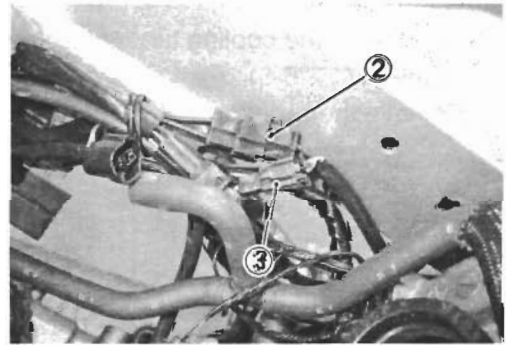

- Remove the ECT sensor lead wire coupler ④.

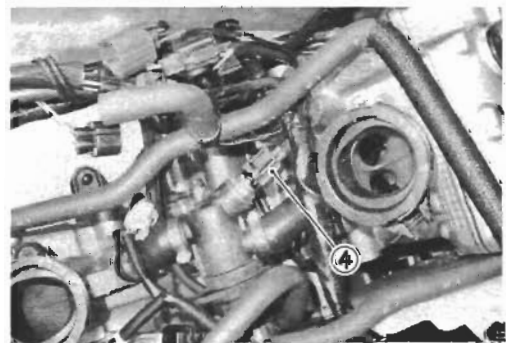

- Remove the gearshift lever ①.
- Remove the engine sprocket cover ②.

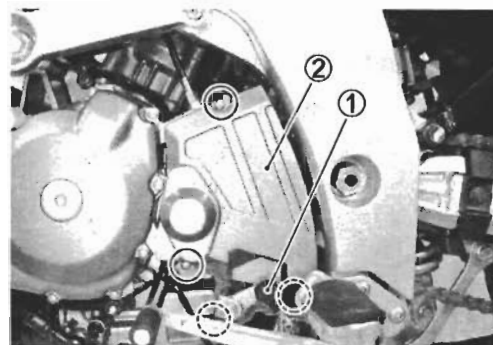

- Remove the clutch release assembly ③, its support plate ④ and spring ⑤.

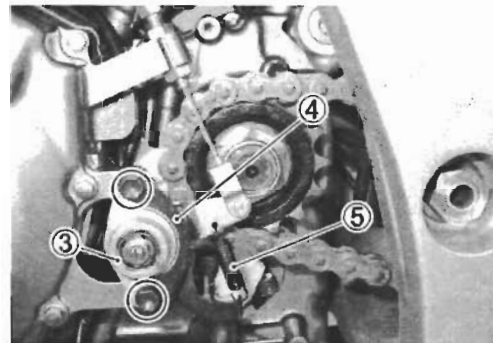

- Remove the clutch push rod ⑥.
- Remove the clutch cable from the generator cover.

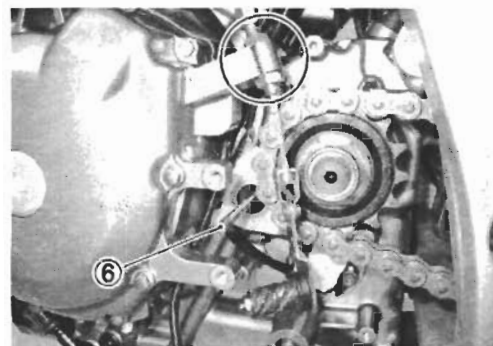

**NOTE:**

*If it is necessary to replace the clutch cable or clutch release lever, pry up and bend down the stopper (A) of the clutch release lever.*

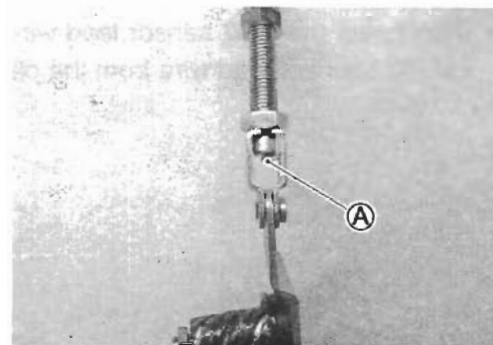

- Flatten the lock washer.
- Remove the engine sprocket nut ⑦ and lock washer while depressing the brake pedal.





- Remove the cotter pin. (For E-03, 28, 33)
- Loosen the rear axle nut ①.
- Loosen the chain adjusters ②.

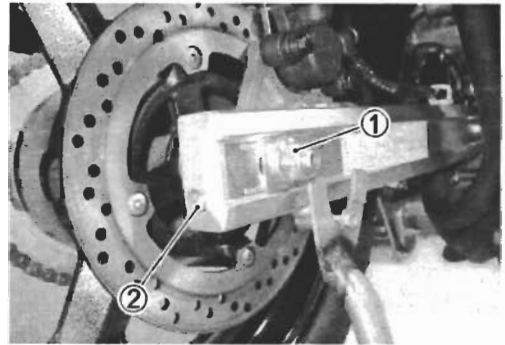

- Remove the engine sprocket ③.



- Disconnect the engine ground lead wire ④.

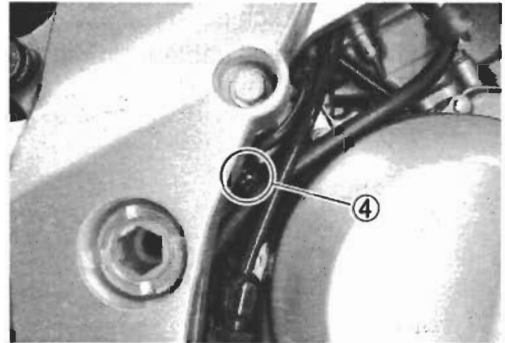

- Disconnect the HO2 sensor lead wire coupler ⑤ and release the HO2 sensor lead wire from the clamp ⑥.

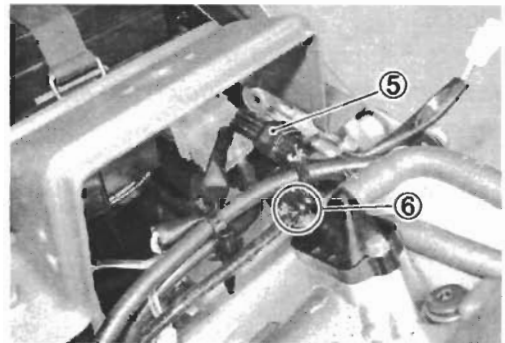

- Remove the muffler mounting bolts.



- Remove the muffler mounting bolt ①.
- Loosen the front exhaust pipe mounting bolts ②.

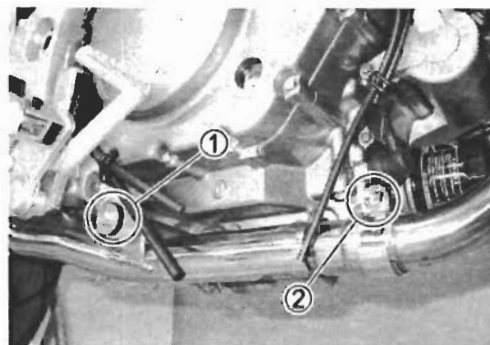

- Remove the front exhaust pipe ③.

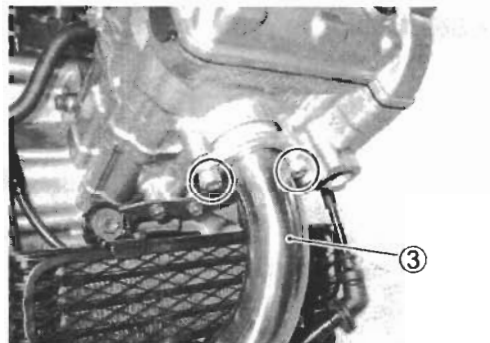

- Loosen the rear exhaust pipe mounting bolts.
- Remove the muffler.



- Remove the right footrest bracket mounting bolts.

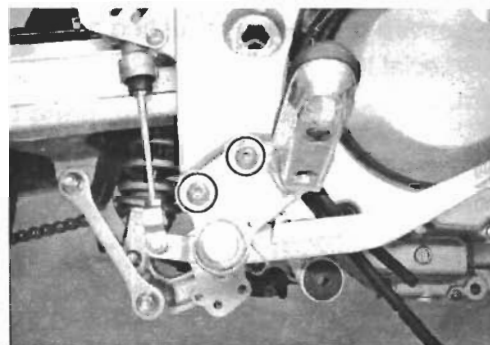

- Remove the oil cooler ④.

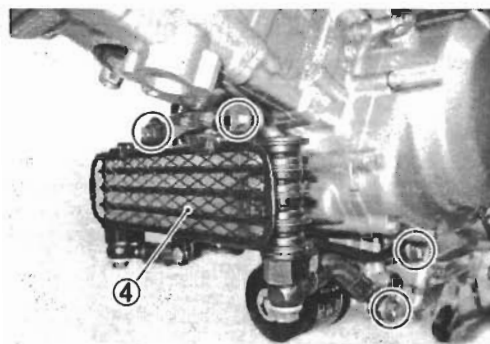

- Disconnect the starter motor lead wire ① and oil pressure switch lead wire ②.

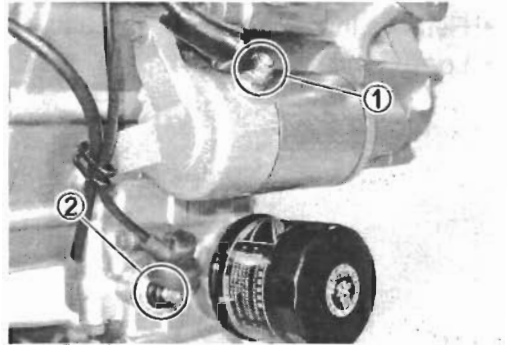

- Support the engine with an engine jack.

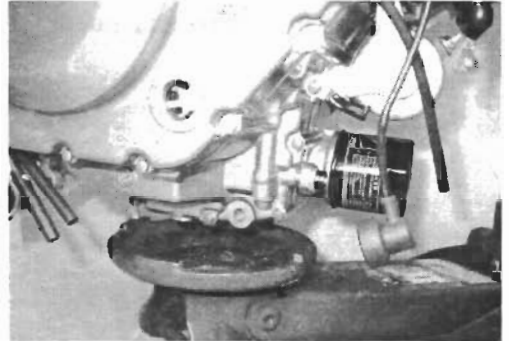

- Remove the engine mounting nut ③ and bolt ④.

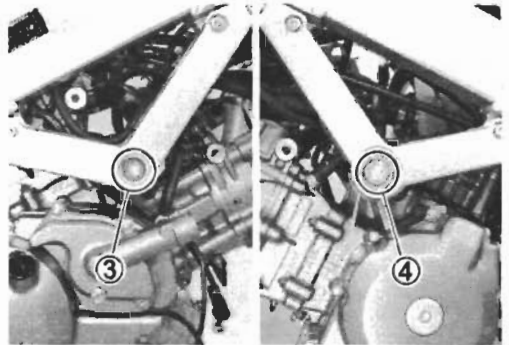

- Loosen the engine mounting thrust adjuster lock-nut with the special tool.

 **09940-14990: Engine mounting thrust adjuster socket wrench**

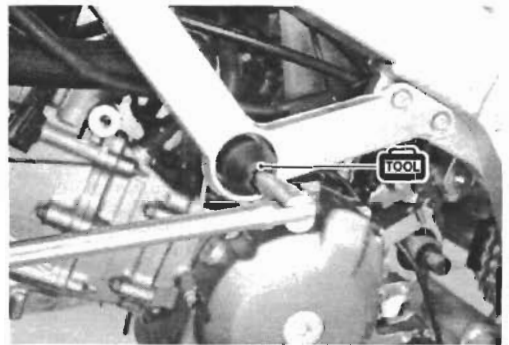

- Loosen the engine mounting thrust adjuster.

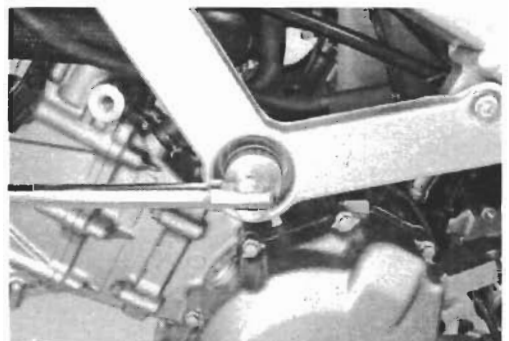

- Remove the left engine mounting bracket ①.

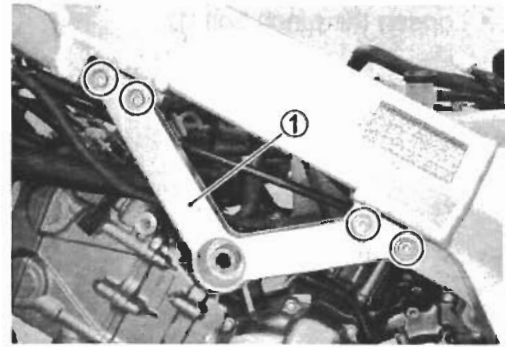

- Disconnect the ignition coil lead wires ②.
- Disconnect the water hose clamp ③.

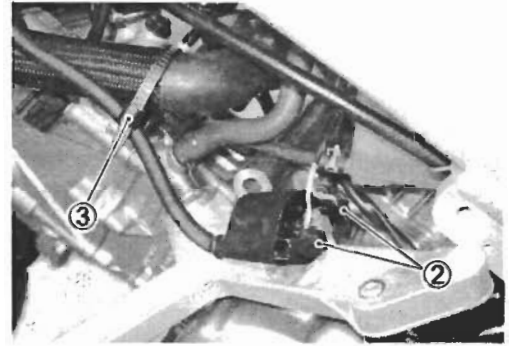

- Remove the engine mounting nut.

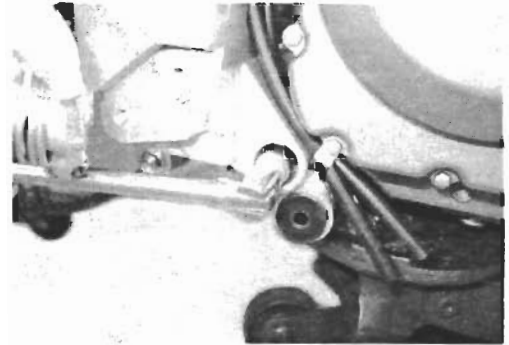

- Loosen the engine mounting thrust adjuster lock-nut.

 **09940-14990: Engine mounting thrust adjuster socket wrench**

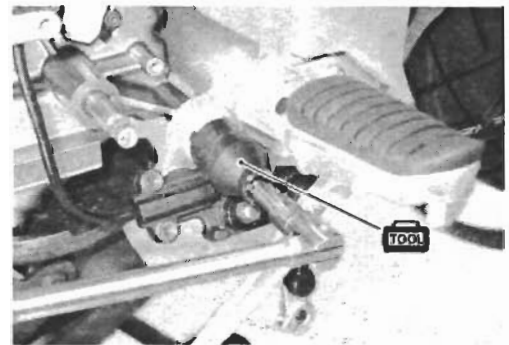

- Loosen the engine mounting thrust adjuster.

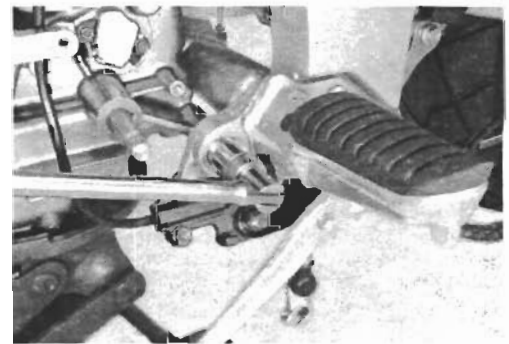

- Loosen the pinch bolt ①.

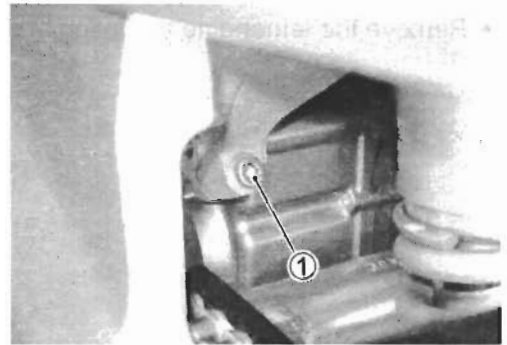

- Gradually lower the engine assembly by removing the bolt ②, ③.

**CAUTION**

Be careful not to damage the frame and engine when removing the engine from the frame.

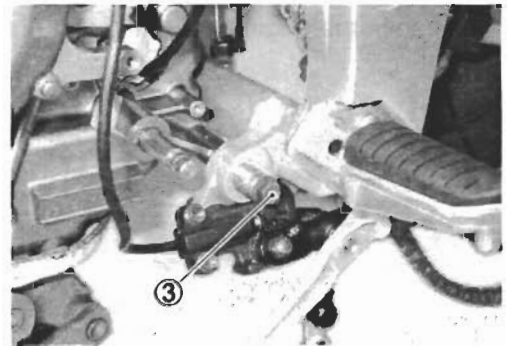
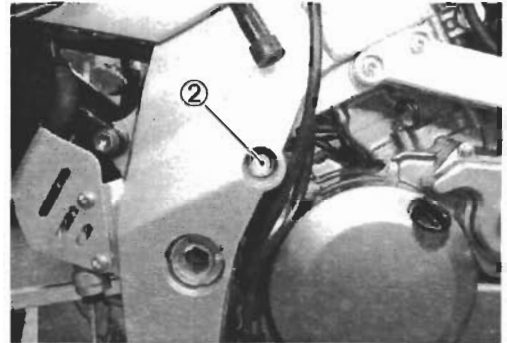

## ENGINE INSTALLATION

Remount the engine in the reverse order of engine removal.

Pay attention to the following points:

**NOTE:**

\* The engine mounting nuts are self-locking.

\* Once the nut has been removed, it is no longer of any use. Be sure to use new nuts, and then tighten them to the specified torque.

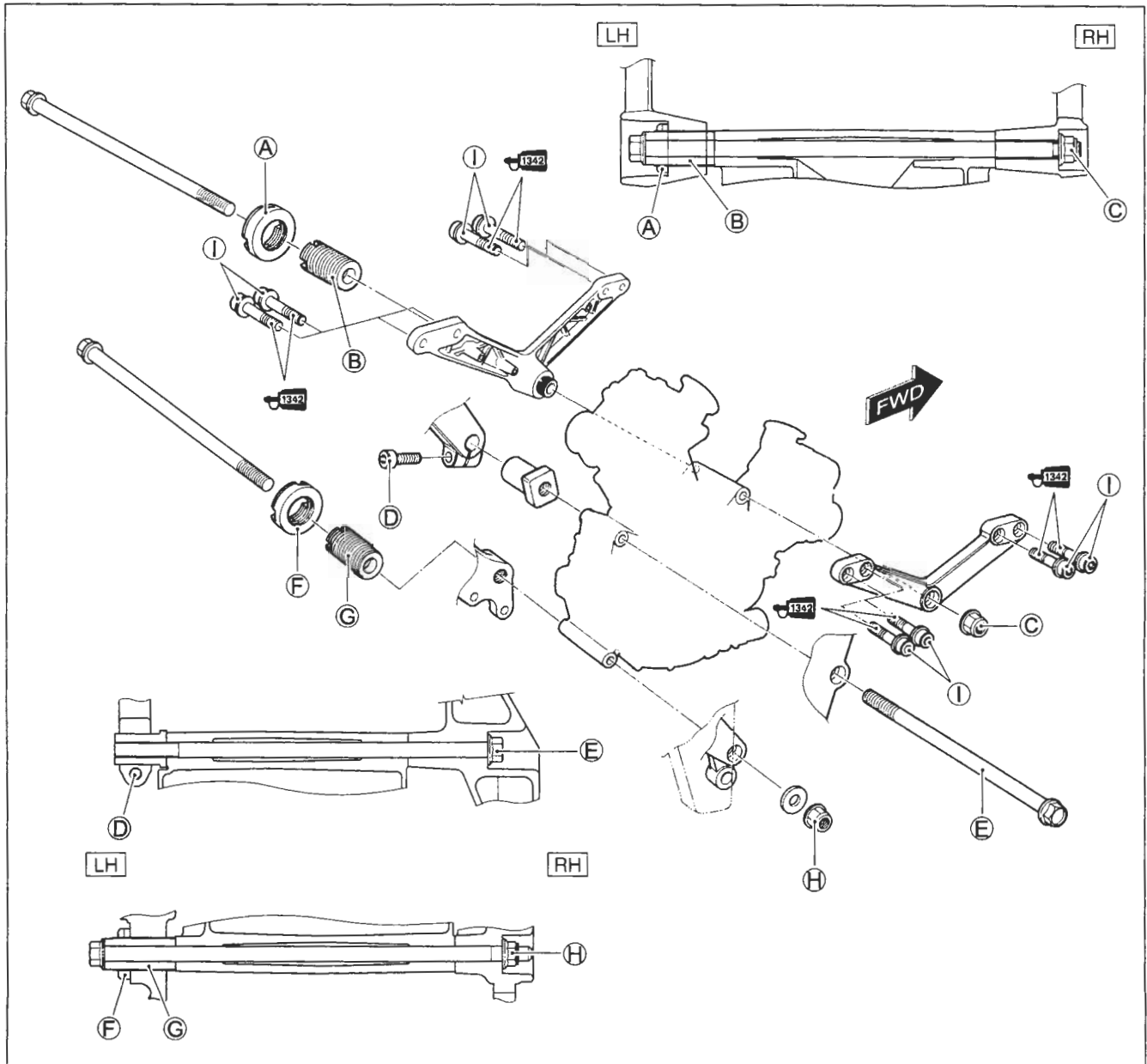

ITEM	N·m	kgf·m	lb·ft
ⒶⒻ	45	4.5	32.5
ⒷⒼ	12	1.2	8.5
Ⓒ	93	9.3	67.5
Ⓓ	25	2.5	18.0
ⒺⒻ	55	5.5	40.0
Ⓖ	35	3.5	25.5

- Before installing the engine assembly, install the spacer (A), collar (B) and engine thrust adjuster (C).

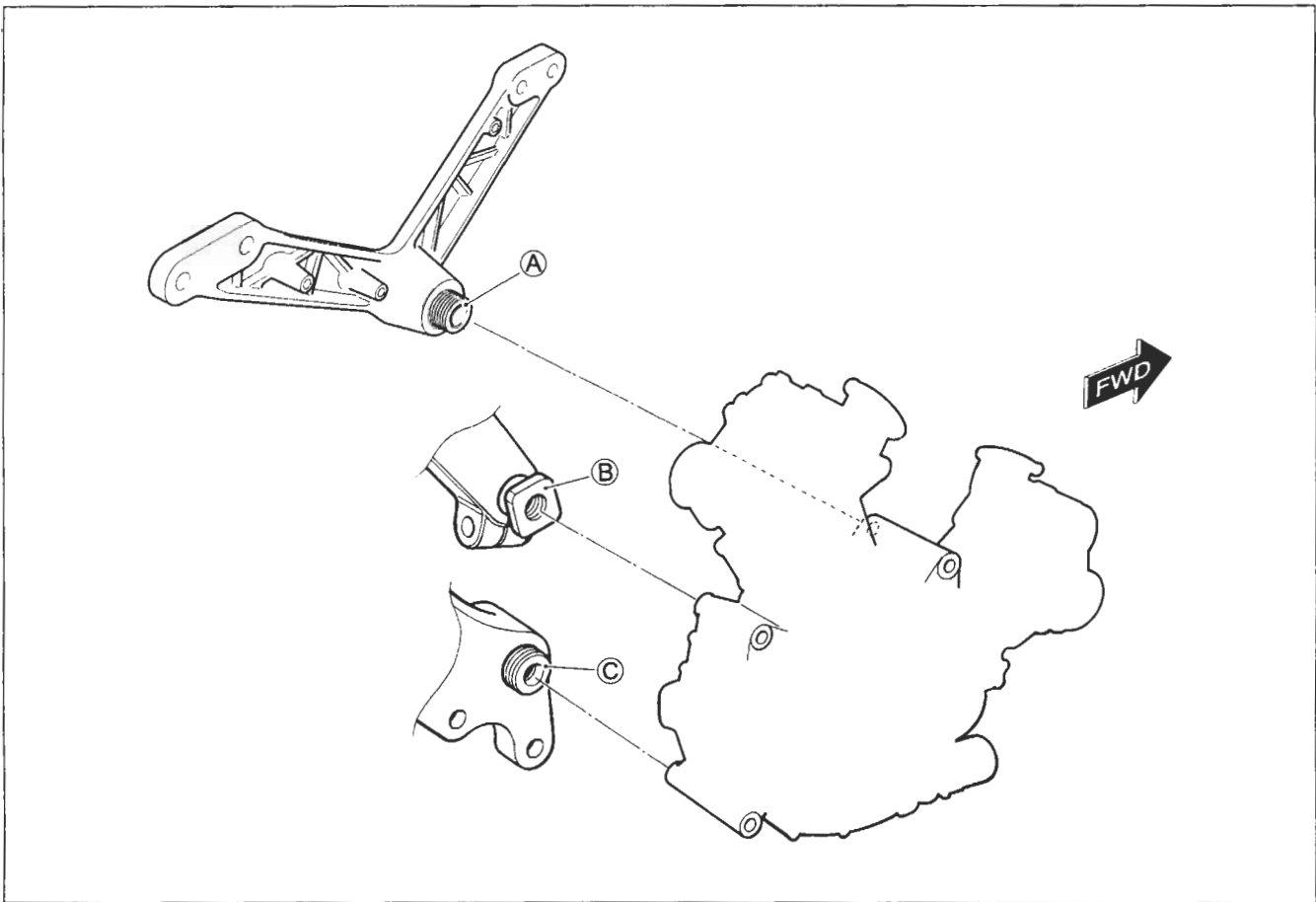

- Install the collar (1) onto the crankcase properly as shown.

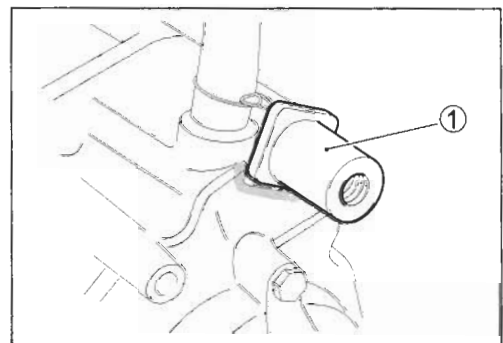

- Install the left engine mounting bracket (2).
- Apply THREAD LOCK to the engine mounting bracket bolts.
- Tighten the engine mounting bracket bolts to the specified torque.

 **Engine mounting bracket bolt:**  
 35 N-m (3.5 kgf-m, 25.5 lb-ft)

 **99000-32050: THREAD LOCK "1342"**

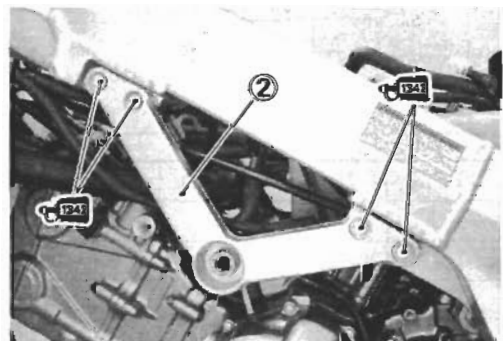

- Put the drive chain on the driveshaft.

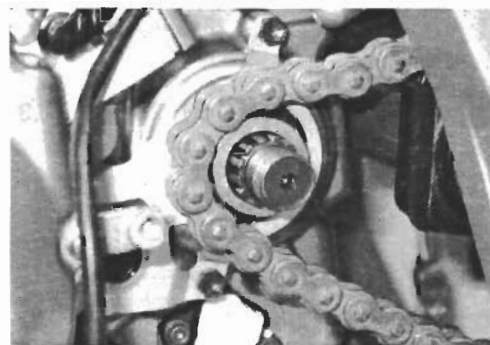

- Gradually raise the engine assembly and align all the bolt holes.
- Install the engine mounting bolts and tighten them temporarily.
- Tighten the engine mounting thrust adjusters to the specified torque.

 **Engine mounting thrust adjuster:**  
12 N·m (1.2 kgf-m, 8.5 lb-ft)





- Tighten the engine mounting thrust adjuster lock-nuts to the specified torque with the special tool.

 **09940-14990: Engine mounting thrust adjuster socket wrench**

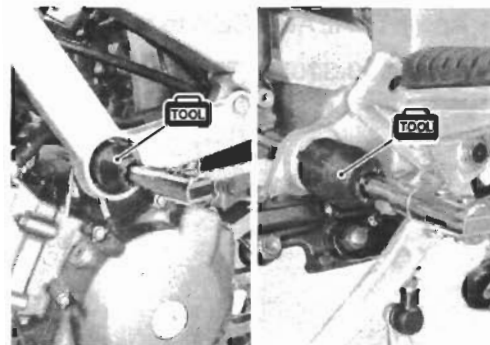
 **Engine mounting thrust adjuster lock-nut:**  
45 N·m (4.5 kgf-m, 32.5 lb-ft)



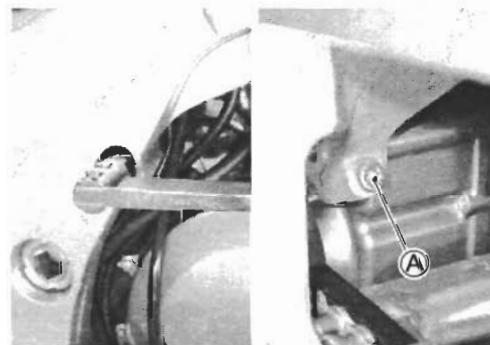

- After tightening the engine mounting bolt, tighten the pinch bolt .

 **Engine mounting bolt: 55 N·m (5.5 kgf-m, 40.0 lb-ft)**  
**Engine mounting pinch bolt :**  
25 N·m (2.5 kgf-m, 18.0 lb-ft)



- Tighten the engine mounting nuts to the specified torque.

 **Engine mounting nut : 93 N·m (9.3 kgf-m, 67.5 lb-ft)**  
**Engine mounting nut: 55 N·m (5.5 kgf-m, 40.0 lb-ft)**

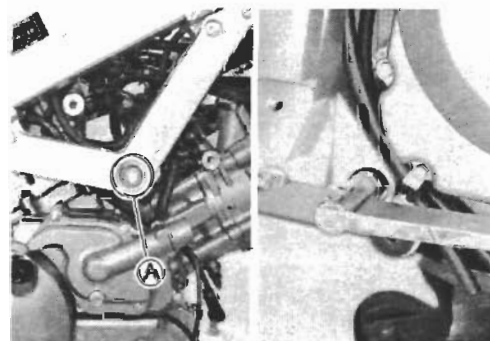



- Install the washers and tighten the union bolt to the specified torque.

 Oil cooler union bolt: 23 N-m (2.3 kgf-m, 16.5 lb-ft)

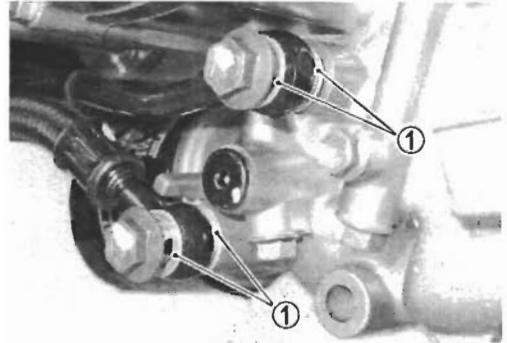

- Install the new gaskets.

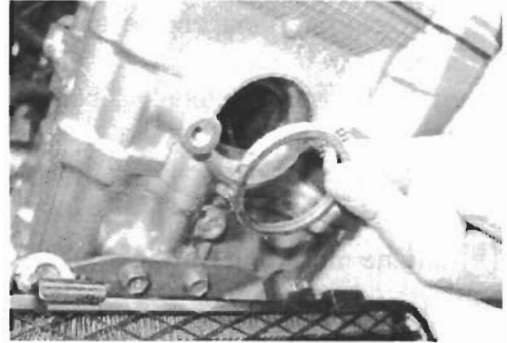

- Apply THREAD LOCK to the muffler mounting bolt.

 **1342** 99000-32050: THREAD LOCK "1342"

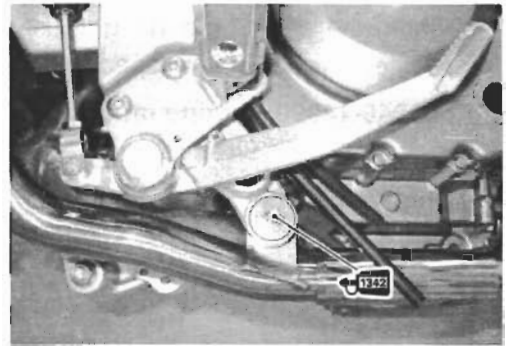

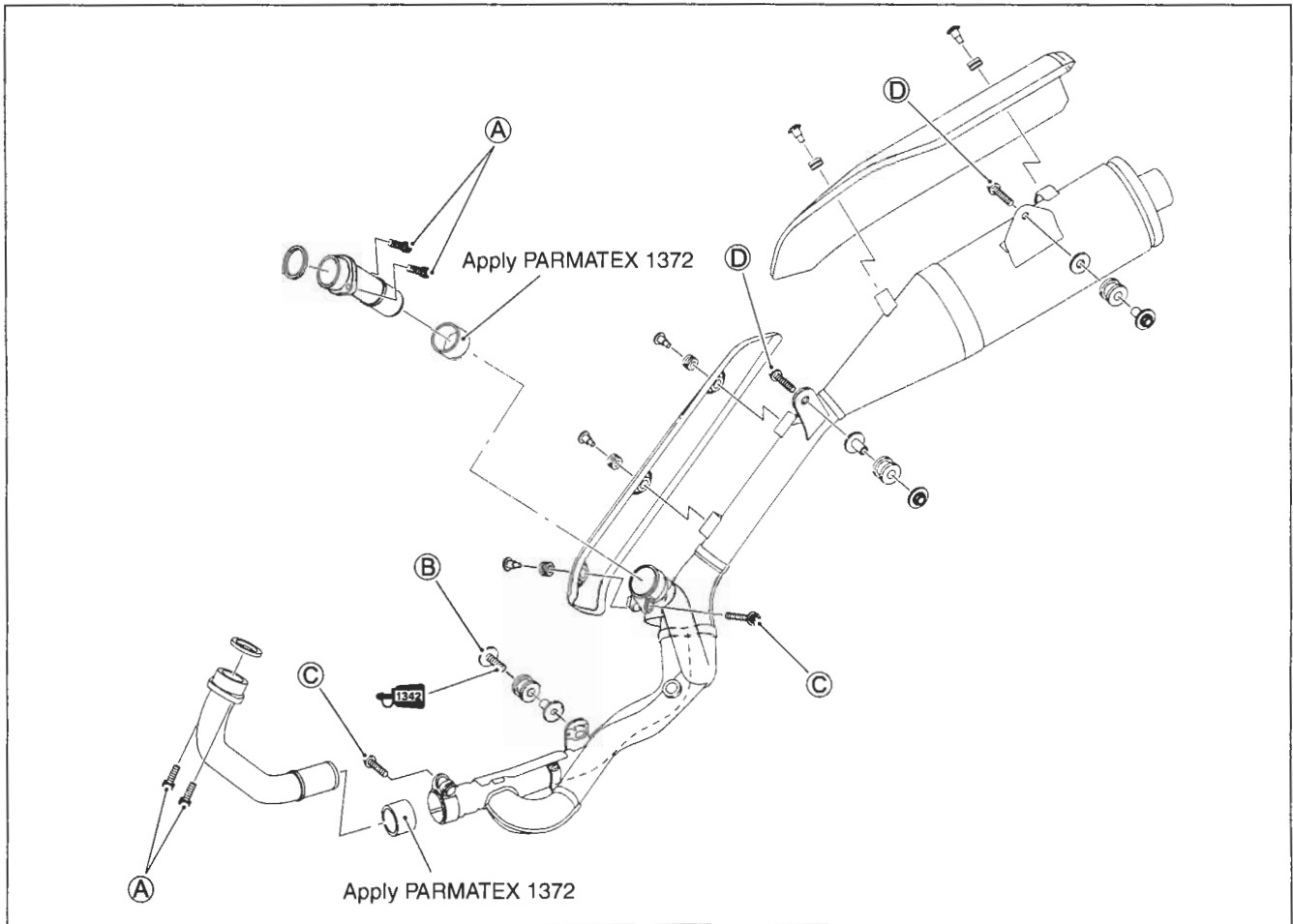

ITEM	N-m	kgf-m	lb-ft
Ⓐ Ⓑ Ⓒ Ⓓ	23	2.3	16.5

- Adjust the brake pedal height.

**DATA** Brake pedal height Ⓐ  
 Standard: 20 – 30 mm (0.79 – 1.18 in)

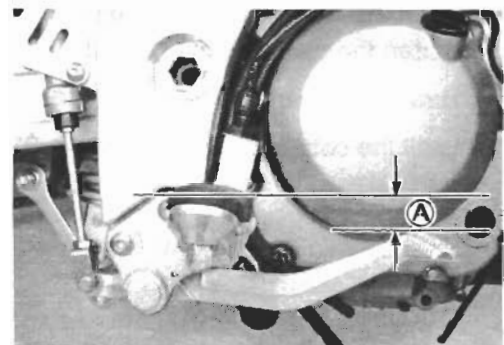

- Install the gearshift arm as shown.

**DATA** Gearshift arm angle Ⓐ: Approx. 63.6°

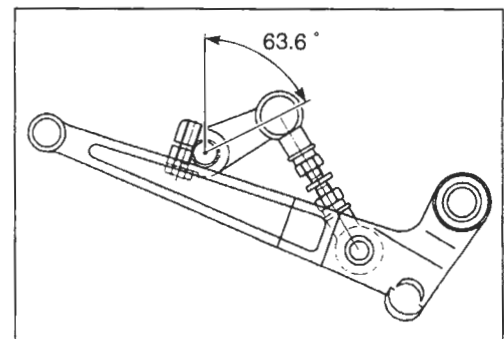

- Adjust the gearshift lever as shown.

**DATA** Gearshift lever height **A**  
 Standard: 20 – 30 mm (0.79 – 1.18 in)

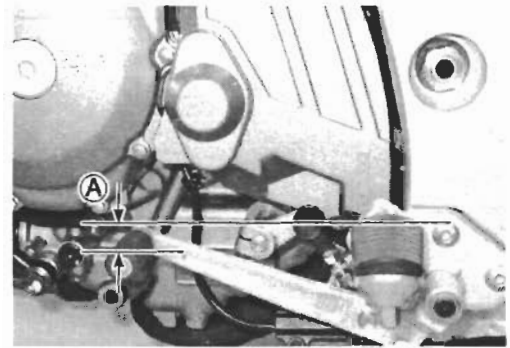

- Install the engine sprocket.



- Install the engine sprocket and the washer.
- Apply a small quantity of THREAD LOCK to the drive shaft thread portion.

**1342** 99000-32050: THREAD LOCK “1342”

- Tighten the engine sprocket nut **1** to the specified torque.

**Engine sprocket nut: 145 N·m (14.5 kgf·m, 105 lb·ft)**

- Bend the lock washer.

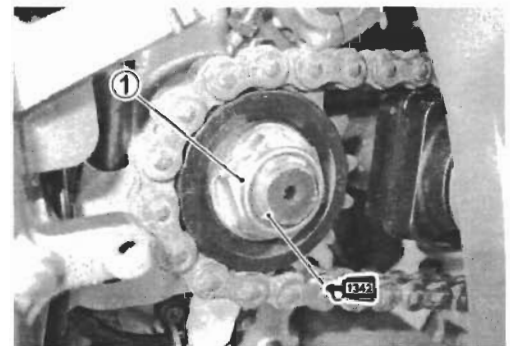

- Adjust the drive chain slack. (☞ 2-21)
- Tighten the rear axle nut **2** to the specified torque.

**Rear axle nut: 100 N·m (10.0 kgf·m, 72.5 lb·ft)**

- Install the cotter pin. (For E-03, 28, 33)

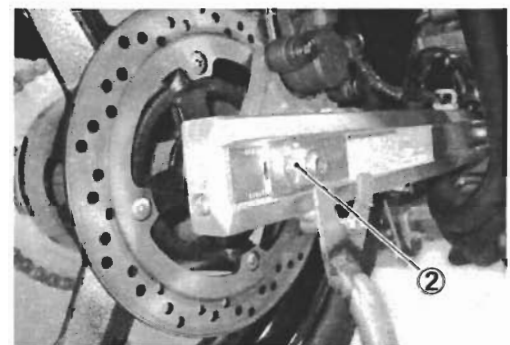

- Apply SUZUKI SUPER GREASE to the clutch push rod and install it.

**TAH** 99000-25030: SUZUKI SUPER GREASE “A” (USA)  
 99000-25010: SUZUKI SUPER GREASE “A” (Others)

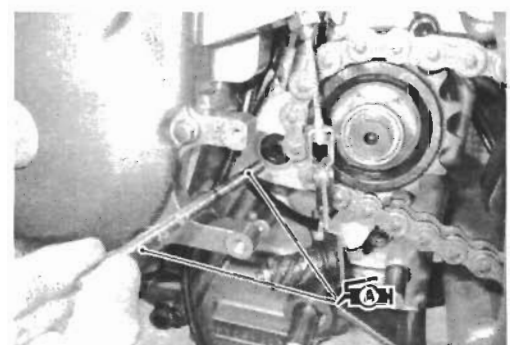

- Install the clutch cable to the generator cover temporarily.



- Apply SUZUKI MOLY PASTE to the clutch release.

 99000-25140: SUZUKI MOLY PASTE

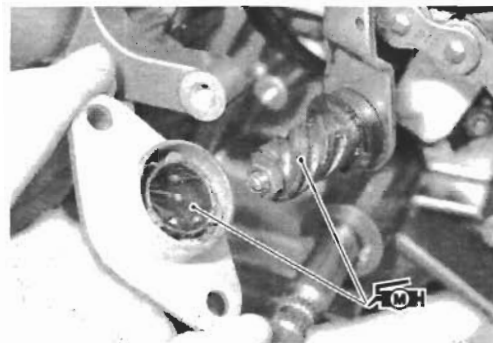

- Assemble the clutch release so that the lever arm (A) will be angle of 80 degree with axle (B).
- Adjust the clutch cable play. (☞ 2-17)

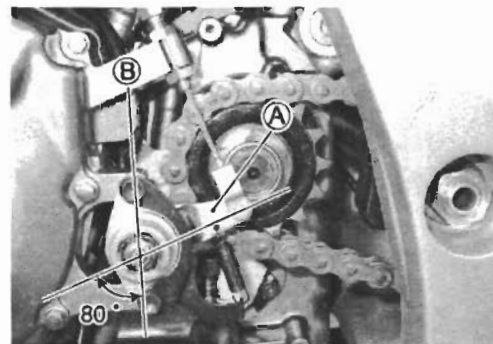

**NOTE:**

*After installing the clutch release, make sure that there is clearance between the clutch cable end and the driveshaft end.*

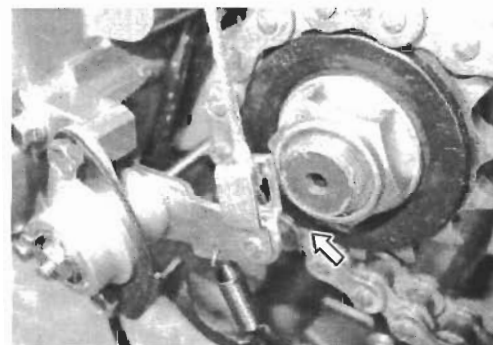

- After installing the engine, route the wire harness, cables and hoses properly. (☞ 9-16)
- Adjust the following items.
  - \* Engine oil (☞ 2-14)
  - \* Engine coolant (☞ 2-19)
  - \* Engine idle speed (☞ 2-15)
  - \* Throttle cable play (☞ 2-15)
  - \* Clutch cable play (☞ 2-17)
  - \* Throttle body synchronization (☞ 5-32)

## ENGINE DISASSEMBLY

### ENGINE TOP SIDE

#### CAUTION

Identify the position of each removed part. Organize the parts in their respective groups (e.g., intake, exhaust) so that they can be reinstalled in their original positions.

- Remove the spark plugs. (☞ 2-6)
- Disconnect the crankcase breather hoses ①.
- Disconnect the PAIR hoses ②.

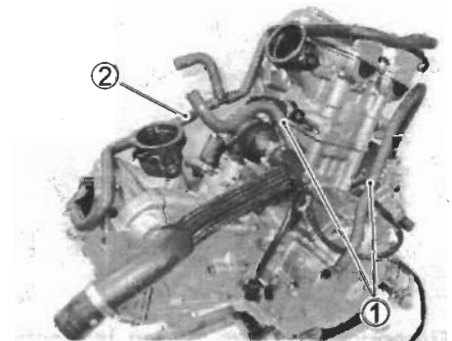

- Remove the thermostat case ③ along with the hoses ④.

#### NOTE:

Refer to the section 6 for their servicing.

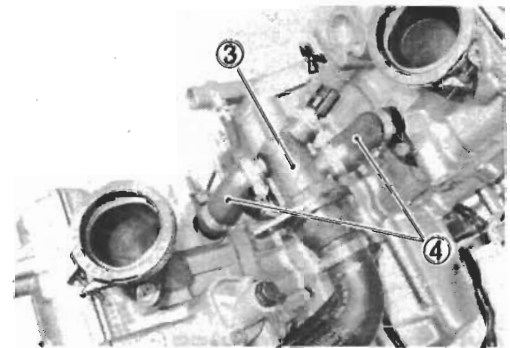

- Remove the water unions ⑤ and intake pipes ⑥.

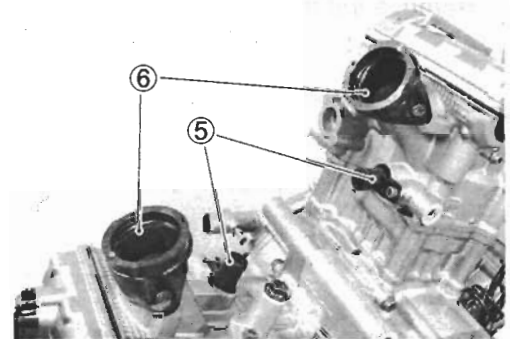

- Remove the oil cooler bracket ⑦.

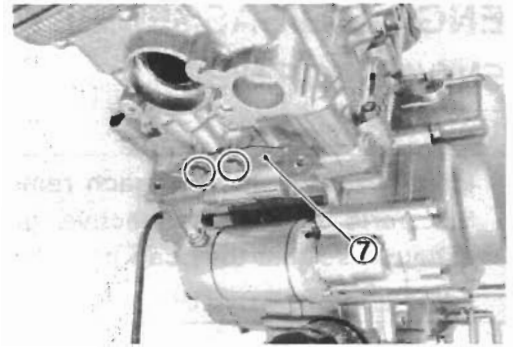

- Remove the rear exhaust pipe ⑧ and gasket.

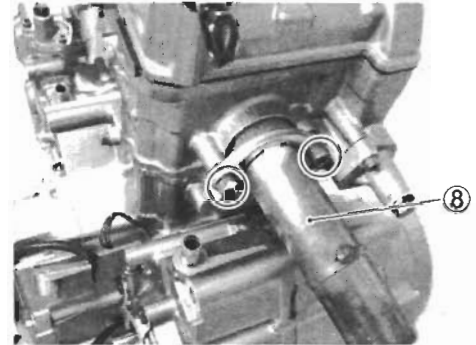

- Remove the valve timing inspection plug ⑨ and generator cover plug ⑩.

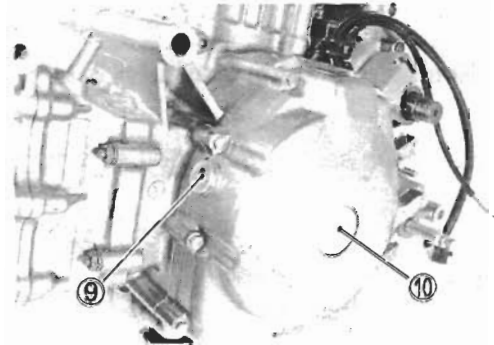

### CYLINDER HEAD COVER

- Remove the front cylinder head cover ①.

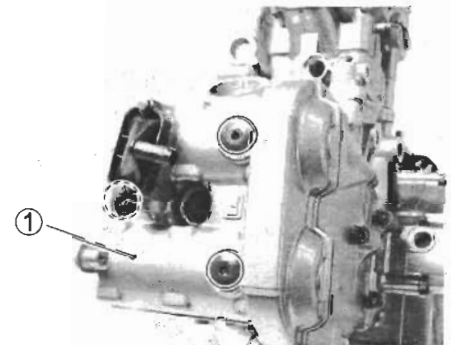

- Remove the dowel pin ② and O-ring ③.

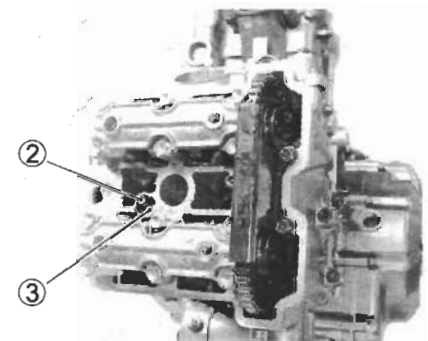

- Remove the rear cylinder head cover ④.

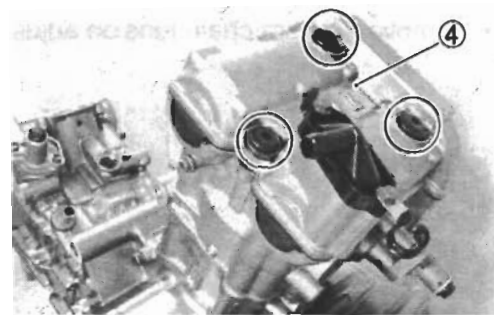

- Remove the dowel pin ⑤ and O-ring ⑥.



#### FRONT CAMSHAFTS

- Turn the crankshaft to bring the “| F” line ① on generator rotor to the index mark ② of the valve inspection hole and also to bring the cams to the position as shown in illustration.

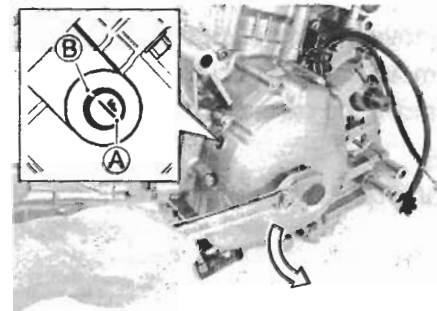

#### NOTE:

\* At the above condition, the front cylinder is at TDC of compression stroke.

\* Before removing the camshafts, inspect the valve clearance. (F 2-8)

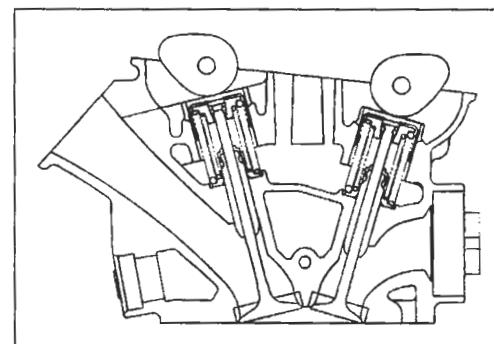

- Remove the cam chain guide ①.

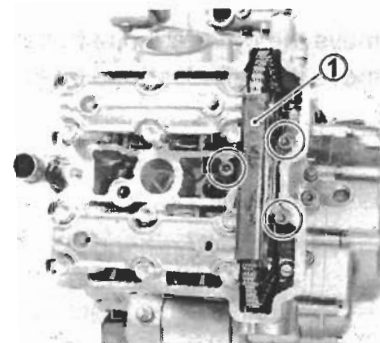



- Remove the spring holder bolt ②, spring and gasket.
- Remove the cam chain tension adjuster ③.

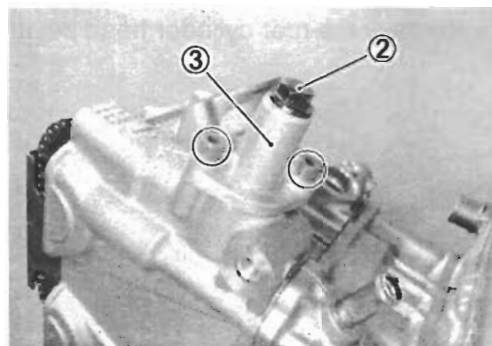

- Remove the intake camshaft journal holder ④.
- Remove the exhaust camshaft journal holder ⑤.

**NOTE:**

Mark the cylinder location as "F" to the camshaft journal holders.

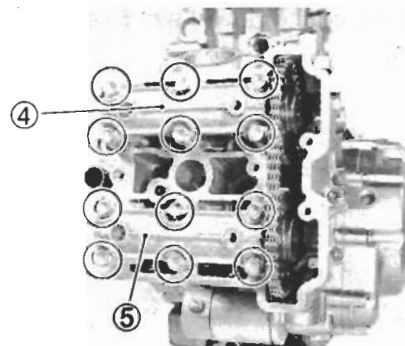

- Remove the dowel pins ⑥.
- Remove the intake camshaft ⑦.
- Remove the exhaust camshaft ⑧.

**NOTE:**

Do not drop the dowel pins into the crankcase.

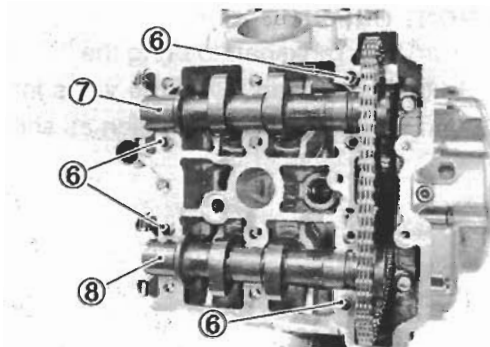

**FRONT CYLINDER HEAD**

- Remove the cylinder head bolt (M6) ①.

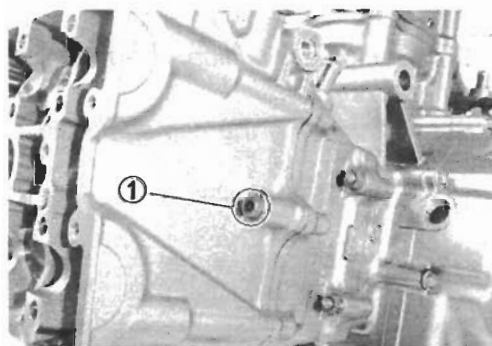

- Remove the cylinder head bolts (M6) ②.
- Remove the cylinder head bolts ③ and washers.

**NOTE:**

When loosening the cylinder head bolts, loosen each bolt little by little diagonally.

- Remove the cylinder head ④.

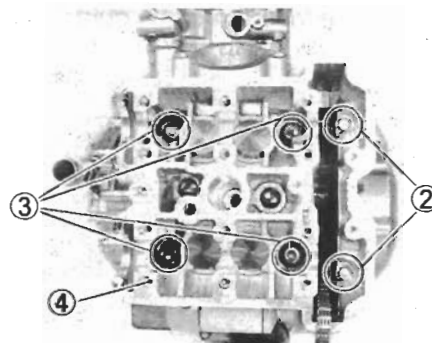

- Remove the cylinder head gasket ⑤, dowel pins ⑥ and cam chain guide ⑦.

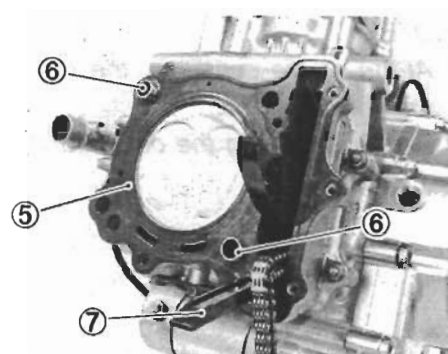

### FRONT CYLINDER

- Remove the cylinder nuts ①.
- Remove the cylinder ②.

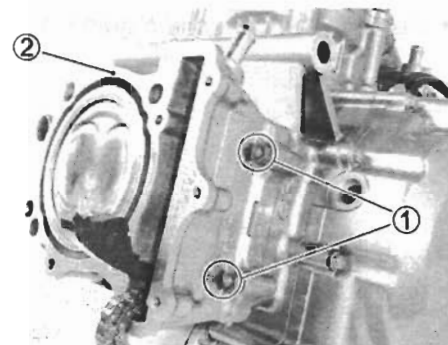

- Remove the cylinder base gasket ③ and dowel pins ④.

### NOTE:

*Make sure that the oil jet is inserted in the crankcase.*

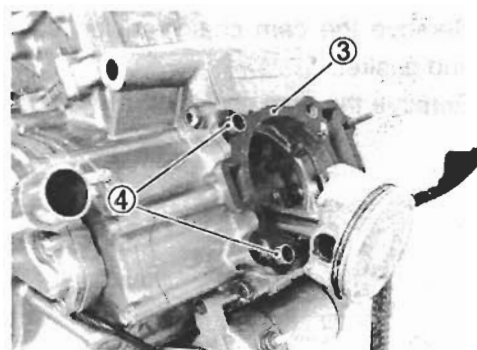

### FRONT PISTON

- Place a clean rag over the cylinder base so as not to drop the piston pin circlip into the crankcase.
- Remove the piston pin circlip ①.
- Remove the piston ② by driving out the piston pin.

### NOTE:

*Scribe the cylinder number on the head of the piston.*

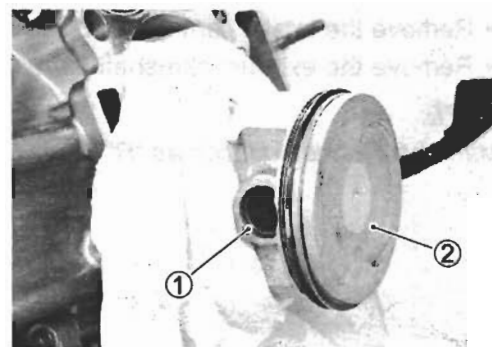

### REAR CAMSHAFTS

- Rotate the generator 360 degrees (1 turn) counterclockwise and align the "F" line ① on the generator rotor with the index mark ② of the valve timing inspection hole.

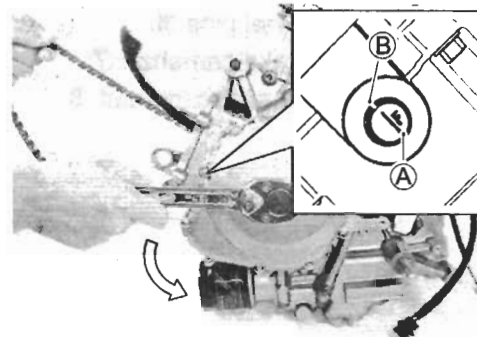

**NOTE:**

\* At the above condition, the rear cylinder is at ATDC 90 ° on expansion stroke.

\* Before removing the camshafts, inspect the valve clearance. (↖ 2-8)

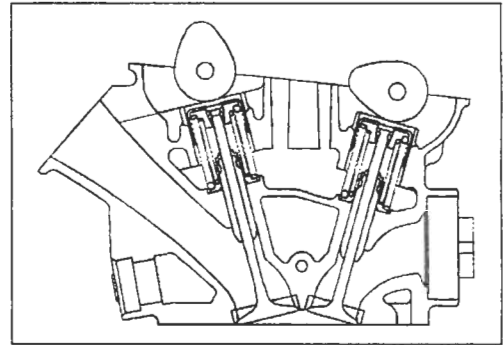

- Remove the cam chain guide ①.

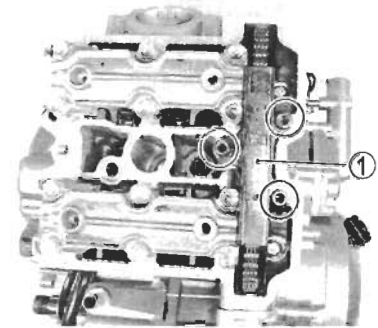

- Remove the cam chain tension adjuster cap bolt ②, spring and gasket.
- Remove the cam chain tension adjuster ③.

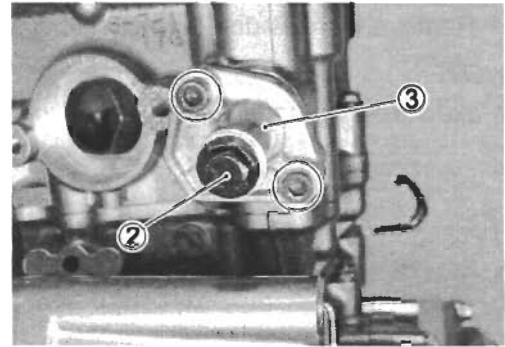

- Remove the intake camshaft journal holder ④.
- Remove the exhaust camshaft journal holder ⑤.

**NOTE:**

Mark the cylinder location as "R" to the camshaft journal holders.

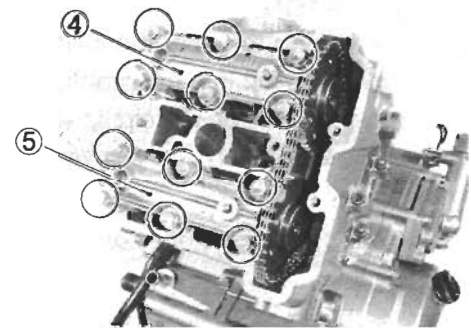

- Remove the dowel pins ⑥.
- Remove the intake camshaft ⑦.
- Remove the exhaust camshaft ⑧.

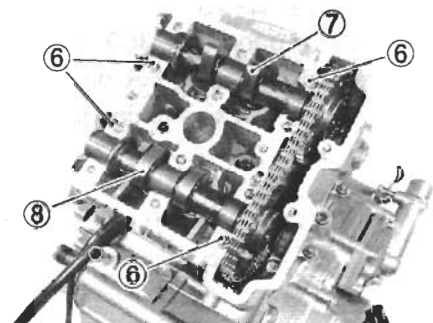

**REAR CYLINDER HEAD**

- Remove the cylinder head bolt (M6) ①.

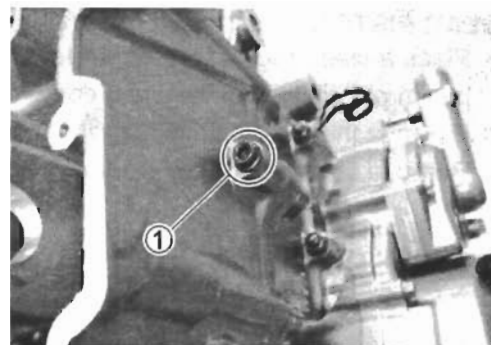

- Remove the cylinder bolts (M6) ②.
- Remove the cylinder head bolts ③ and washers.

**NOTE:**

*When loosening the cylinder head bolts, loosen each bolt little by little diagonally.*

- Remove the cylinder head ④.

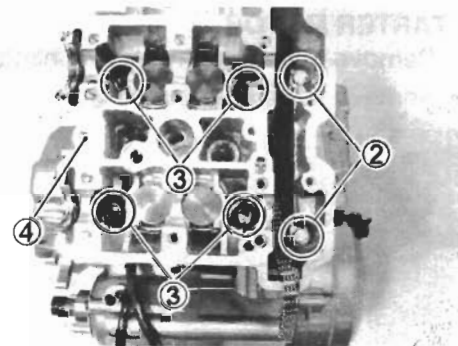

- Remove the cylinder head gasket ⑤, dowel pins ⑥ and cam chain guide ⑦.

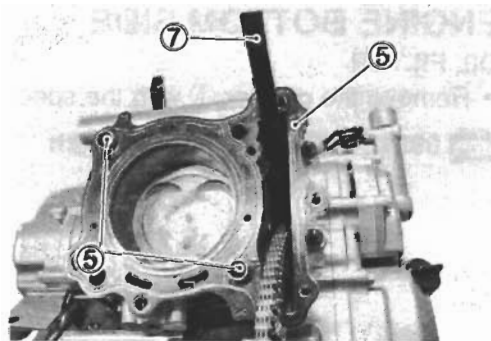
**REAR CYLINDER**

- Remove the cylinder nuts ① and clamp.
- Remove the cylinder ②.

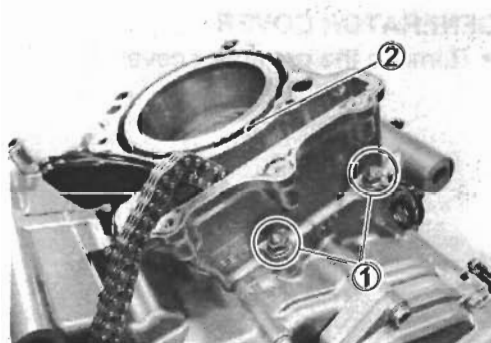

- Remove the cylinder base gasket ③ and dowel pins ④.

**NOTE:**

*Make sure that the oil jet ⑤ is inserted in the crankcase.*

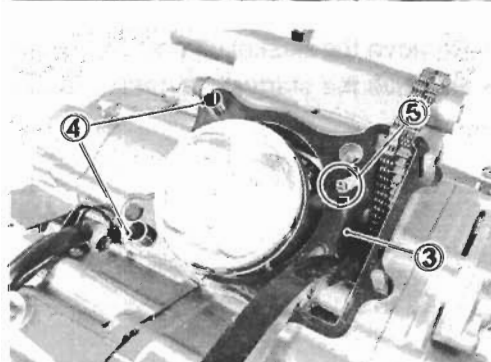

**REAR PISTON**

- Place a clean rag over the cylinder base so as not to drop the piston pin circlip into the crankcase.
- Remove the piston pin circlip ①.
- Remove the piston ② by driving out the piston pin.

**NOTE:**

*Scribe the cylinder number on the head of the piston.*

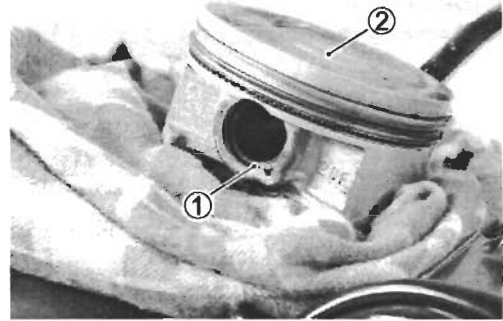

**STARTER MOTOR**

- Remove the starter motor mounting bolts and the clamp ①.
- Remove the starter motor ②.

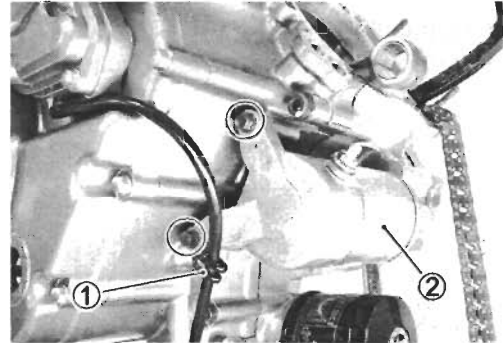

**ENGINE BOTTOM SIDE**

**OIL FILTER**

- Remove the oil filter ① with the special tool.

**TOOL** 09915-40610: Oil filter wrench

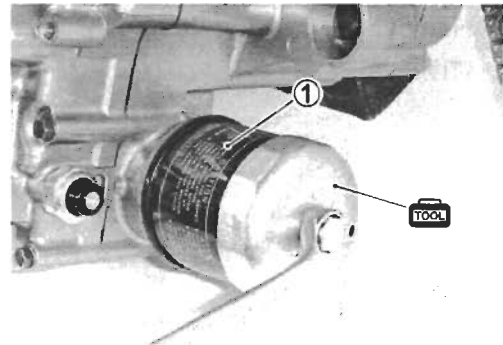

**GENERATOR COVER**

- Remove the generator cover ①.

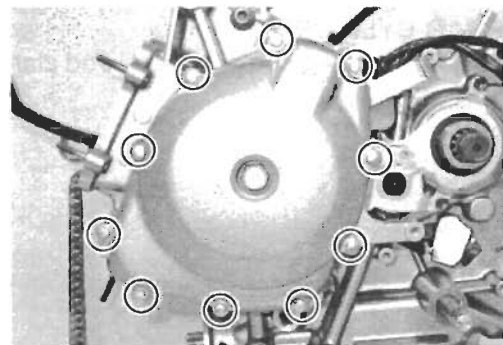

- Remove the gasket ② and dowel pins ③.
- Remove the starter idle gear ④ and its shaft ⑤.

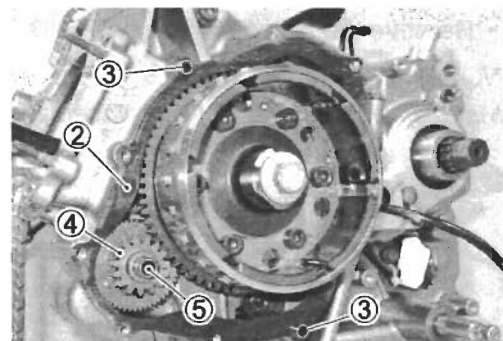

**CLUTCH COVER**

- Remove the clutch cover ①.

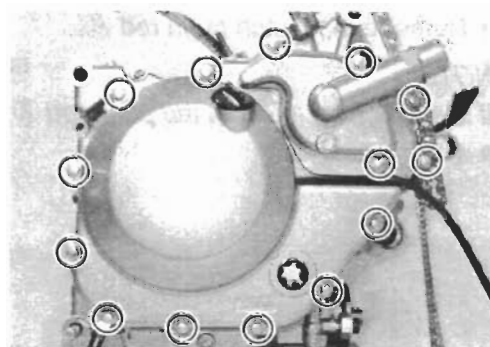

- Remove the dowel pins ② and gasket ③.

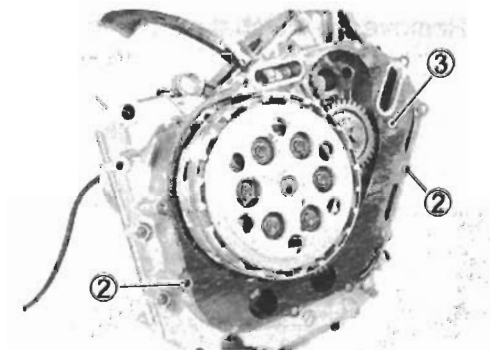
**CLUTCH**

- Hold the generator rotor ① with the special tool.

 09930-44530: Rotor holder

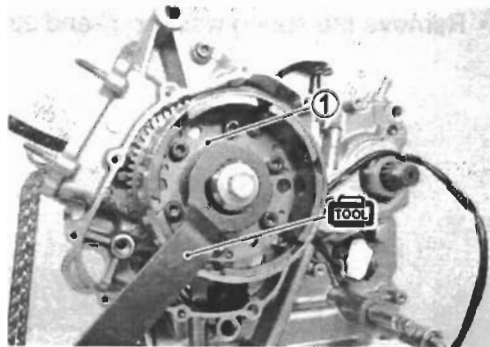

- Remove the clutch springs.

**NOTE:**

*Loosen the clutch spring set bolts little by little and diagonally.*

- Remove the pressure plate ②.

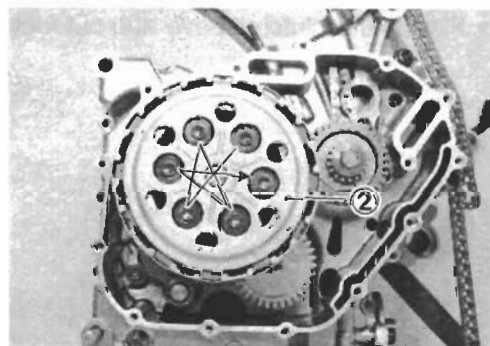

- Remove the clutch push piece ③, the bearing ④ and thrust washer ⑤.

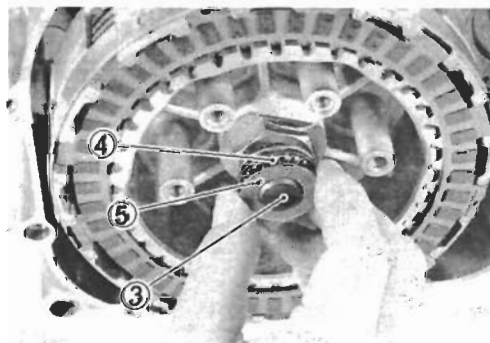

- Remove the clutch push rod ⑥.

**NOTE:**

*If it is difficult to pull out the push rod ⑥, use a magnetic hand or a wire.*

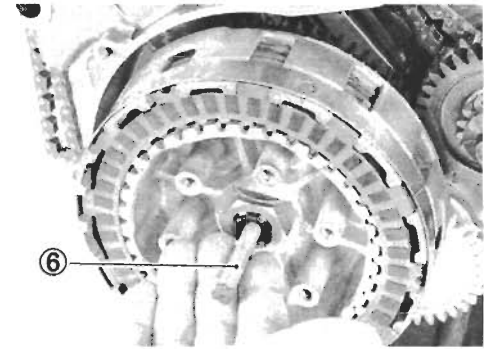

- Remove the clutch drive plates and driven plates.

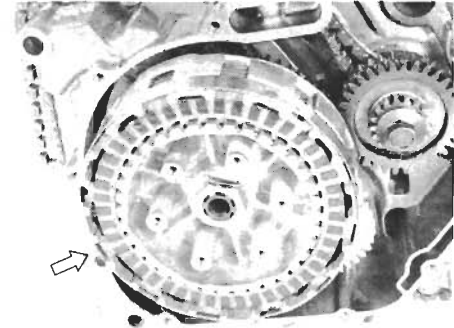

- Remove the spring washer ⑦ and spring washer seat ⑧.

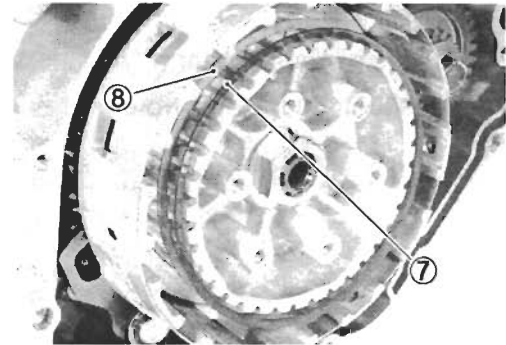

- Flatten the clutch sleeve hub nut lock washer.

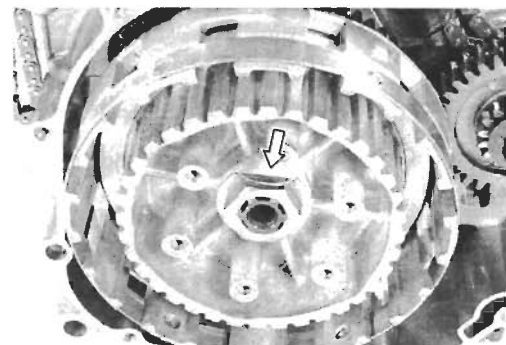

- Hold the clutch sleeve hub with the special tool.

**TOOL 09920-53740: Clutch sleeve hub holder**

- Remove the clutch sleeve hub nut.

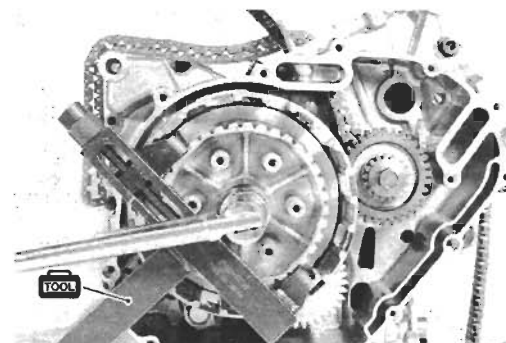

- Remove the lock washer ⑨.
- Remove the clutch sleeve hub ⑩.

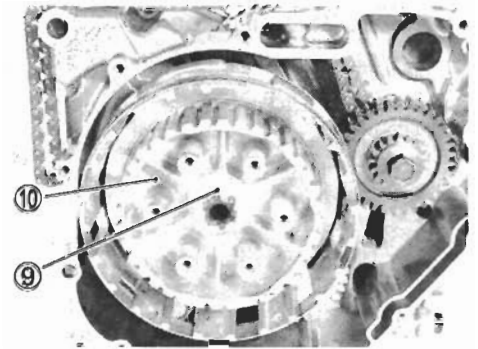

- Remove the thrust washer ⑪.
- Remove the primary driven gear assembly ⑫.

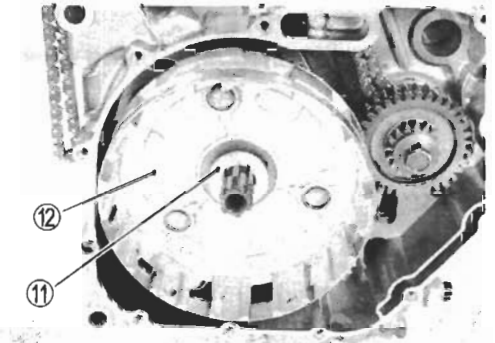

- Remove the spacer ⑬.

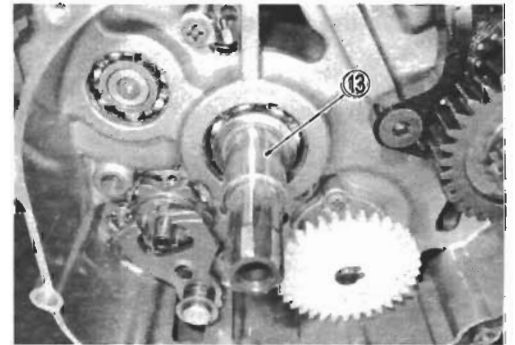

#### OIL PUMP

- Remove the snap ring ①.
- Remove the oil pump driven gear ②.

#### NOTE:

*Do not drop the snap ring ① into the crankcase.*

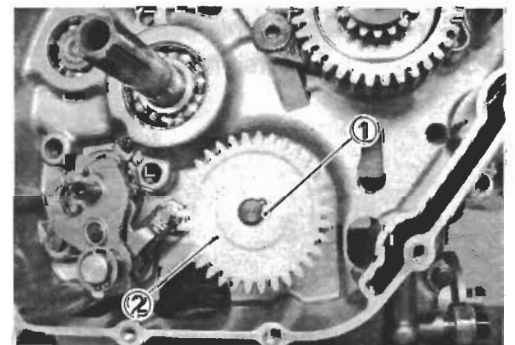

- Remove the pin ③ and the washer ④.

#### NOTE:

*Do not drop the pin ③ and washer ④ into the crankcase.*

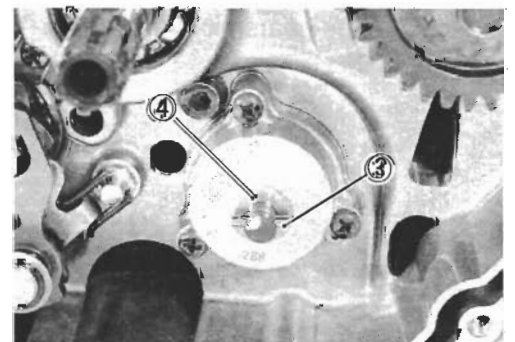



- Remove the oil pump ⑤.

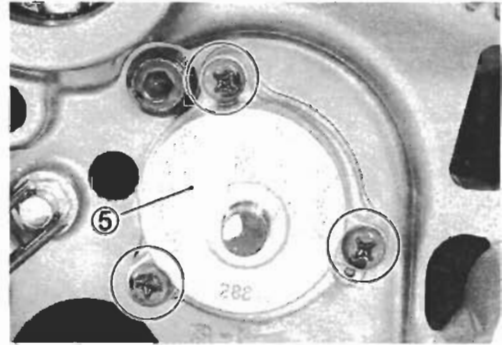

**GEARSHIFT SYSTEM**

- Remove the snap ring ① and washer ②.

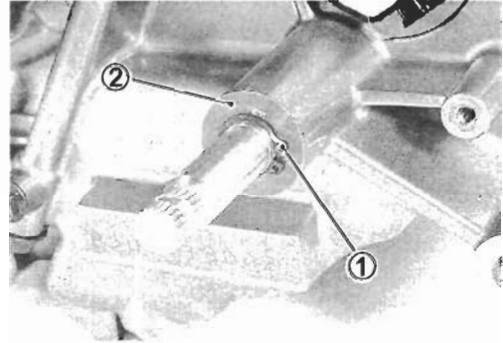

- Remove the gearshift shaft assembly ③ and washer ④.

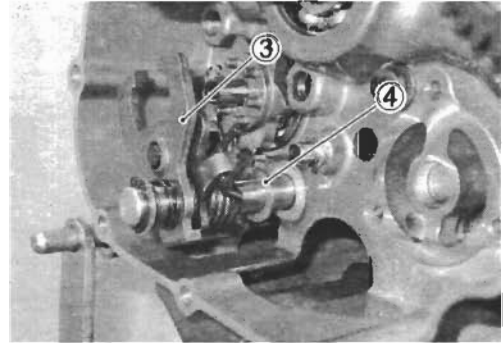

- Remove the gearshift cam plate bolt ⑤.
- Remove the gearshift cam plate ⑥.

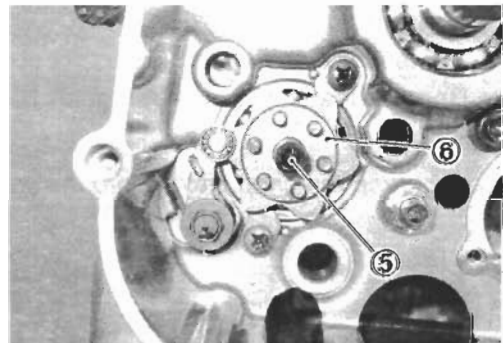

- Remove the gearshift cam stopper ⑦.

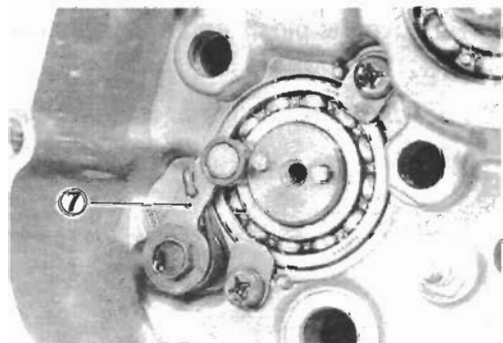

- Remove the following parts.
- ⑧ Gearshift cam stopper bolt
- ⑨ Gearshift cam stopper spring
- ⑩ Washer

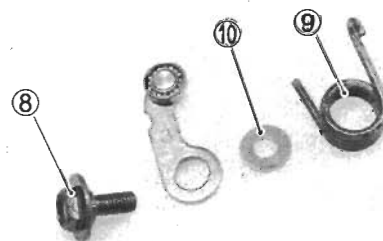

### OIL PIPE

- Remove the oil pipe stopper ①.

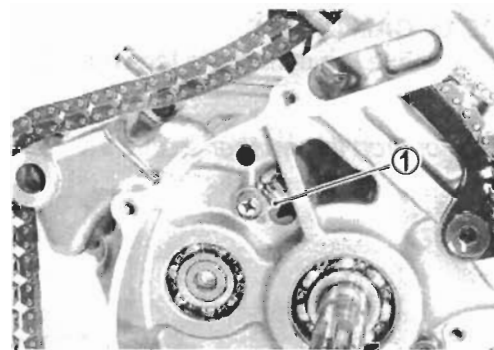

- Remove the oil pipe ②.



### PRIMARY DRIVE GEAR

- Hold the generator rotor with the special tool.

**TOOL** 09930-44530: Rotor holder

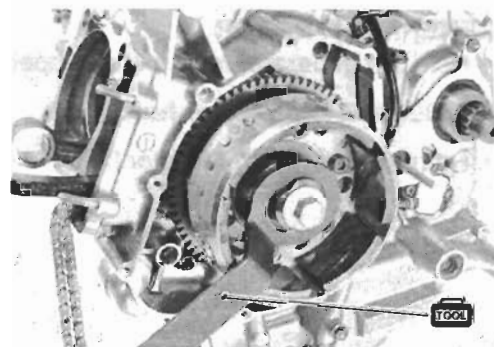

- Remove the primary drive gear bolt.

### CAUTION

This bolt has left-hand thread. Turning it counter-clockwise may cause damage.



- Remove the water pump drive gear ① and primary drive gear ②.

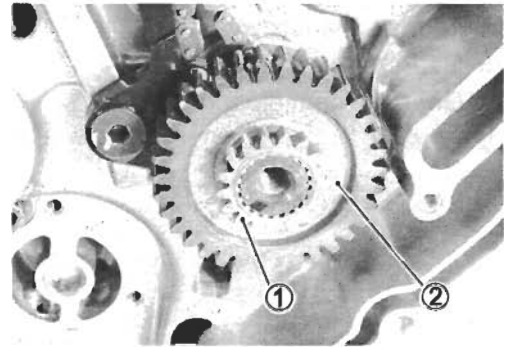

**REAR CAM CHAIN**

- Remove the cam chain tensioner ①.

**NOTE:**

*Do not drop the washer ② into the crankcase.*

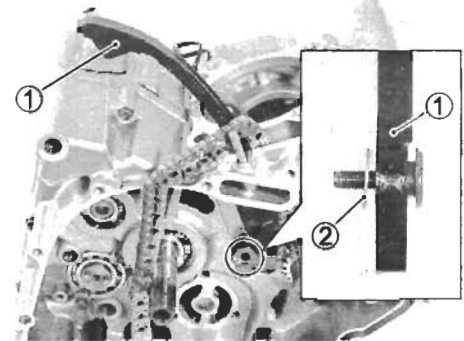

- Remove the rear cam chain ③ and cam chain drive sprocket ④.

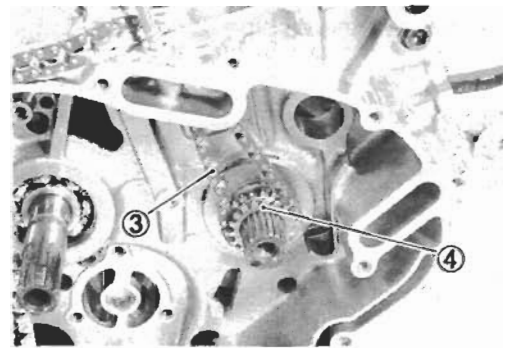

**GENERATOR ROTOR**

- Hold the generator rotor with the special tool.

**TOOL 09930-44530: Rotor holder**

- Remove the generator rotor bolt.

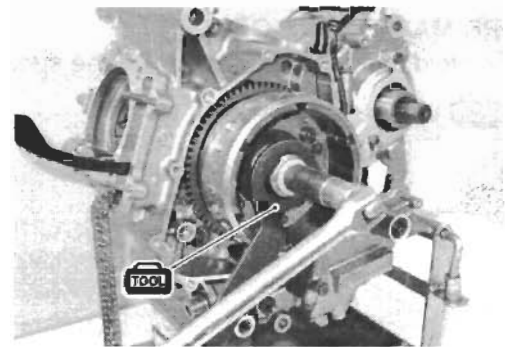

- Remove the generator rotor ① with the special tools.

**TOOL 09930-30450: Rotor remover**  
**09930-44530: Rotor holder**

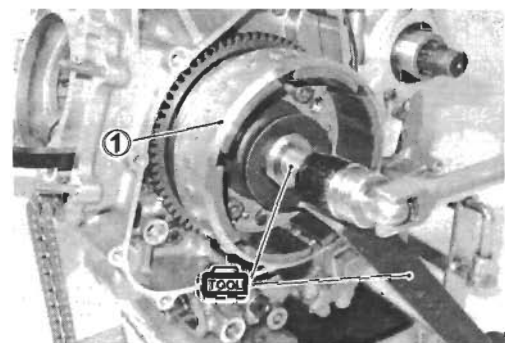

- Remove the key ②.
- Remove the starter driven gear ③.

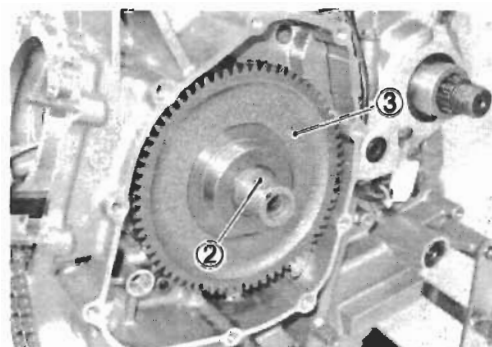

### FRONT CAM CHAIN

- Remove the cam chain tensioner ①.

#### NOTE:

Do not drop the washer ② into the crankcase.

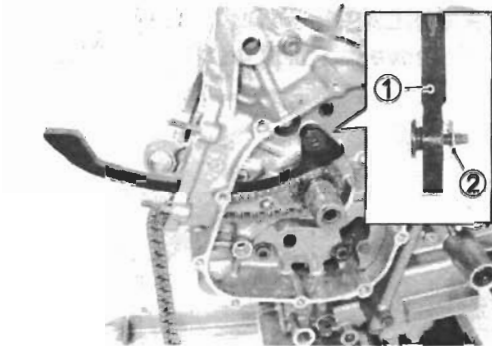

- Remove the front cam chain ③.

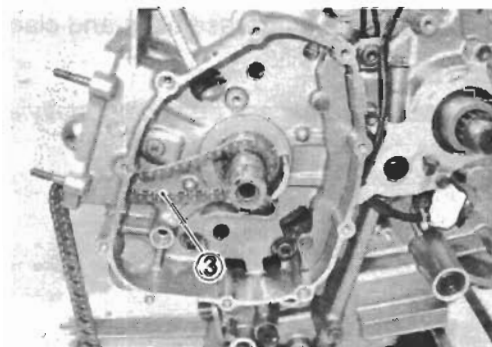

### GEAR POSITION SWITCH

- Remove the driveshaft oil seal retainer ①.

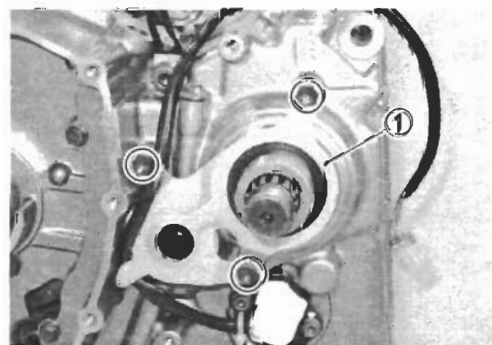

- Remove the gear position switch ②.

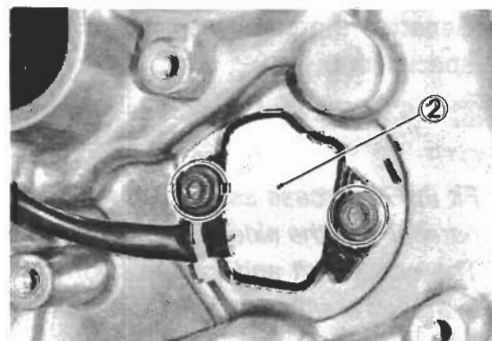

- Remove the O-ring ③.
- Remove the switch contacts ④ and springs ⑤.

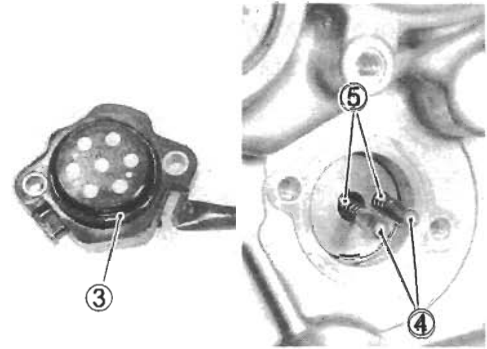

### CRANKCASE

- Remove the oil plate ①.

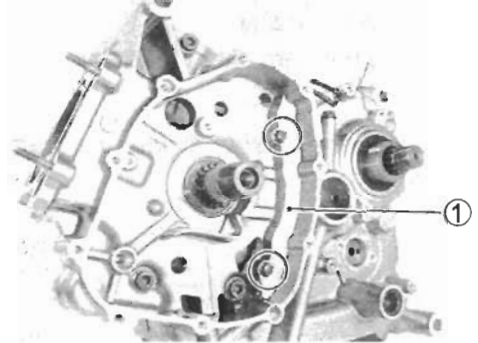

- Remove the crankcase bolts and clamp ②.

#### NOTE:

*Loosen the crankcase bolts diagonally and smaller sizes first.*

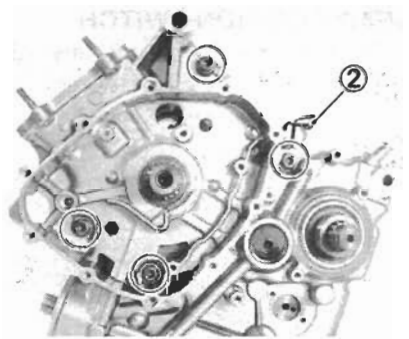
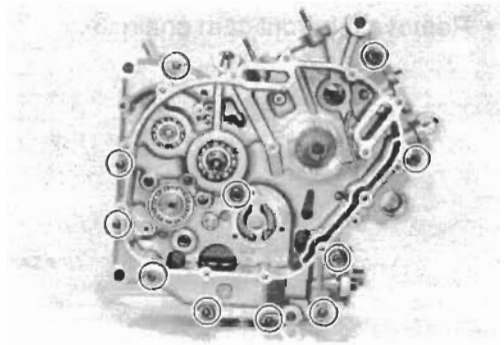

- Separate the crankcase into 2 parts, right and left with the special tool.

**TOOL** 09920-13120: Crankcase separating tool

#### NOTE:

- \* *Fit the crankcase separating tool, so that the tool arms are in parallel with the side of crankcase.*
- \* *The crankshaft and transmission components should remain in the left crankcase half.*

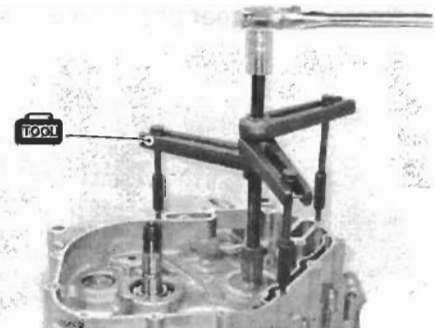

- Remove the O-rings ③ and dowel pins ④.

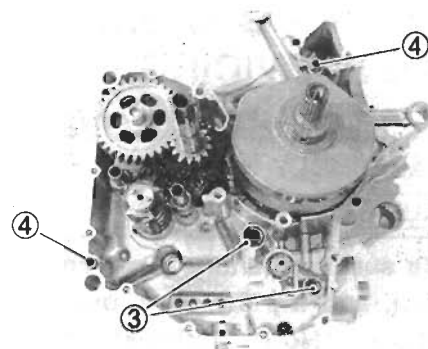

### CRANKSHAFT

- Remove the crankshaft ①.

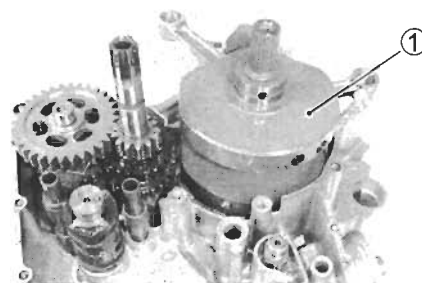

### TRANSMISSION

- Remove the gearshift fork shafts ①.
- Remove the gearshift cam ②.
- Remove the gear shift forks ③.

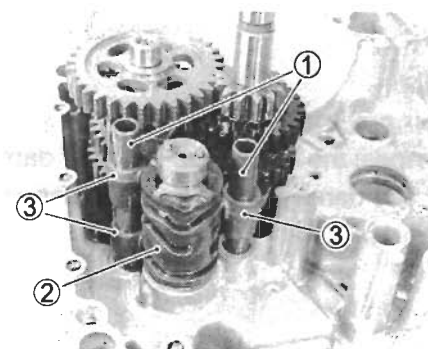

- Remove the driveshaft assembly ④ and countershaft assembly ⑤.

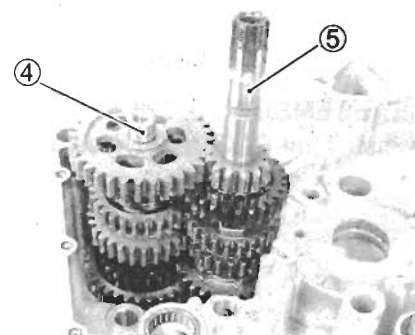

- Remove the engine sprocket spacer ⑥ and O-ring ⑦.

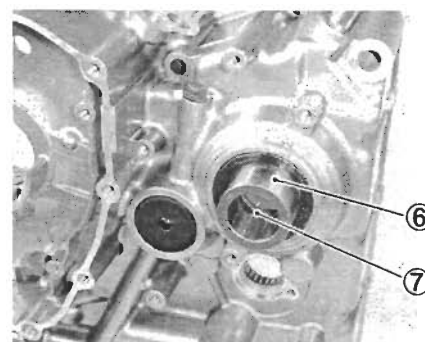

## ENGINE COMPONENTS INSPECTION AND SERVICING

### CYLINDER HEAD COVER

#### DISASSEMBLY

**CAUTION**

Be sure to identify each removed part as to its location, and lay the parts out in groups designated as "No.1", "No.2" "Exhaust", "Intake", so that each will be restored to the original location during assembly.

- Remove the PAIR reed valve cover ①.

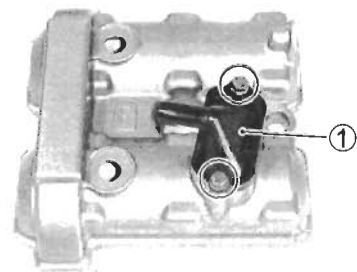

#### INSPECTION

Inspect the PAIR reed valve for damage and the carbon deposit. If any damage or the carbon deposit is found in the reed valve, replace it with a new one.



#### REASSEMBLY

- Install the PAIR reed valve as shown.

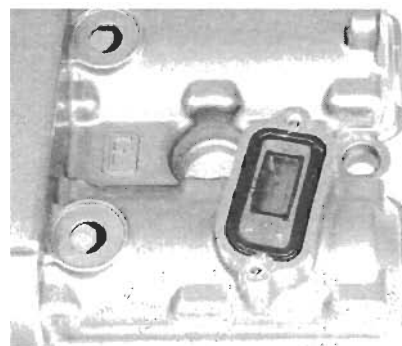

- Apply **THREAD LOCK** to the bolts and then install the **PAIR** reed valve cover.

**1342** 99000-32050: **THREAD LOCK "1342"**

**NOTE:**

The inlet pipe of the **PAIR** reed valve cover must face left side of the engine.

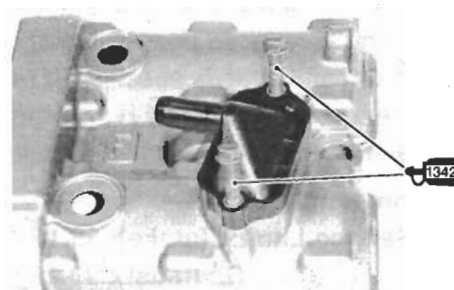

## CAMSHAFT/CAMSHAFT JOURNAL

### CAUTION

Be sure to identify each removed part as to its location, and lay the parts out in groups designated as "No.1", "No.2", "Exhaust", "Intake", so that each will be restored to the original location during assembly.

### CAMSHAFT

- All camshafts should be checked for runout and also for wear of cams and journals if the engine has been noted as giving abnormal noise, vibration or lack power output. Any of these conditions may be caused by camshafts worn down or distorted to the service limit.
- The camshafts can be identified by the embossed letters ① and cords ② stamped on the camshaft ends.

	Letter ①	Cord ②
No.1 (Front) intake camshaft	INF	K
No.1 (Front) exhaust camshaft	EXF	B
No.2 (Rear) intake camshaft	INR	M
No.2 (Rear) exhaust camshaft	EXR	D

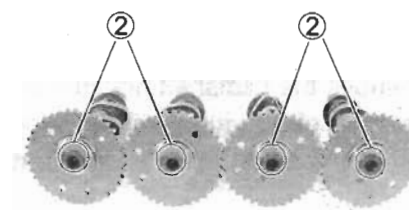
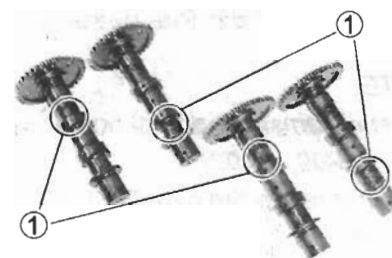



**CAM WEAR**

Worn-down cams are often the cause of mistimed valve operation resulting in reduced power output.

The limit of cam wear is specified for both intake and exhaust cams in terms of cam height  $\text{H}$ , which is to be measured with a micrometer. Replace camshaft if it wears worn down to the limit.

**DATA** Cam height  $\text{H}$ 

**Service Limit: (Intake): 35.18 mm (1.385 in)**

**(Exhaust): 33.18 mm (1.306 in)**

**TOOL** 09900-20202: Micrometer (25 – 50 mm)

**CAMSHAFT JOURNAL WEAR**

Determine whether or not each journal is worn down to the limit by measuring the oil clearance with the camshaft installed in place.

- Use the plastigauge to read the clearance at the widest portion, which is specified as follows:

**DATA** Camshaft journal oil clearance

**Service Limit (IN & EX): 0.150 mm (0.0059 in)**

**TOOL** 09900-22301: Plastigauge

**09900-22302: Plastigauge**

**NOTE:**

- \* Install camshaft journal holder to their original positions. (3-99, 3-102)
- \* Do not rotate the camshaft with the plastigauge in place.
- Tighten the camshaft journal holder bolts evenly and diagonally to the specified torque.

**TOOL** Camshaft journal holder bolt: 10 N·m  
(1.0 kgf-m, 7.0 lb-ft)

- Remove the camshaft holders, and read the width of the compressed plastigauge with envelope scale. This measurement should be taken at the widest part.

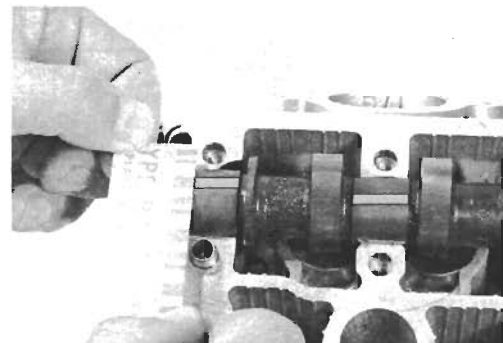
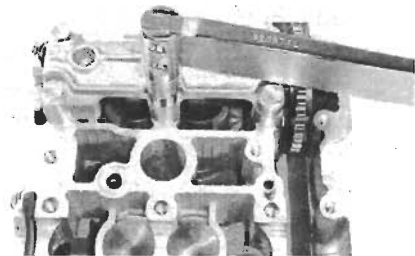
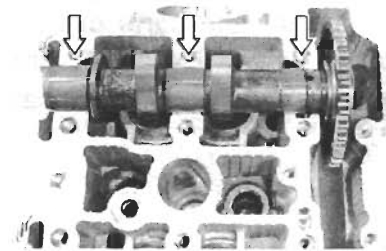
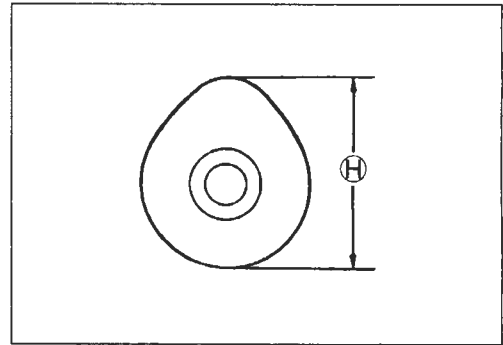

If the camshaft journal oil clearance measured exceeds the limit, measure the inside diameter of the camshaft journal holder and outside diameter of the camshaft journal. Replace the camshaft or the cylinder head depending upon which one exceeds the specification.

**DATA** Journal holder I.D.

Standard (IN & EX): 22.012 – 22.025 mm  
(0.8666 – 0.8671 in)

**TOOL** 09900-20602: Dial gauge (1/1000, 1 mm)  
09900-22403: Small bore gauge (18 – 35 mm)

**DATA** Camshaft journal O.D.

Standard (IN & EX): 21.959 – 21.980 mm  
(0.8645 – 0.8654 in)

**TOOL** 09900-20205: Micrometer (0 – 25 mm)

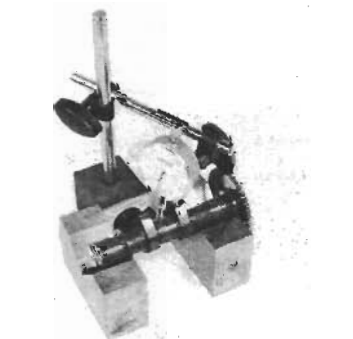

### CAMSHAFT RUNOUT

Measure the runout using the dial gauge. Replace the camshaft if the runout exceeds the limit.

**DATA** Camshaft runout

Service Limit (IN & EX): 0.1 mm (0.004 in)

**TOOL** 09900-20607: Dial gauge (1/100 mm)  
09900-20701: Magnetic stand  
09900-21304: V-block set (100 mm)

### CAM CHAIN TENSION ADJUSTER

Check that the push rod ① can slide smoothly with the lock ② of the ratchet mechanism released. If it does not slide smoothly or the ratchet mechanism is worn or damaged, replace the cam chain tension adjuster with a new one.

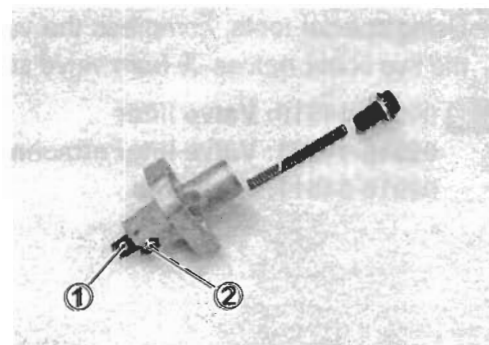

### CAM CHAIN TENSIONER

Check the contacting surface of the cam chain tensioner. If it is worn or damaged, replace it with a new one.

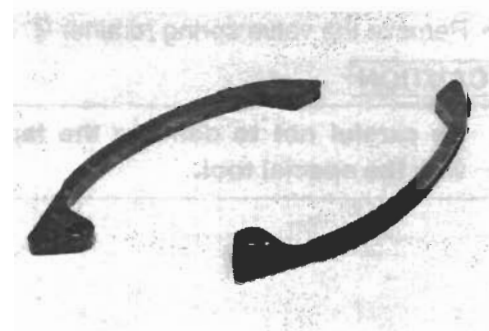

**CAM CHAIN GUIDE**

Check the contacting surface of the cam chain guide.  
If it is worn or damaged, replace it with a new one.

**CYLINDER HEAD****VALVE AND VALVE SPRING DISASSEMBLY**

- Remove the tappets ① and shims ② by fingers or magnetic hand.

**CAUTION**

Identify the position of each removed part.

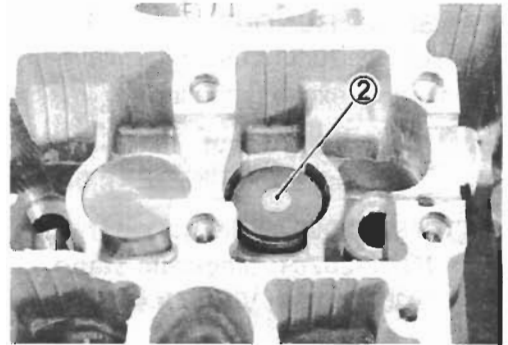
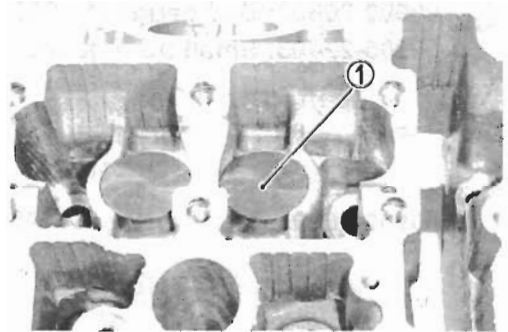

- Using special tools, compress the valve springs and remove the two cotter halves ③ from valve stem.

- TOOL** 09916-14510: Valve lifter  
09916-14521: Valve lifter attachment  
09916-84511: Tweezers

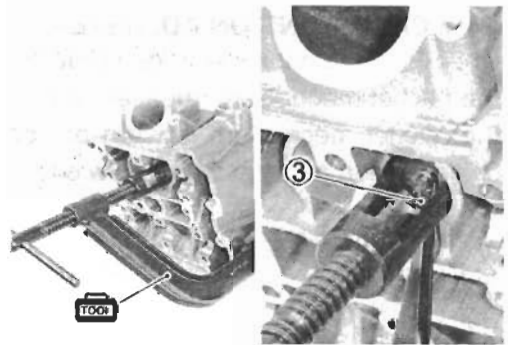

- Remove the valve spring retainer ④ and valve springs ⑤.

**CAUTION**

Be careful not to damage the tappet sliding surface with the special tool.

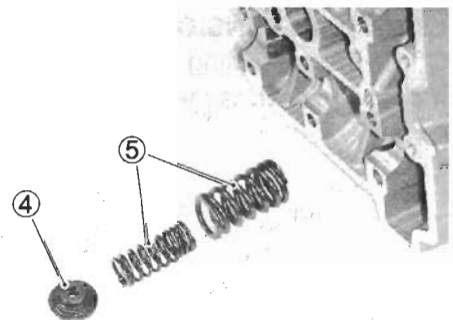

- Pull out the valve from the other side.

- Remove the oil seals ⑥ and spring seats ⑦.

**CAUTION**

Do not reuse the removed oil seals.

**CYLINDER HEAD DISTORTION**

Decarbonize the combustion chambers.

Check the gasketed surface of the cylinder head for distortion with a straightedge and thickness gauge, taking a clearance reading at several places indicated.

If the largest reading at any position of the straightedge exceeds the limit, replace the cylinder head.

**DATA** Cylinder head distortion

Standard: 0.05 mm (0.002 in)

**TOOL** 09900-20803: Thickness gauge

**VALVE STEM RUNOUT**

Support the valve using V-blocks and check its runout using the dial gauge as shown.

If the runout exceeds the service limit, replace the valve.

**DATA** Valve stem runout

Service Limit: 0.05 mm (0.002 in)

**TOOL** 09900-20607: Dial gauge (1/100 mm)

09900-20701: Magnetic stand

09900-21304: V-block set (100 mm)

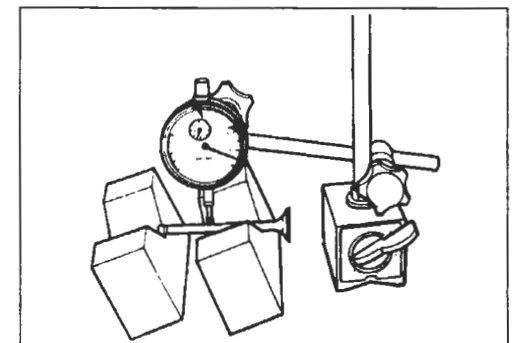
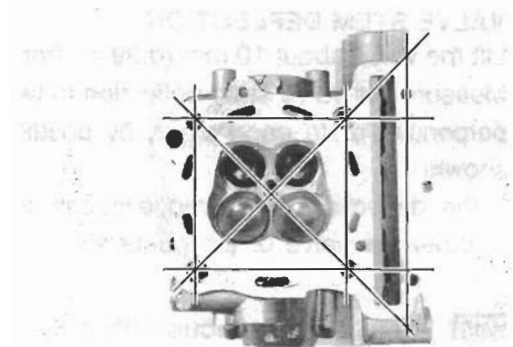
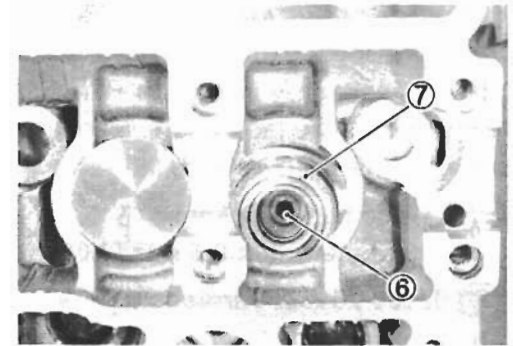
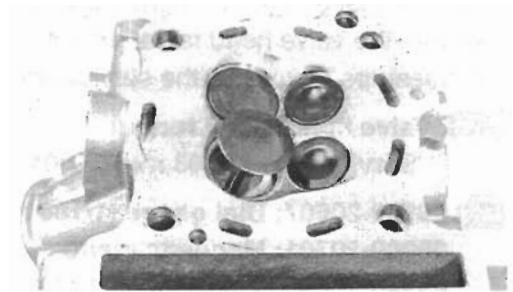

**VALVE HEAD RADIAL RUNOUT**

Place the dial gauge at a right angle to the valve head face and measure the valve head radial runout.

If it measures more than the service limit, replace the valve.

**DATA** Valve head radial runout

Service Limit: 0.03 mm (0.001 in)

**TOOL** 09900-20607: Dial gauge (1/100 mm)

09900-20701: Magnetic stand

09900-21304: V-block set (100 mm)

**VALVE FACE WEAR**

Visually inspect each valve face for wear. Replace any valve with an abnormally worn face. The thickness of the valve face decreases as the face wears. Measure the valve face  $\text{\textcircled{T}}$ . If it is out of specification, replace the valve with a new one.

**DATA** Valve head thickness  $\text{\textcircled{T}}$ 

Service Limit: 0.5 mm (0.02 in)

**TOOL** 09900-20102: Vernier calipers

**VALVE STEM DEFLECTION**

Lift the valve about 10 mm (0.39 in) from the valve seat.

Measure the valve stem deflection in two directions, "X" and "Y" perpendicular to each other, by positioning the dial gauge as shown.

If the deflection measured exceeds the limit, then determine whether the valve or the guide should be replaced with a new one.

**DATA** Valve stem deflection (IN & EX)

Service Limit: 0.35 mm (0.014 in)

**TOOL** 09900-20607: Dial gauge (1/100 mm)

09900-20701: Magnetic stand

**VALVE STEM WEAR**

If the valve stem is worn down to the limit, as measured with a micrometer, where the clearance is found to be in excess of the limit indicated, replace the valve.

If the stem is within the limit, then replace the guide.

- After replacing valve or guide, be sure to recheck the clearance.

**DATA** Valve stem O.D.

Standard (IN): 4.465 – 4.480 mm (0.1758 – 0.1764 in)

(EX): 4.455 – 4.470 mm (0.1754 – 0.1760 in)

**TOOL** 09900-20205: Micrometer (0 – 25 mm)

**NOTE:**

If valve guides have to be removed for replacement after inspecting related parts, carry out the steps shown in valve guide servicing.

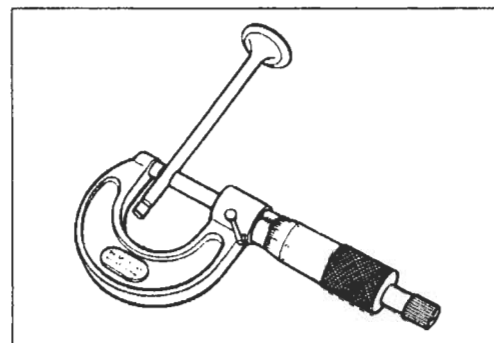
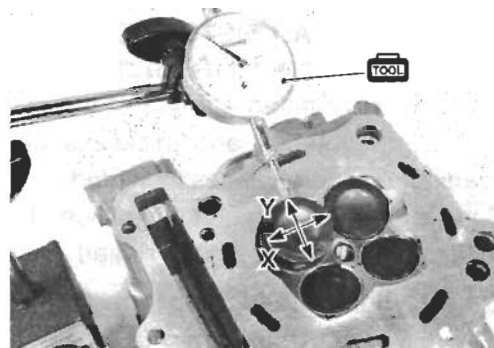
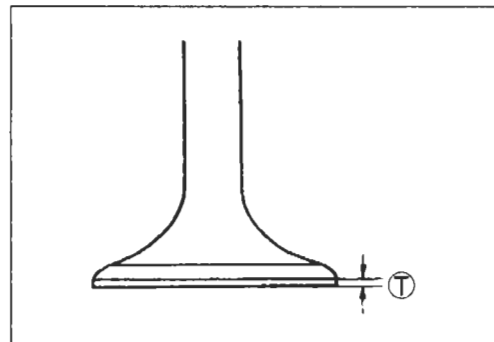
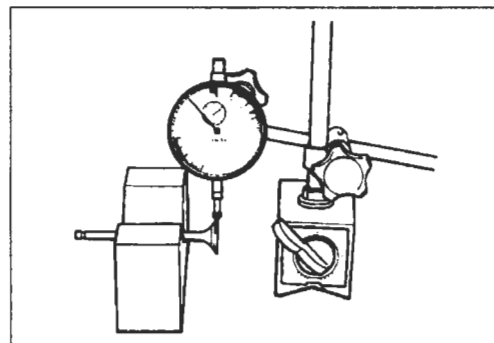

**VALVE GUIDE SERVICING**

- Using the valve guide remover, drive the valve guide out toward the intake or exhaust camshaft side.

**TOOL** 09916-43210: Valve guide remover/installer

**NOTE:**

- \* Discard the removed valve guide subassemblies.
- \* Only oversized valve guides are available as replacement parts. (Part No. 11115-18D72)

- Re-finish the valve guide holes in cylinder head with the reamer and handle.

**TOOL** 09916-34580: Valve guide reamer  
09916-34542: Reamer handle

**CAUTION**

**When refinishing or removing the reamer from the valve guide hole, always turn it clockwise.**

- Apply engine oil to the valve guide hole, and valve guide.
- Drive the valve guide into the hole with the special tools.

**TOOL** 09916-43210: Valve guide installer/remover  
09916-53330: Attachment

**NOTE:**

Install the valve guide until the attachment ① contacts with the cylinder head ②.

**CAUTION**

**Failure to oil the valve guide hole before driving the new guide into place may result in a damaged guide or head.**

- After installing the valve guides, re-finish their guiding bores using the reamer.
- Clean and oil the guides after reaming.

**TOOL** 09916-33210: Valve guide reamer  
09916-34542: Valve guide reamer handle

**NOTE:**

Insert the reamer from the combustion chamber and always turn the reamer handle clockwise.

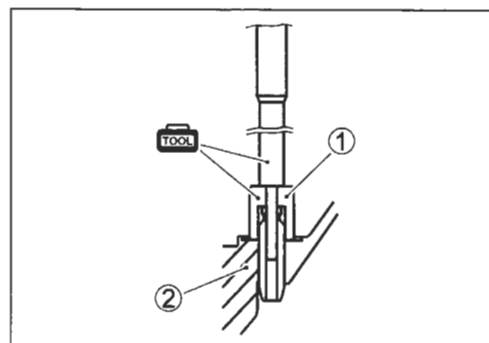
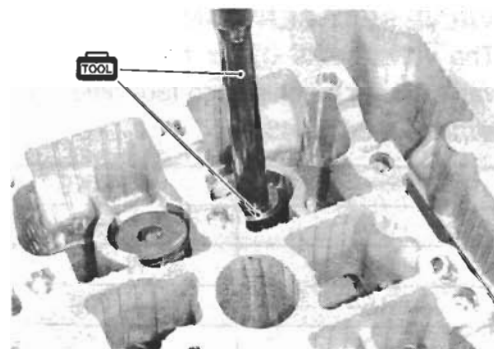
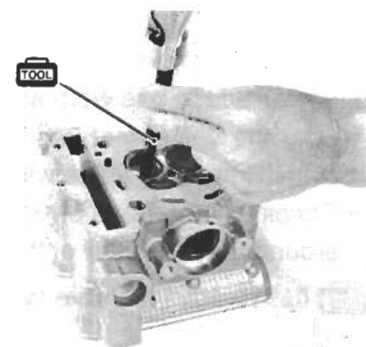

**VALVE SEAT WIDTH INSPECTION**

Visually check for valve seat width on each valve face.

If the valve face has worn abnormally, replace the valve.

- Coat the valve seat with Prussian Blue and set the valve in place. Rotate the valve with light pressure.
- Check that the transferred blue on the valve face is uniform all around and in center of the valve face.

**TOOL** 09916-10911: Valve lapper set

If the seat width  $\text{W}$  measured exceeds the standard value, or seat width is not uniform reface the seat using the seat cutter.

**DATA** Valve seat width  $\text{W}$

Standard: 0.9 – 1.1 mm (0.035 – 0.043 in)

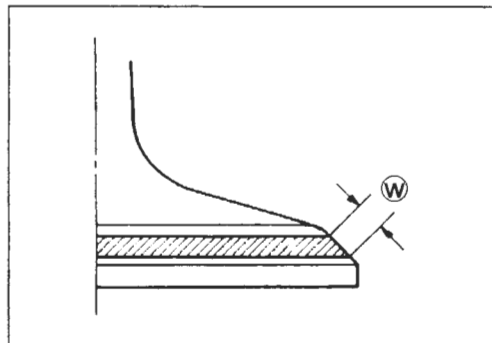
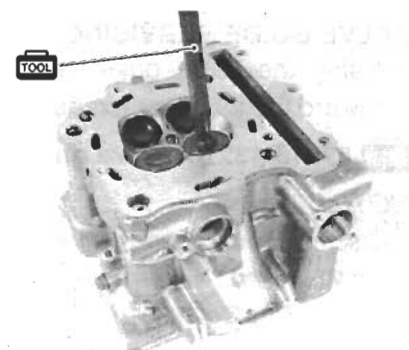

**VALVE SEAT SERVICING**

The valve seats ① for both the intake valve ② and exhaust valve ③ are machined to four different angles. The seat contact surface is cut at 45°.

	INTAKE	EXHAUST
15°		N-121
30°	N-128	
45°	N-128	N-122
60°	N-111	N-111

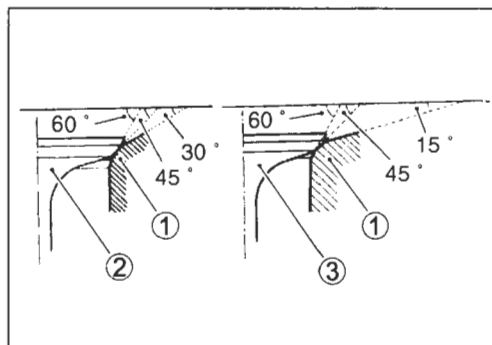

- TOOL** 09916-21111: Valve seat cutter set
- 09916-22430: Valve seat cutter (N-128)
- 09916-20640: Solid pilot (N-100-4.5)

**NOTE:**

- \* The valve seat cutters (N-121), (N-122) and (N-111) are included in the valve seat cutter set (09916-21111).
- \* Use the solid pilot (N-100-4.5) along with the valve seat cutter.

**CAUTION**

The valve seal contact area must be inspected after each cut.

- When installing the solid pilot ①, rotate it slightly. Seat the pilot snugly. Install the 45° cutter, attachment and T-handle.

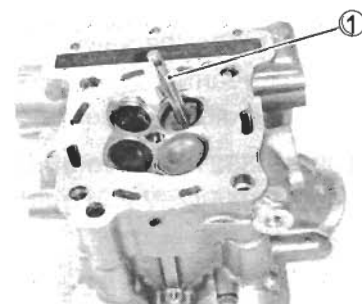

**INITIAL SEAT CUT**

- Using the 45 ° cutter, descale and clean up the seat. Rotate the cutter one or two turns.
- Measure the valve seat width  $\text{\textcircled{W}}$  after every cut.

**NOTE:**

*Cut only the minimum amount necessary from the seat to prevent the possibility of the valve stem becoming too close to the camshaft.*

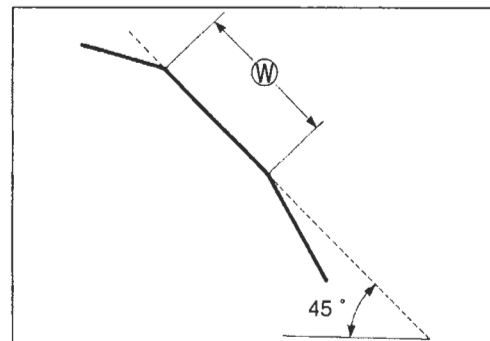

- If the valve seat is pitted or burned, use the 45 ° cutter to condition the seat some more.

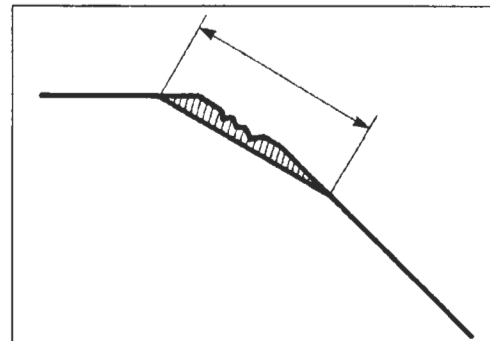
**TOP NARROWING CUT**

- If the contact area  $\text{\textcircled{W}}$  is too high on the valve, or if it is too wide, use the 15 ° (for the exhaust side  $\text{\textcircled{A}}$ ) and the 30 ° (for the intake side  $\text{\textcircled{B}}$ ) to lower and narrow the contact area.

**NOTE:**

*Contact area too high and too wide on face of valve.*

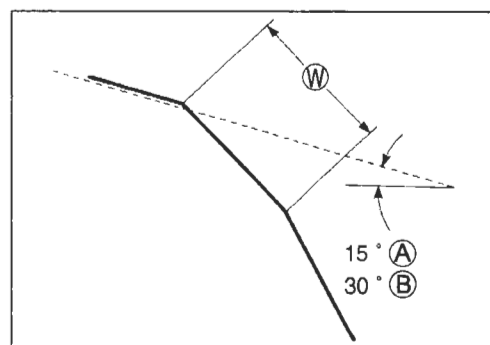
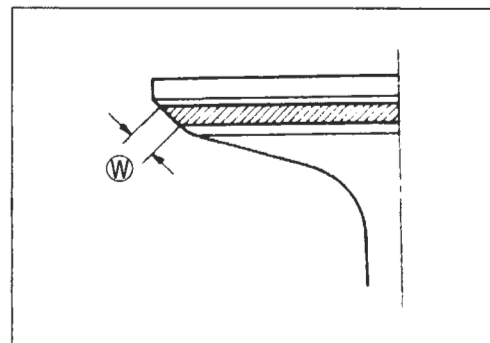
**BOTTOM NARROWING CUT**

- If the contact area  $\text{\textcircled{W}}$  is too wide or too low, use the 60 ° cutter to narrow and raise the contact area.

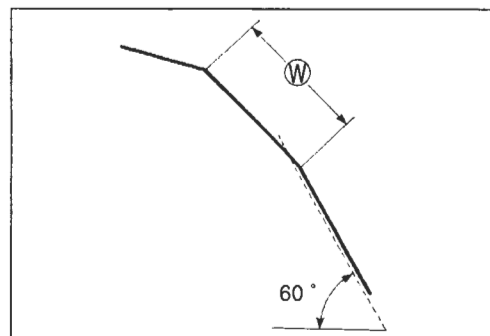



**FINAL SEAT CUT**

- If the contact area  $\textcircled{W}$  is too low or too narrow, use the 45 ° cutter to raise and widen the contact area.

**NOTE:**

- \* After cutting the 15 °, 30 ° and 60 ° angles, it is possible that the valve seat (45 °) is too narrow. If so, re-cut the valve seat to the correct width.
- \* Contact area too low and too narrow on face of valve.

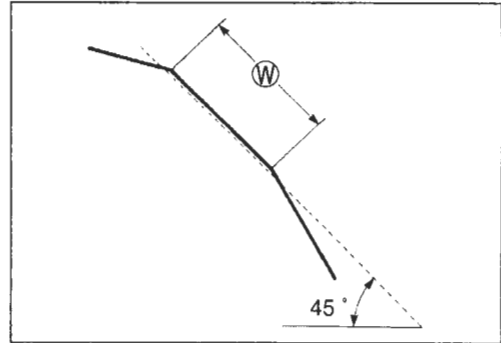
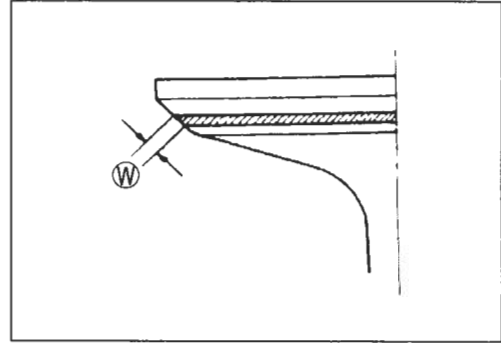

- After the desired seat position and width is achieved, use the 45 ° cutter very lightly to clean up any burrs caused by the previous cutting operations.

**CAUTION**

Do not use lapping compound after the final cut is made.

The finished valve seat should have a velvety smooth finish but not a highly polished or shiny finish. This will provide a soft surface for the final seating of the valve which will occur during the first few seconds of engine operation.

- Clean and assemble the head and valve components. Fill the intake and exhaust ports with gasoline to check for leaks.
- If any leaks occur, inspect the valve seat and face for burrs or other things that could prevent the valve from sealing.

**▲ WARNING**

Always use extreme caution when handling gasoline.

**NOTE:**

After servicing the valve seats, be sure to check the tappet clearance after the cylinder head has been reinstalled. (☞ 2-8)

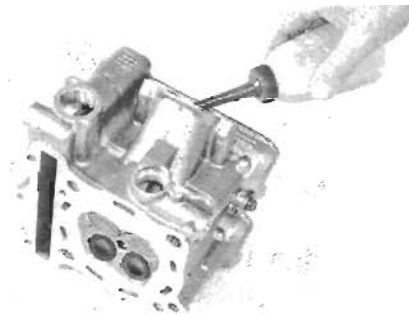
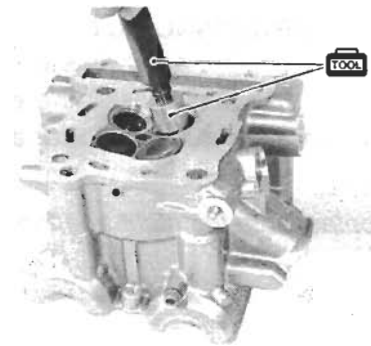

**VALVE STEM END CONDITION**

- Check the valve stem end face for pitting and wear.

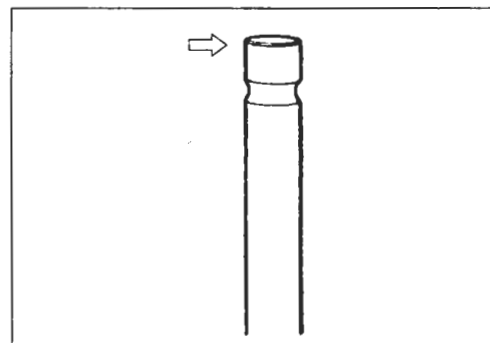
**VALVE SPRING**

The force of the coil springs keeps the valve seat tight. Weakened springs result in reduced engine power output, and often account for the chattering noise coming from the valve mechanism.

- Check the valve springs for proper strength by measuring their free length and also by the force required to compress them. If the spring length is less than the service limit, or if the force required to compress the spring does not fall within the range specified, replace both the inner and outer springs as a set.

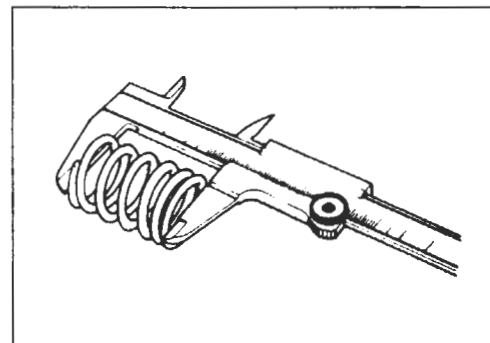
**DATA** Valve spring free length (IN & EX)

Service limit: INNER : 36.8 mm (1.45 in)  
 OUTER: 39.8 mm (1.57 in)

**DATA** Valve spring tension

Standard: (IN & EX) INNER : 4.2 – 4.8 kgf/29.9 mm  
 (9.26 – 10.58 lbs/1.18 in)  
 OUTER: 17.0 – 19.6 kgf/33.4 mm  
 (37.48 – 43.21 lbs/1.31 in)

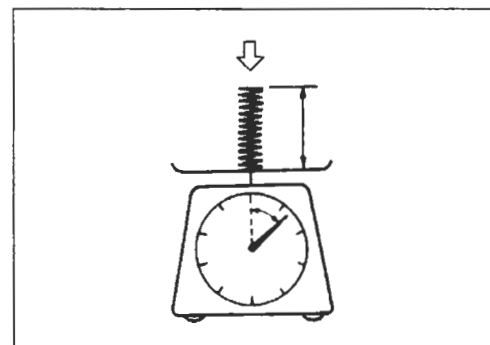

**TOOL** 09900-20102: Vernier calipers

**VALVE AND VALVE SPRING INSTALLATION**

- Install the valve spring seats ①.
- Apply engine oil to each oil seal ②.
- Install the oil seal.

**CAUTION**

**Do not reuse the removed oil seals.**

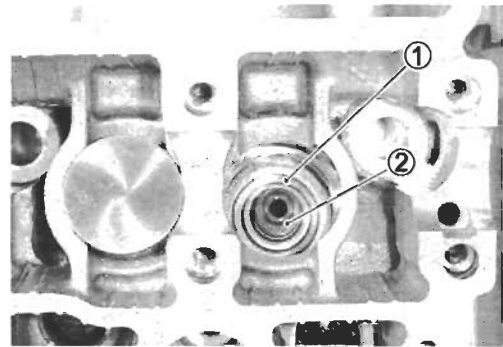

- Insert the valves, with their stems coated with MOLYBDENUM OIL SOLUTION all around and along the full stem length without any break.

**CAUTION**

**When inserting each valve, take care not to damage the lip of the oil seal.**

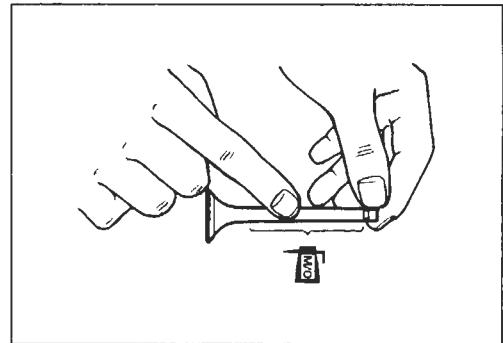

**MOLYBDENUM OIL SOLUTION**

- Install the valve springs with the small-pitch portion (A) facing cylinder head.
- ⓑ Large-pitch portion
  - ⓒ UPWARD
  - ⓓ Paint

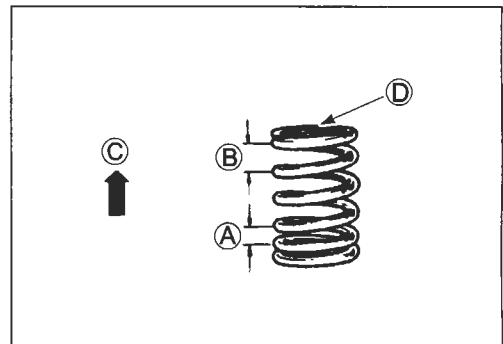

- Put on the valve spring retainer ①, and using the valve lifter, press down the springs, fit the cotter halves to the stem end, and release the lifter to allow the cotter ② to wedge in between retainer and stem. Be sure that the rounded lip (A) of the cotter fits snugly into the groove (B) in the stem end.

- TOOL** 09916-14510: Valve lifter
- 09916-14521: Valve lifter attachment
- 09916-84511: Tweezers

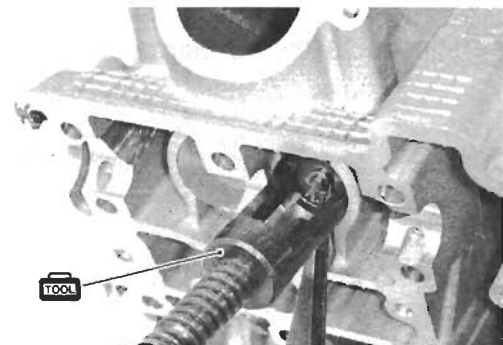

**CAUTION**

**Be sure to restore each spring and valve to their original positions.**

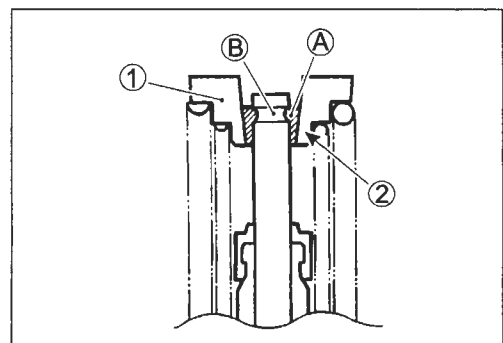

- Install the tappet shim and the tappet to their original position.

**NOTE:**

- \* Before installing them, apply engine oil to the shims and tappets all over, also to the tappet chambers on the cylinder head.
- \* When seating the tappet shim, be sure the figure printed surface faces the tappet.

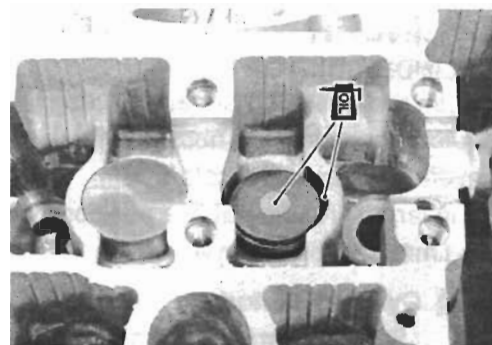
**OIL JET REMOVAL**

- Remove the oil jets ①.

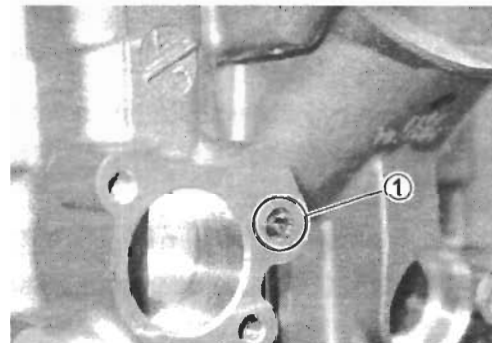
**OIL JET INSPECTION AND CLEANING**

- Check the oil jets for clogging.
- If they are clogged, clean their oil passage with a proper wire and compressed air.

- ① Oil jet (#8) (For cam chain tension adjuster)

**OIL JET INSTALLATION**

- Fit the new O-rings to each oil jets.

**CAUTION**

**Use the new O-rings to prevent oil leakage.**

**NOTE:**

- \* Apply grease to the O-rings when installing the oil jets.
- \* Apply engine oil to the oil jet hole on the cylinder head.

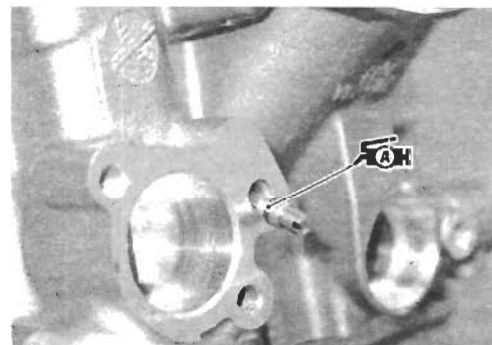

## CYLINDER

### CYLINDER DISTORTION

Check the gasketed surface of the cylinder for distortion with a straightedge and thickness gauge, taking a clearance reading at several places as indicated.

If the largest reading at any position of the straightedge exceeds the limit, replace the cylinder.

**DATA** Cylinder distortion  
Service Limit: 0.05 mm (0.002 in)

**TOOL** 09900-20803: Thickness gauge

### CYLINDER BORE

Inspect the cylinder wall for any scratches, nicks or other damage. Measure the cylinder bore diameter at six places.

**DATA** Cylinder bore  
Standard: 81.000 – 81.015 mm (3.1890 – 3.1896 in)

**TOOL** 09900-20508: Cylinder gauge set

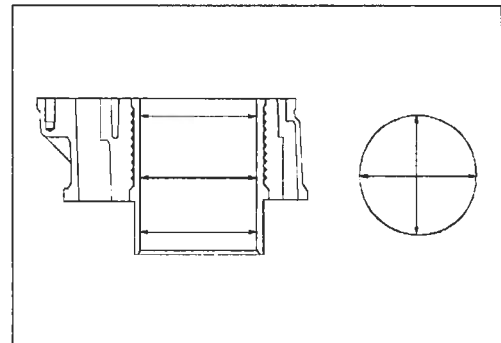
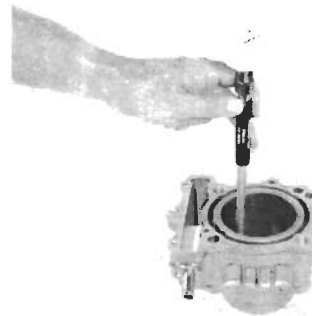
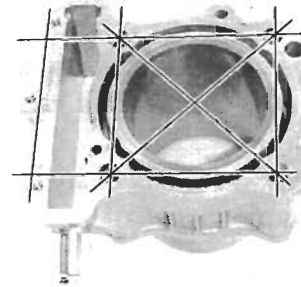

## PISTON AND PISTON RING

### PISTON DIAMETER

- Using a micrometer, measure the piston outside diameter at 20 mm (0.79 in)  $\text{\textcircled{A}}$  from the piston skirt end.

If the measurement is less than the limit, replace the piston.

#### **DATA** Piston diameter

**Service Limit: 80.88 mm (3.184 in)**  
at 20 mm (0.79 in) from the skirt end

**TOOL** 09900-20204: Micrometer (75 – 100 mm)

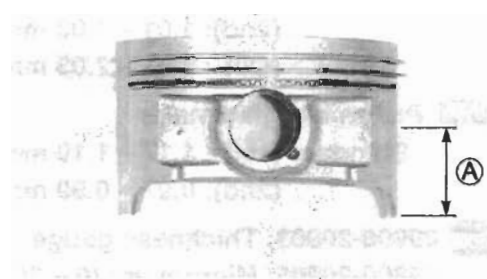

### PISTON-TO CYLINDER CLEARANCE

As a result of the previous measurement, if the piston-to-cylinder clearance exceeds the service limit, rebore the cylinder and use an oversize piston or replace both the cylinder and piston.

#### **DATA** Piston-to-cylinder clearance

**Standard: 0.055 – 0.065 mm (0.0022 – 0.0026 in)**

### PISTON-RING-TO-GROOVE CLEARANCE

Measure the side clearances of the 1st and 2nd piston rings using the thickness gauge.

If any of the clearances exceed the limit, replace both the piston and piston rings.

#### **DATA** Piston-ring-to-groove clearance

**Service Limit (1st) : 0.18 mm (0.0071 in)**  
**(2nd): 0.15 mm (0.0059 in)**

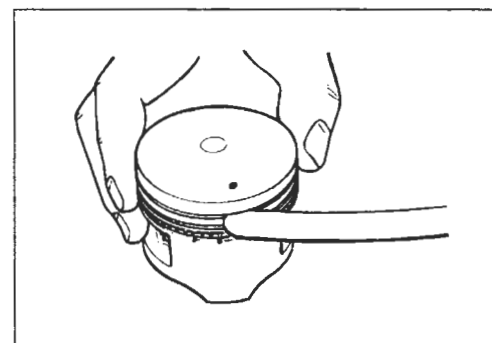

**DATA** Piston ring groove width  
 Standard (1st) : 1.21 – 1.23 mm (0.0476 – 0.0484 in)  
 (2nd): 1.01 – 1.03 mm (0.0398 – 0.0406 in)  
 (Oil) : 2.01 – 2.03 mm (0.0791 – 0.0799 in)

**DATA** Piston ring thickness  
 Standard (1st) : 1.17 – 1.19 mm (0.0461 – 0.0469 in)  
 (2nd): 0.97 – 0.99 mm (0.0382 – 0.0390 in)

**TOOL** 09900-20803: Thickness gauge  
 09900-20205: Micrometer (0 – 25 mm)

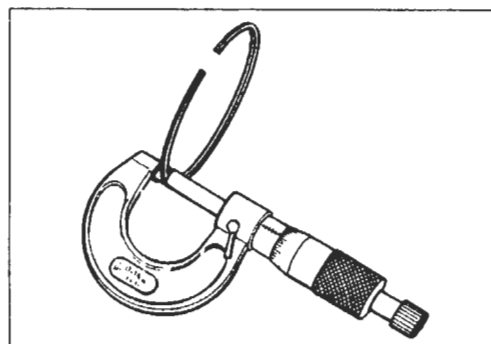

**PISTON RING FREE END GAP AND PISTON RING END GAP**

- Measure the piston ring free end gap using vernier calipers.
- Next, fit the piston ring squarely into the cylinder and measure the piston ring end gap using the thickness gauge.

If any of the measurements exceed the service limit, replace the piston ring with a new one.

**DATA** Piston ring free end gap  
 Service Limit (1st) : 7.6 mm (0.30 in)  
 (2nd): 8.8 mm (0.35 in)

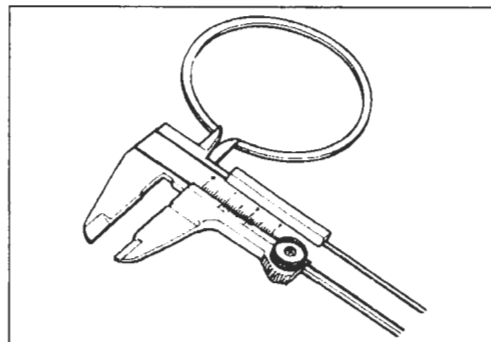

**TOOL** 09900-20102: Vernier calipers

**DATA** Piston ring end gap  
 Service Limit (1st) : 0.70 mm (0.028 in)  
 (2nd): 0.70 mm (0.028 in)

**TOOL** 09900-20803: Thickness gauge



**OVERSIZE PISTON RING**

The following two types of oversize piston rings are used. They bear the following identification numbers.

SIZE	1st	2nd
STD	NIL	NIL
0.5 mm O.S.	50	50

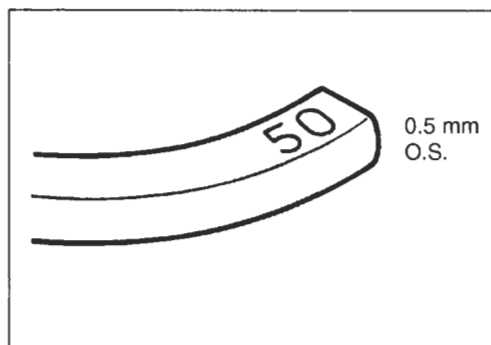

## OVERSIZE OIL RING

The following two types of oversize oil rings are available as optional parts.

They bear the following identification marks.

SIZE	COLOR	
	SIDE RAIL	SPACER
STD	NIL	RED
0.5 mm O.S.	BLUE	BLUE

- Measure the outside diameter to identify the size.

① Oil ring spacer

Ⓐ Paint

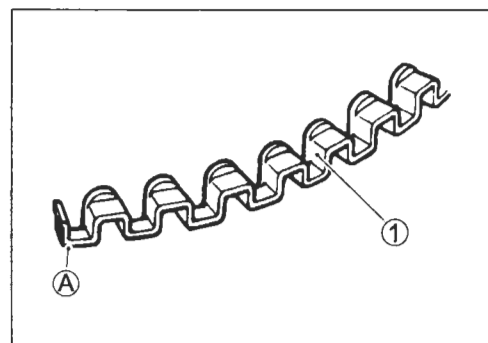

## PISTON PINS AND PIN BORE

Measure the piston pin bore inside diameter using the small bore gauge.

If the measurement is out of specifications replace the piston.

**DATA** Piston pin bore I.D.

Service Limit: 20.030 mm (0.7886 in)

**TOOL** 09900-20602: Dial gauge (1/1000 mm)

09900-22403: Small bore gauge (18 – 35 mm)

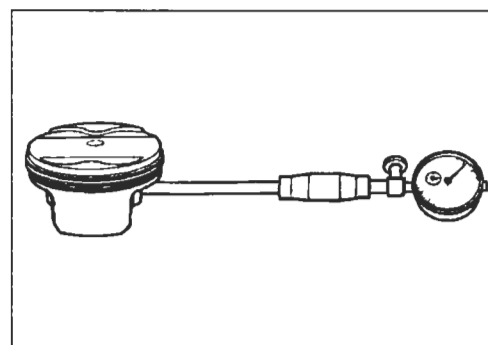

Measure the piston pin outside diameter at three positions using the micrometer.

If any of the measurements are out of specification, replace the piston pin.

**DATA** Piston pin O.D.

Service Limit: 19.98 mm (0.7866 in)

**TOOL** 09900-20205: Micrometer (0 – 25 mm)

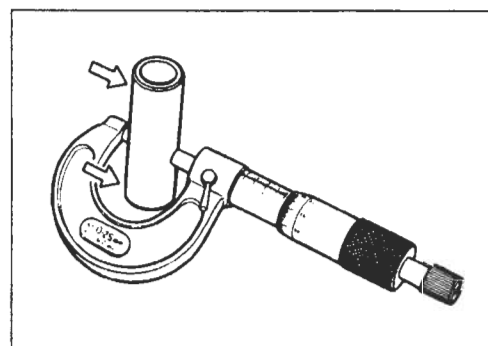

## CONROD AND CRANKSHAFT

### CONROD SMALL END I.D.

Using a small bore gauge, measure the inside diameter of the conrod small end.

**DATA** Conrod small end I.D.

Service Limit: 20.040 mm (0.7890 in)

**TOOL** 09900-20602: Dial gauge (1/1 000 mm, 1 mm)

09900-22403: Small bore gauge (18 – 35 mm)

If the inside diameter of the conrod small end exceeds the limit, replace the conrod.

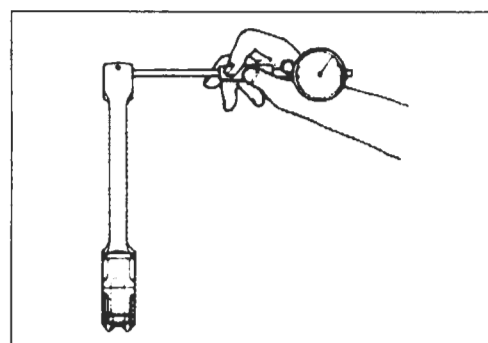



**CONROD BIG END SIDE CLEARANCE**

Check the conrod side clearance by using a thickness gauge.  
If the clearance exceeds the limit, replace conrod or crankshaft.

**DATA** Conrod big end side clearance  
Service Limit: 0.50 mm (0.020 in)

**TOOL** 09900-20803: Thickness gauge

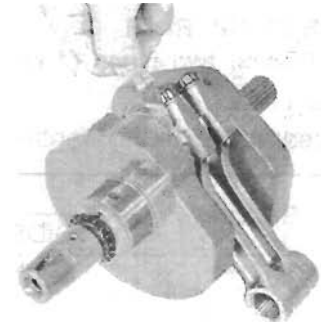
**CONROD BIG END WIDTH**

Check the conrod big end width.

**DATA** Conrod big end width  
Standard: 20.95 – 21.00 mm (0.825 – 0.827 in)

**TOOL** 09900-20205: Micrometer (0 – 25 mm)

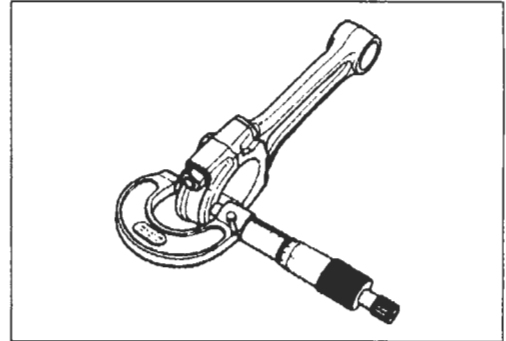
**CRANK PIN WIDTH**

Check the crank pin width (A).

**DATA** Crank pin width  
Standard: 42.17 – 42.22 mm (1.660 – 1.662 in)

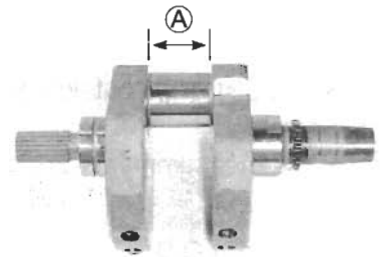
**CONROD REMOVAL AND BEARING INSPECTION**

- Loosen the bearing cap bolts, and tap the bearing cap bolt lightly with plastic hammer to remove the bearing cap.

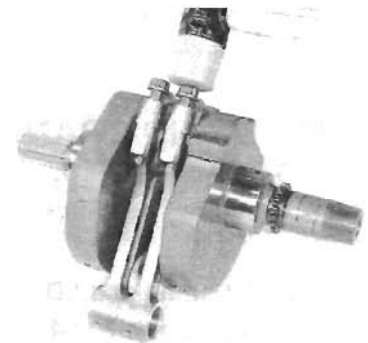

- Remove the conrods, and mark them to identify the cylinder position.

Inspect the bearing surfaces for any sign of fusion, pitting, burn, or flaws. If any, replace them with a specified set of bearings.

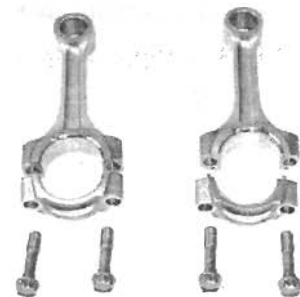

**CONROD-CRANK PIN BEARING SELECTION**

- Place the plastigauge axially along the crank pin, avoiding the oil hole, at TDC or BDC side as shown.

**TOOL** 09900-22301: Plastigauge  
09900-22302: Plastigauge

- Tighten the conrod cap bolts to the specified torque, in two stages. (3-57)

**CAUTION**

**Never rotate the crankshaft or conrod when a piece of plastigauge is installed.**

- Remove the bearing caps and measure the width of the compressed plastigauge using the envelope scale. This measurement should be taken at the widest part of the compressed plastigauge.

**DATA** Conrod big end oil clearance

Standard: 0.032 – 0.056 mm (0.0013 – 0.0022 in)

Service Limit: 0.080 mm (0.0031 in)

- If the oil clearance exceeds the service limit, select the specified bearings from the bearing selection table.
- Check the corresponding conrod I.D. code numbers ("1" or "2") **A**.

- Check the corresponding crank pin O.D. code numbers ("1", "2" or "3") **B**.

Bearing selection table

	Code	Crank pin O.D. <b>B</b>		
		1	2	3
Conrod I.D. <b>A</b>	1	Green	Black	Brown
	2	Black	Brown	Yellow

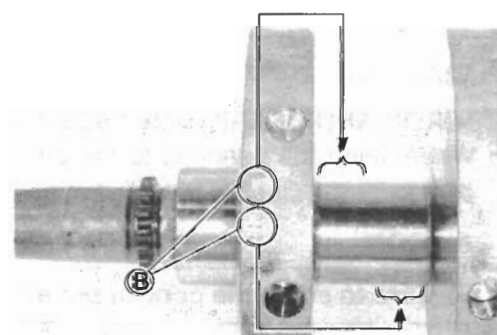
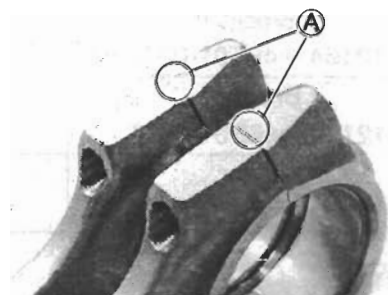
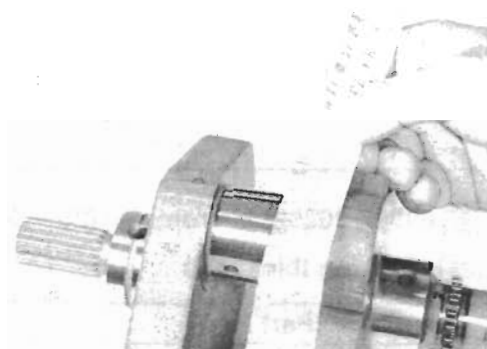
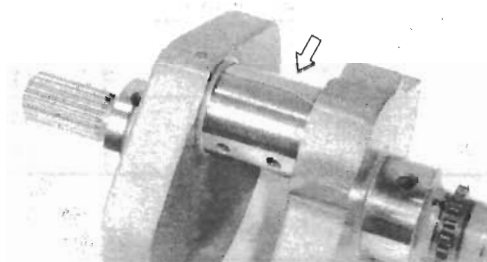

**DATA** Conrod I.D.

Code	I.D. specification
1	41.000 – 41.008 mm (1.6142 – 1.6145 in)
2	41.008 – 41.016 mm (1.6145 – 1.6148 in)

**DATA** Crank pin O.D.

Code	O.D. specification
1	37.992 – 38.000 mm (1.4957 – 1.4961 in)
2	37.984 – 37.992 mm (1.4954 – 1.4957 in)
3	37.976 – 37.984 mm (1.4951 – 1.4954 in)

**TOOL** 09900-20202: Micrometer (25 – 50 mm)**DATA** Bearing thickness

Color (Part No.)	Thickness
Green (12164 – 46E01-0A0)	1.480 – 1.484 mm (0.0583 – 0.0584 in)
Black (12164 – 46E01-0B0)	1.484 – 1.488 mm (0.0584 – 0.0586 in)
Brown (12164 – 46E01-0C0)	1.488 – 1.492 mm (0.0586 – 0.0587 in)
Yellow (12164 – 46E01-0D0)	1.492 – 1.496 mm (0.0587 – 0.0589 in)

**CAUTION**

The bearings must be replaced as a set.

Ⓐ Color code

**CONROD AND BEARING REASSEMBLY**

- When fitting the bearings to the bearing cap and conrod, be sure to fix the stopper part Ⓐ first and press in the other end.

**CAUTION**

Be sure to clean the conrod big end.

- Apply MOLYBDENUM OIL SOLUTION to the crank pin and bearing surface.

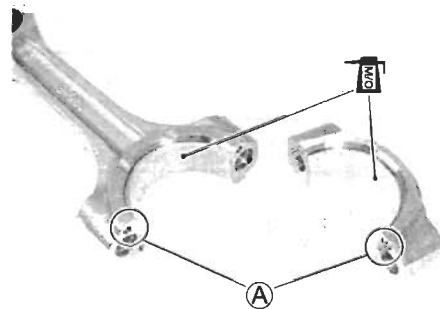
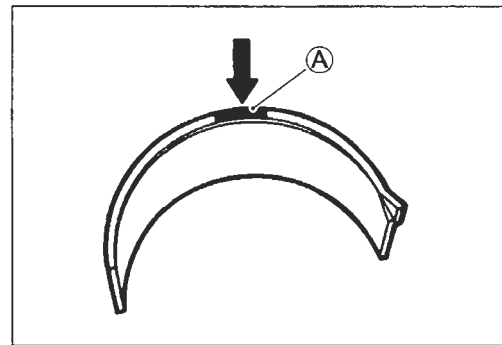
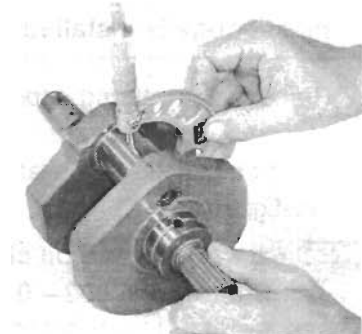
**MOLYBDENUM OIL SOLUTION**

- When fitting the conrods on the crankshaft, make sure that I.D. codes (A) of the conrods face each cylinder intake valve sides.

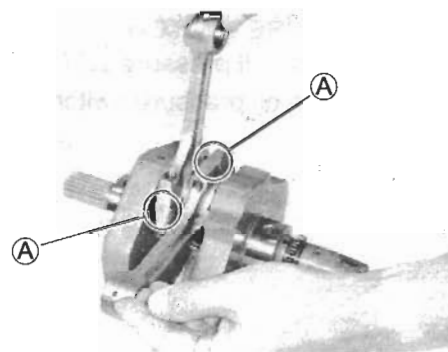

- Apply engine oil to the thread and flange of the bearing cap bolts.
- Tighten the bearing cap bolt as following two steps.

#### Conrod bearing cap bolt

(Initial): 21 N·m (2.1 kgf-m, 15.0 lb-ft)

(Final) : After tightening the bolts to the above torque, tighten them 1/4 of a turn (90 °).

- Apply engine oil to the conrod big end side surfaces.
- Check the conrod movement for smooth turning.

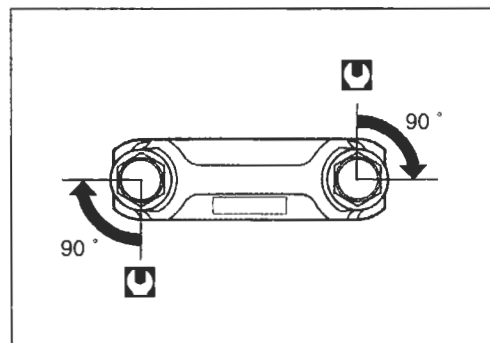

## CRANKCASE

### OIL PRESSURE REGULATOR

- Remove the oil pressure regulator ①.

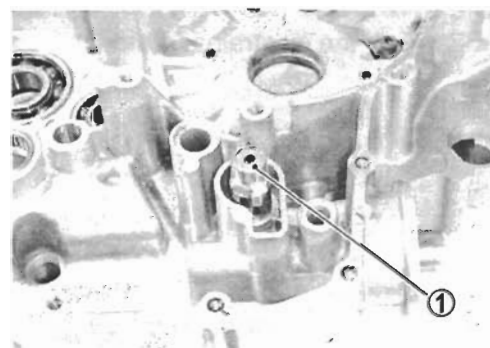

- Check the operation of the oil pressure regulator by pushing on the piston with a proper bar. If the piston does not operate, replace the oil pressure regulator with a new one.

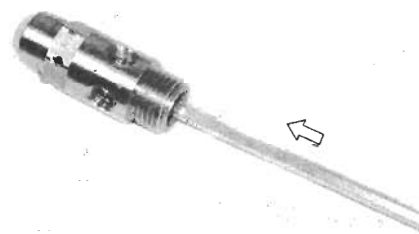

- Tighten the oil pressure regulator to the specified torque.

#### Oil pressure regulator: 27 N·m (2.7 kgf-m, 19.5 lb-ft)

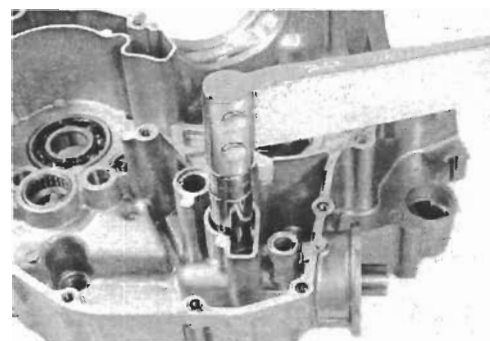

### OIL PRESSURE SWITCH

- Remove the oil pressure switch ①.
- Inspect the oil pressure switch. (☞ 8-34)

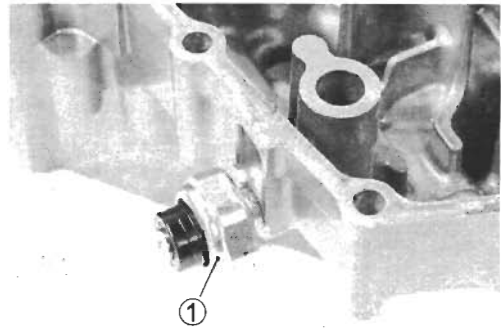

- Apply SUZUKI BOND to the thread part of the oil pressure switch ① and tighten it to the specified torque.

**1207B** 99104-31140: SUZUKI BOND "1207B" (USA)  
99000-31140: SUZUKI BOND "1207B" (Others)

**🔧** Oil pressure switch: 13 N·m (1.3 kgf·m, 9.5 lb·ft)

#### NOTE:

*Be careful not to apply SUZUKI BOND to the hole of the thread end.*

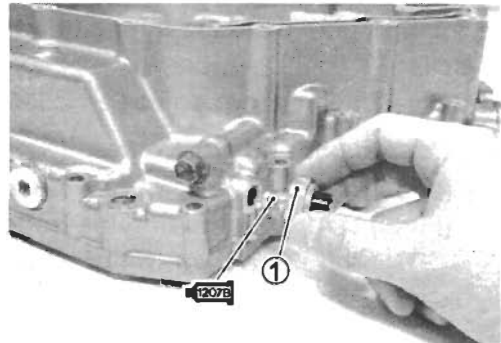

### OIL STRAINER

- Remove the oil strainer plate ①.

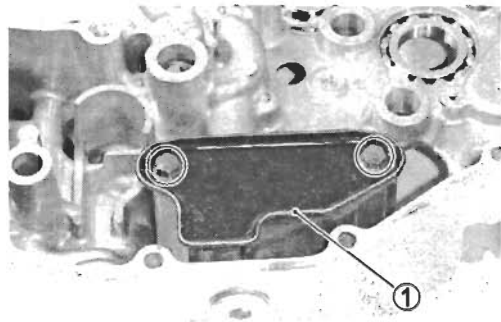

- Remove the oil strainer ②.

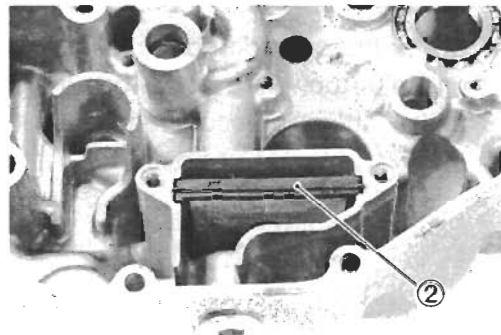

- Clean the oil strainer with a compressed air.

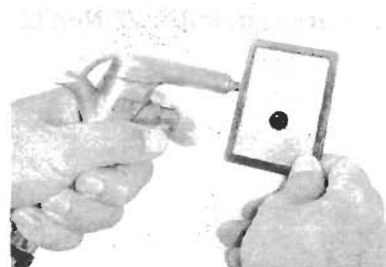

- Install the oil strainer ③.

**NOTE:**

Fit the projection ① of the oil strainer ③ in the concave portion of the crankcase.

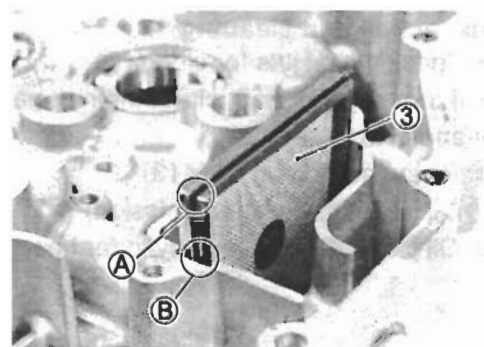

- Install the oil strainer plate ② and tighten the oil strainer plate screw to the specified torque.

 Oil strainer plate screw: 10 N·m (1.0 kgf-m, 7.0 lb-ft)

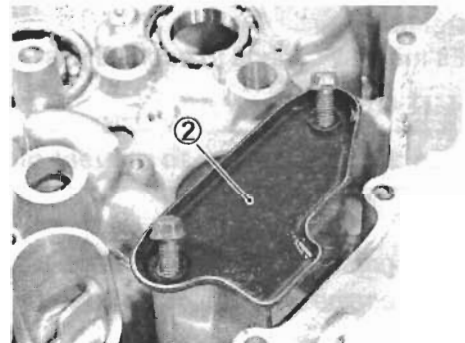

### OIL JET Removal

- Remove the oil jets ①, ② from the left and right crankcase halves.

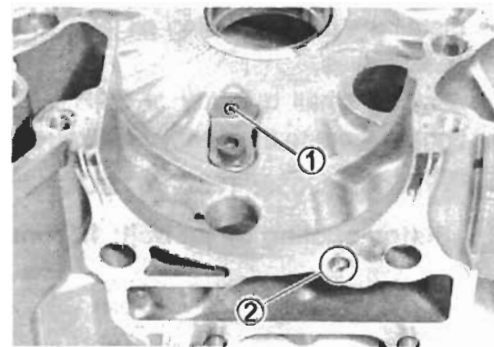

- Remove the oil seal ③ and oil gallery plug ④.

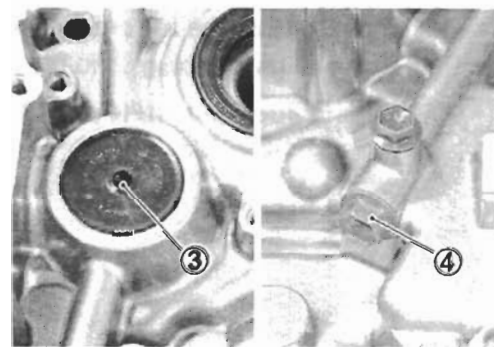

- Remove the oil jet ⑤ from left crankcase half.

**NOTE:**

If it is difficult to remove the oil jet, use a sting.

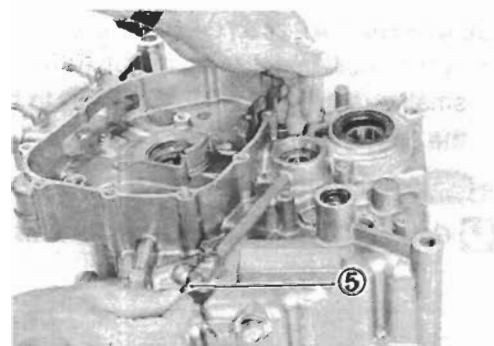

**Inspection and cleaning**

- Check the oil jets for clogging.
- If they are clogged, clean their oil passage with a proper wire and compressed air.

- ① Piston cooling oil jet (#13)
- ② Oil jet (#14) (For transmission)
- ③ Oil jet (#14) (For each cylinder head)

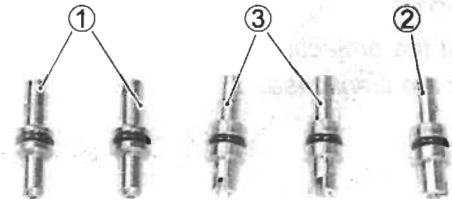
**Installation**

- Fit the new O-rings to each oil jets.

**CAUTION**

**Use the new O-rings to prevent oil leakage.**

**NOTE:**

- \* Apply grease to the O-rings when installing the oil jets.
- \* Apply engine oil to the oil jet holes on the crankcase.

- Install the piston cooling oil jets ① to the left and right crankcase halves.
- Apply a small quantity of THREAD LOCK to the bolts and tighten them to the specified torque.

 **1342 99000-32050: THREAD LOCK "1342"**

 **Piston cooling oil jet bolt: 10 N·m (1.0 kgf-m, 7.0 lb-ft)**

- Push the oil jet into the left crankcase half until it stops.
- Tighten the oil gallery plug ② to the specified torque.

 **Oil gallery plug (M8): 18 N·m (1.8 kgf-m, 13.0 lb-ft)**

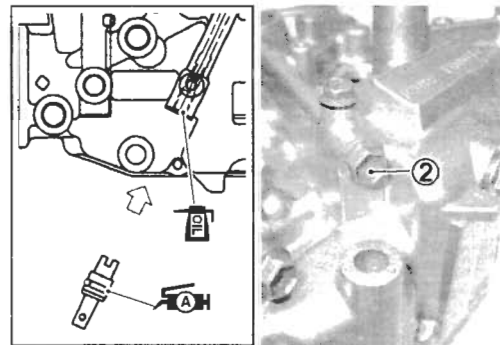
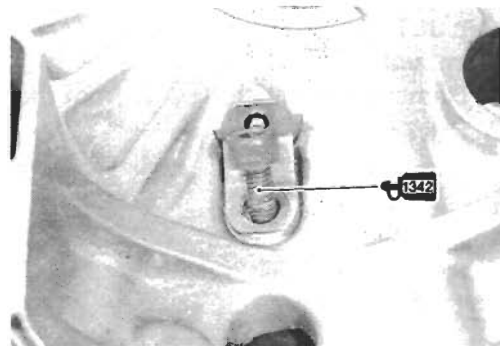
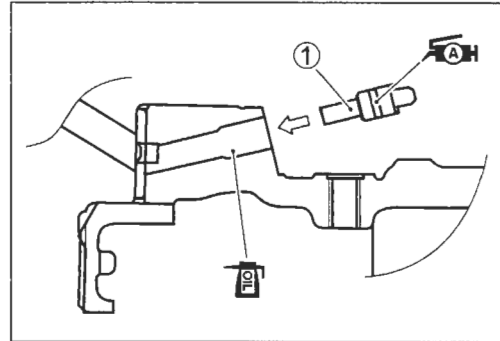
**GEARSHIFT ARM STOPPER**

- When installing the gearshift arm stopper bolt ①, apply a small quantity of THREAD LOCK to its thread and tighten it to the specified torque.

 **1303 99000-32030: THREAD LOCK SUPER "1303"**

 **Gearshift arm stopper bolt: 19 N·m (1.9 kgf-m, 13.5 lb-ft)**

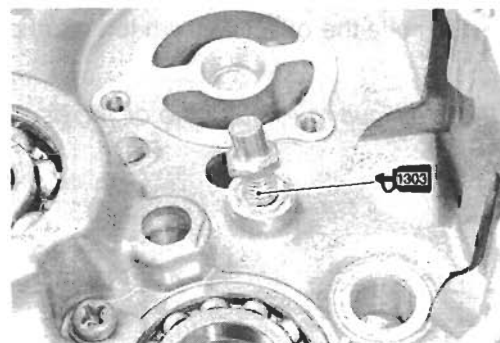

## CRANKSHAFT JOURNAL BEARING

### INSPECTION

- Inspect the crankshaft journal bearings for any damage.
- If any, replace them with a specified set of bearings.

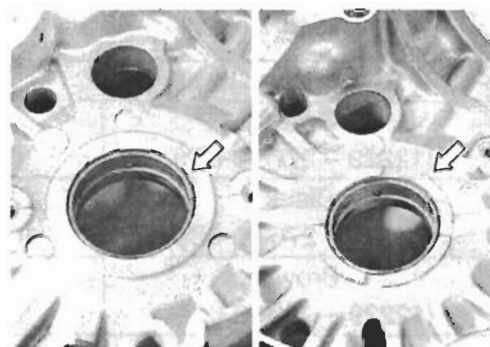

### SELECTION

- Inspect the crankshaft journal for any damage.
- Measure the crankshaft journal O.D. with the special tool.

#### **DATA** Crankshaft journal O.D.

Standard: 41.985 – 42.000 mm  
(1.6529 – 1.6535 in)

**TOOL** 09900-20202: Micrometer (25 – 50 mm)

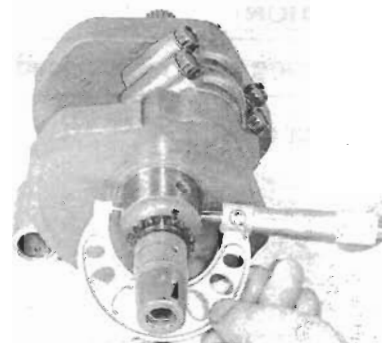

- Select the specified bearings from the crankcase bore I.D. code. The crankcase bore I.D. code ① “A”, “B” or “C”, is stamped on the inside of each crankcase half.

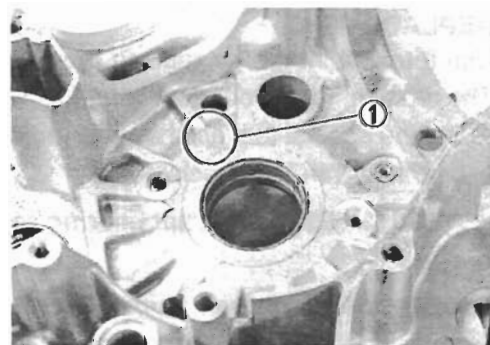

#### Bearing selection table

	Crankcase I.D. ①		
	A	B	C
Bearing color	Green	Black	Brown

#### **DATA** Crank shaft journal I.D.

I.D. code ①	I.D. specification
A	46.000 – 46.006 mm (1.8110 – 1.8113 in)
B	46.006 – 46.012 mm (1.8113 – 1.8115 in)
C	46.012 – 46.018 mm (1.8115 – 1.8117 in)

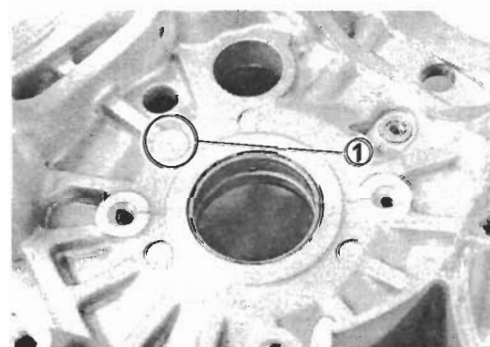



**DATA** Bearing thickness

Color (Part No.)	Thickness
Green (12229 - 27G00-0A0)	1.996 - 1.999 mm (0.0786 - 0.0787 in)
Black (12229 - 27G00-0B0)	1.999 - 2.002 mm (0.0787 - 0.0788 in)
Brown (12229 - 27G00-0C0)	2.002 - 2.005 mm (0.0788 - 0.0789 in)

**CAUTION**

**Bearing must be replaced as a set.**

Ⓐ Color code

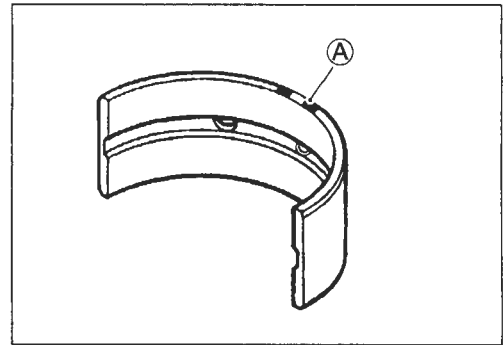

**REPLACEMENT**

Use the special tool to replace the crankshaft journal bearings. The replacement procedure is as follows.

- Set the special tool as shown to remove the crankshaft journal bearings with the special tool.

**TOOL 09913-60221: Journal bearing remover/installer**

**NOTE:**

*Remove the crankshaft journal bearings in only one direction, from inside to outside of each crankcase half.*

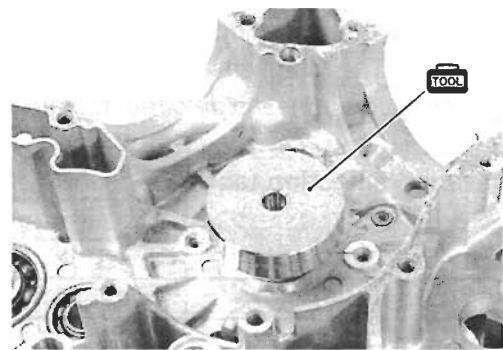

- Gradually press out the bearing with the special tool by using the hand-press.

**CAUTION**

The removed bearings must be replaced with new ones.

- ① Hand-press
- ② Crankcase
- ③ Bearing

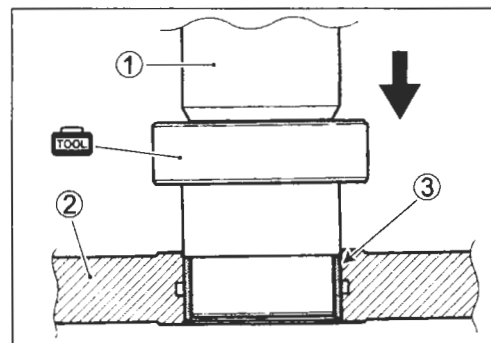
**NOTE:**

Using the hand-press is recommended to remove the crankshaft journal bearings. However, the crankshaft journal bearings can be removed by using with the following special tools.

- TOOL** 09924-84510: Bearing installer set
- 09910-20116: Conrod holder
- 09913-60221: Journal bearing remover/installer

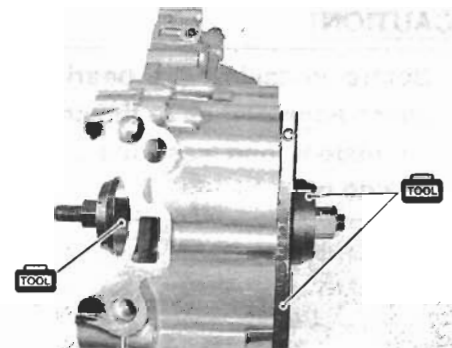

- Set the specified crankshaft journal bearings to the special tool.

**CAUTION**

- \* Before setting the bearing, apply enough engine oil to the special tool and bearings.
- \* When setting the bearing, align the bearing side with the engraved line (A) and also the bearing end with the mating surface of the special tool.

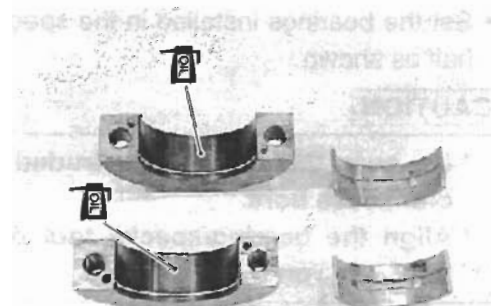
**NOTE:**

The upper and lower bearings are same.

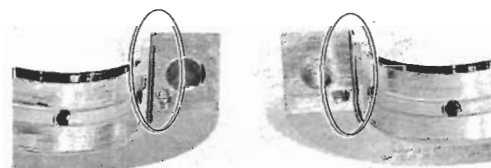
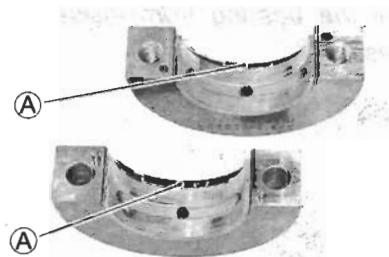

- Tighten the special tool bolts to the specified torque.

**Special tool bolt: 23 N·m (2.3 kgf-m, 16.5 lb-ft)**

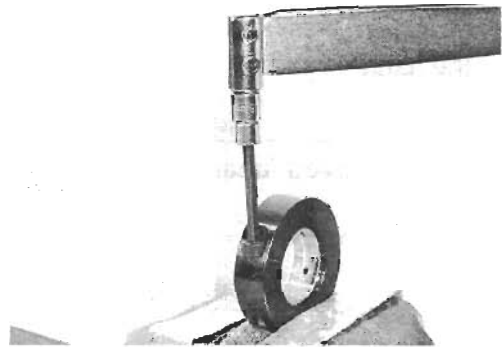

#### CAUTION

Before installing the bearings, lightly shave off the sharp edge part (A) of the crankcase chamfer by using an oilstone and wash the crankcase bore with enough engine oil.

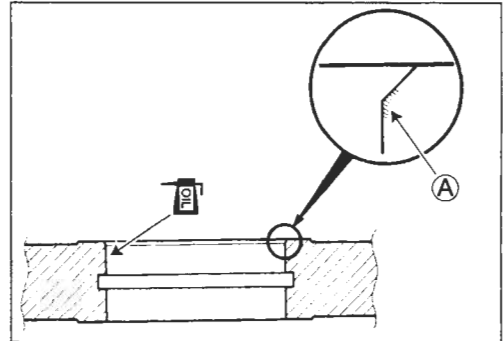

- Set the bearings installed in the special tool to the crankcase half as shown.

#### CAUTION

- \* Be sure the bearing protruded side (B) faces the crankcase bore.
- \* Align the bearing/special tool mating surface with the line (C) on the crankcase.

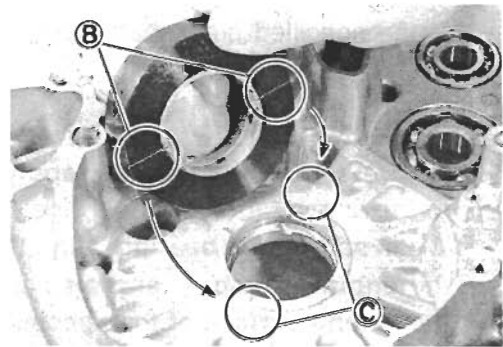

#### NOTE:

Install the bearing from inside to outside of each crankcase halves.

- Apply enough engine oil to the special tool and the bearings and then set the special tool carefully.
- Gradually press ① in the bearing ② into the main journal bore by using the hand-press until the special tool ③ contacts the special tool ④.

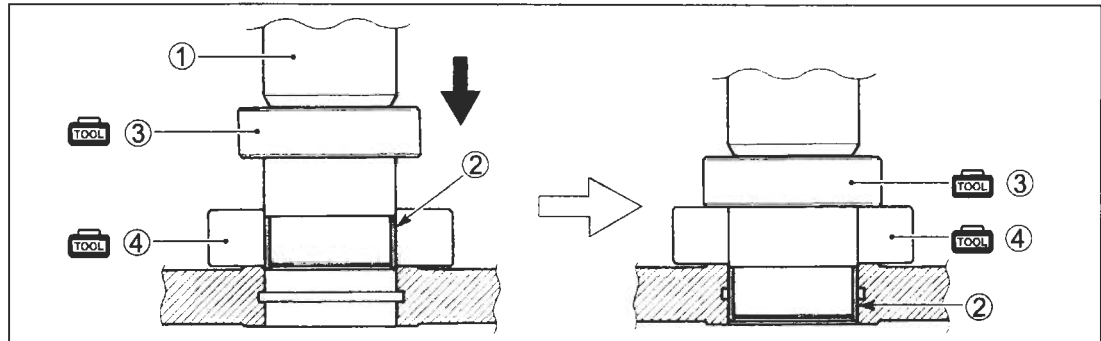
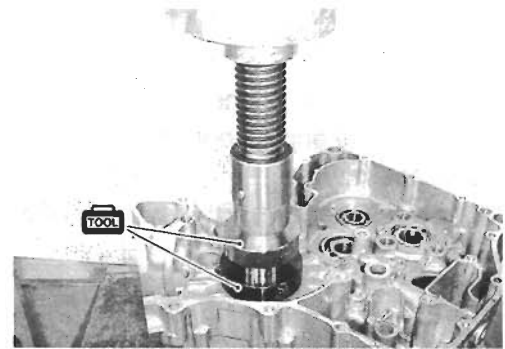
**NOTE:**

Using the hand-press is recommended to install the crankshaft journal bearings. However, the crankshaft journal bearings can be installed by using the following special tools.

- TOOL 09924-84510: Bearing installer set**
- 09910-20116: Conrod holder**
- 09913-60221: Journal bearing remover/installer**

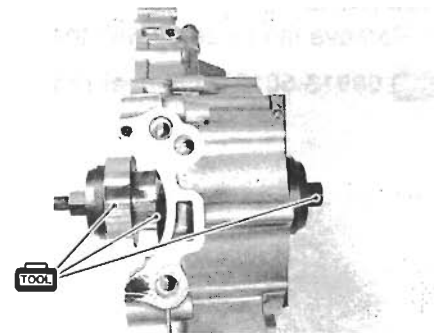

- After installing the bearings, check the bearing surface for any scratch or damage.

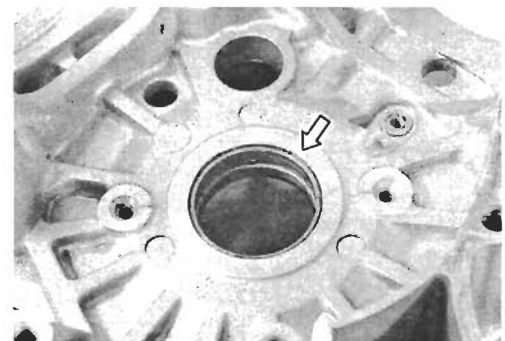
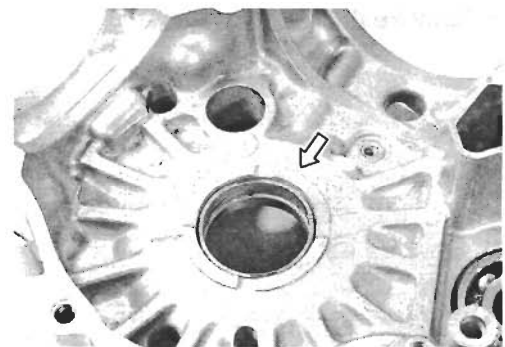

## CRANKCASE BEARING AND OIL SEAL

### INSPECTION

Rotate the bearing inner race by finger to inspect for abnormal play  $\textcircled{A}$ , noise and smooth rotation while the bearings are in the crankcase.

Replace the bearing with new ones, if there is anything unusual.

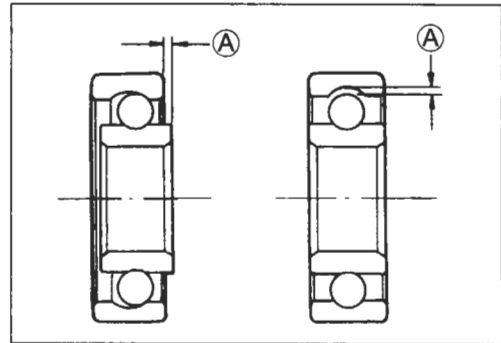

Inspect the oil seals for any damage.

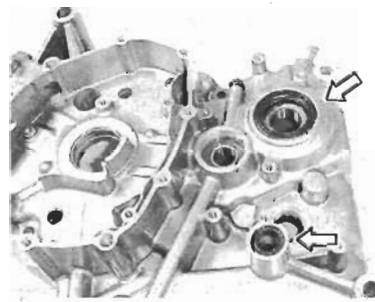

### REMOVAL

- Remove the oil seals with the special tool or a suitable bar.

 **09913-50121: Oil seal remover**

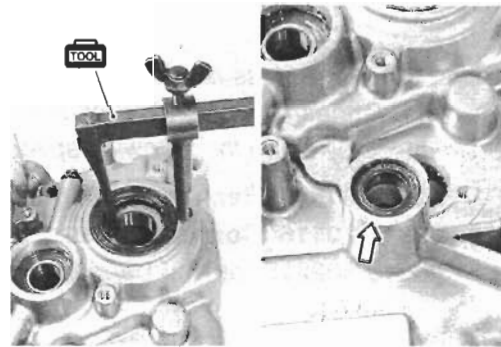

- Remove the bearing retainers  $\textcircled{1}$ .



- Remove the crankcase bearings by with the special tool.

**TOOL 09921-20240: Bearing remover set**

**NOTE:**

Select the suitable size attachment as following illustration.

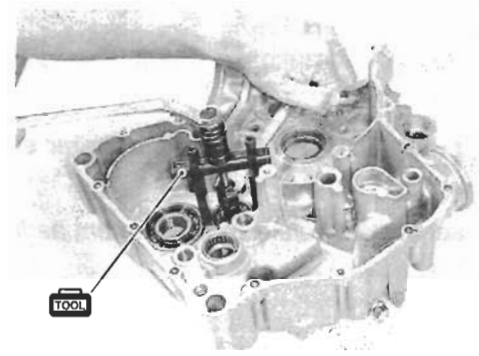

### Bearing remover attachment

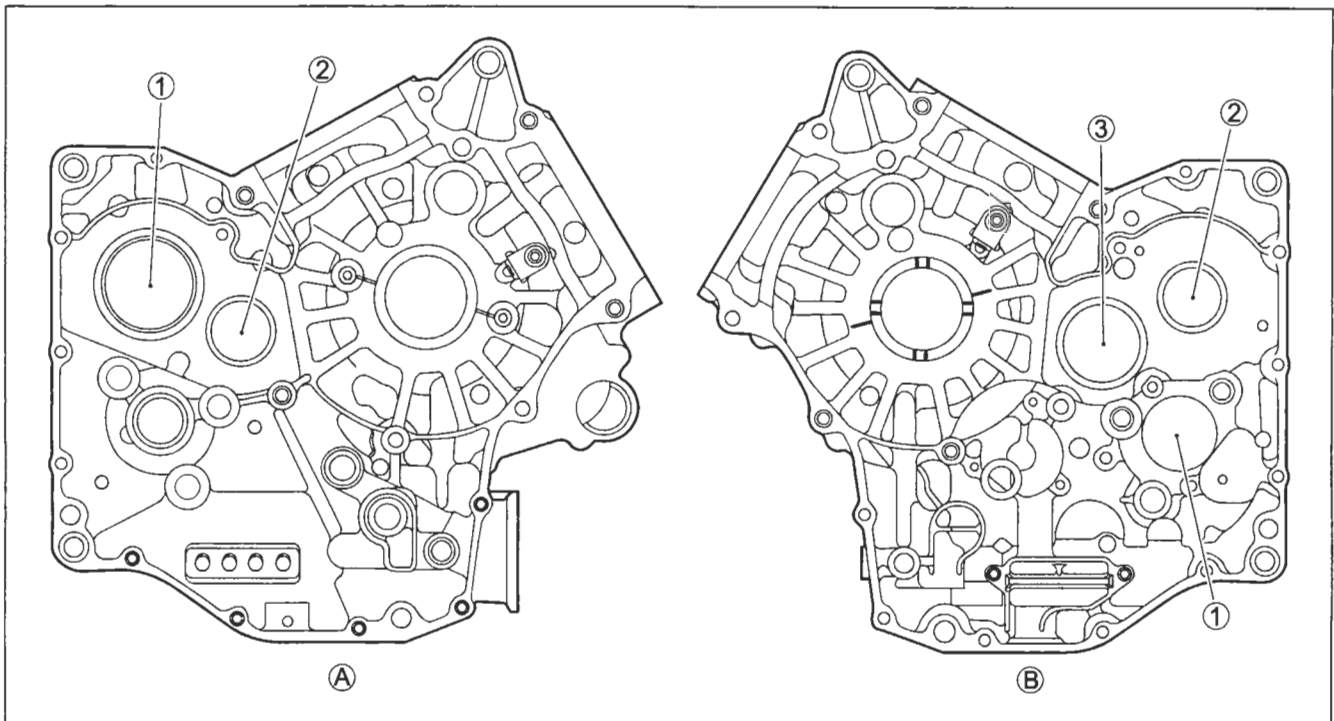

①  $\phi 25$  mm    ②  $\phi 17$  mm    ③  $\phi 20$  mm    A Left crankcase    B Right crankcase

**INSTALLATION**

- Install the crankcase bearings and oil seals with the special tool.

**TOOL** 09913-70210: Bearing installer set

**NOTE:**

Select the suitable size attachment as following illustration.

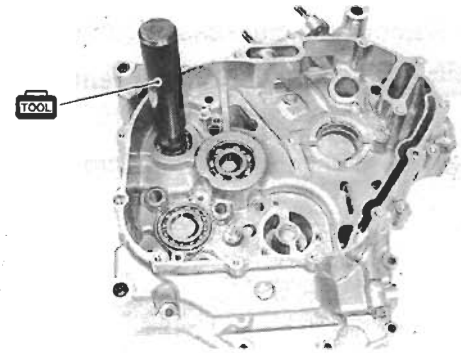

**Bearing installer attachment**

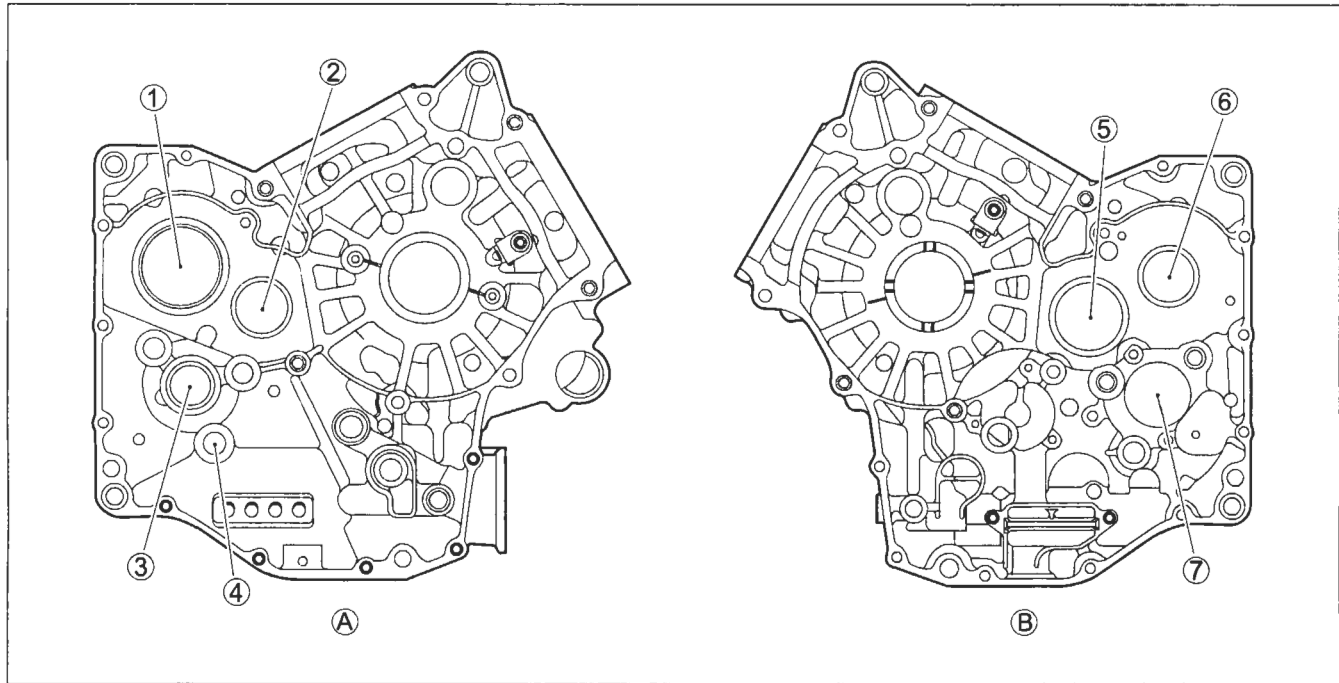

	<b>Bearing</b>	<b>Oil seal</b>
①	φ 62 mm	φ 52 mm
②	φ 40 mm	φ 35 mm
③	φ 32 mm	—
④	—	φ 22 mm
⑤	φ 52 mm	—
⑥	φ 40 mm	—
⑦	φ 47 mm	—

Ⓐ Left crankcase    Ⓑ Right crankcase

- Apply SUZUKI SUPER GREASE to the oil seal lip.

**TOOL** 99000-25030: SUZUKI SUPER GREASE "A" (USA)  
 99000-25010: SUZUKI SUPER GREASE "A" (Others)

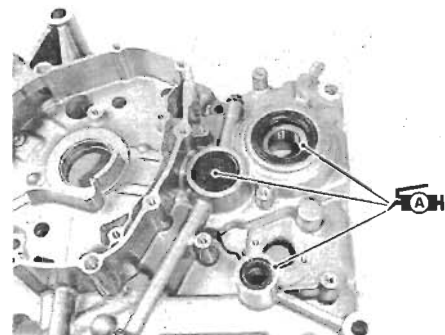

## CLUTCH

### CLUTCH DRIVE PLATES

#### NOTE:

Wipe off engine oil from the clutch drive plates with a clean rag.

- Measure the thickness of drive plates with a vernier calipers.
- If each drive plate is not within the standard range, replace it with a new one.

#### **DATA** Drive plate thickness

Standard: 2.92 – 3.08 mm (0.115 – 0.121 in)

#### **TOOL** 09900-20102: Vernier calipers

- Measure the claw width of drive plates with a vernier calipers.
- Replace the drive plates found to have worn down to the limit.

#### **DATA** Drive plate claw width

Service Limit: 11.5 mm (0.453 in)

#### **TOOL** 09900-20102: Vernier calipers

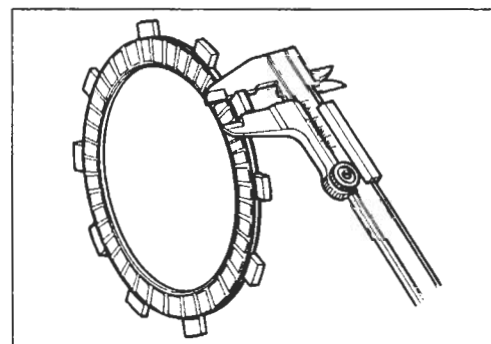
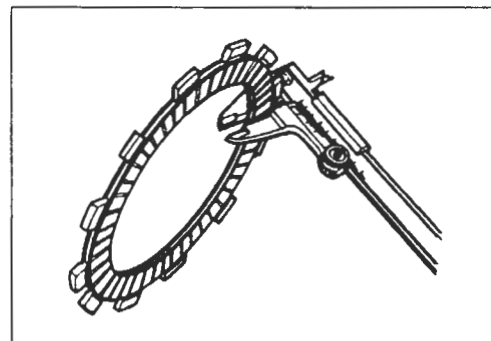

### CLUTCH DRIVEN PLATES

#### NOTE:

Wipe off engine oil from the clutch driven plates with a clean rag.

- Measure each driven plate for distortion with a thickness gauge and surface plate.
- Replace driven plates which exceed the limit.

#### **DATA** Driven plate distortion

Service Limit: 0.10 mm (0.004 in)

#### **TOOL** 09900-20803: Thickness gauge

### CLUTCH SPRING

- Measure the free length of each coil spring with a vernier calipers, and compare the length with the specified limit.
- Replace all the springs if any spring is not within the limit.

#### **DATA** Clutch spring free length

Service Limit: 50.5 mm (1.99 in)

#### **TOOL** 09900-20102: Vernier calipers

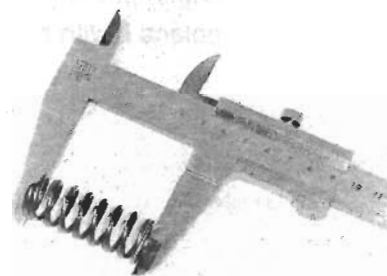
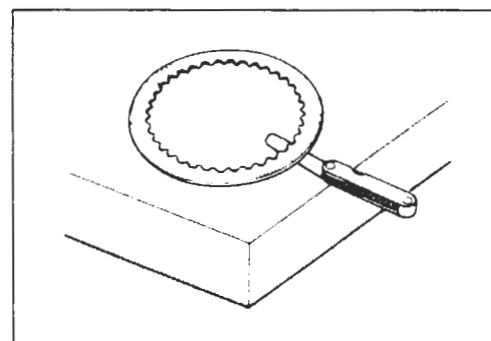



**CLUTCH BEARING INSPECTION**

Smooth engagement and disengagement of the clutch depends on the condition of this bearing.

Inspect the clutch release bearing for any abnormality, particularly cracks, to decide whether it can be reused or should be replaced.

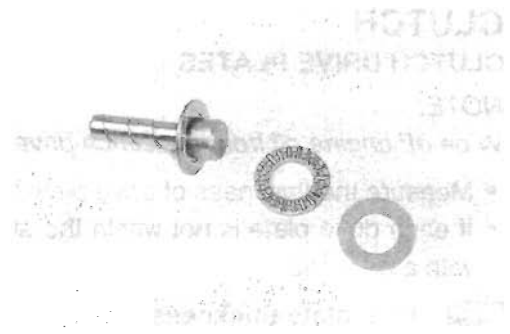
**CLUTCH SLEEVE HUB/PRIMARY DRIVEN GEAR ASSEMBLY**

Inspect the slot of the clutch sleeve hub and primary driven gear assembly for damage or wear caused by the clutch plates.

If necessary, replace it with a new one.

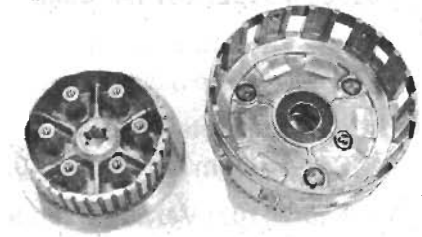
**PRIMARY DRIVEN GEAR ASSEMBLY DISASSEMBLY**

- Remove the snap ring ①.
- Remove the oil pump drive gear ② and pin.

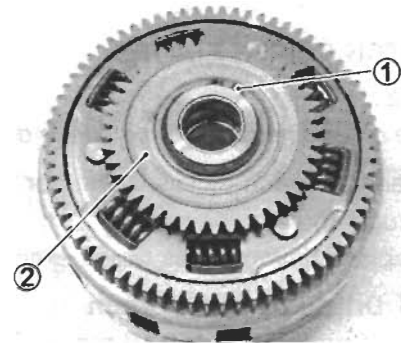
**INSPECTION**

Inspect the primary driven gear bushing for any damage. Inspect the spring of primary driven gear for any damages. If necessary, replace it with a new one.

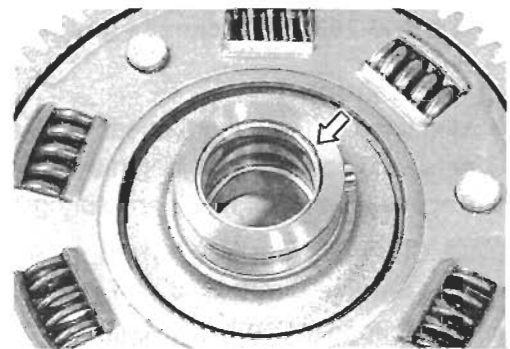
**REASSEMBLY**

- Install the pin ①.
- Align the oil pump drive gear slot (A) with the pin ①.

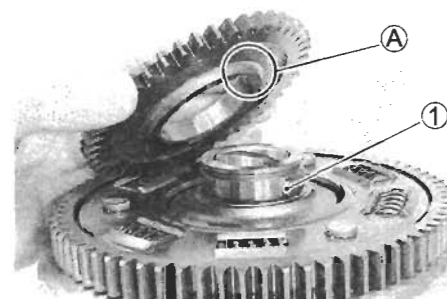

- Install the snap ring ②.

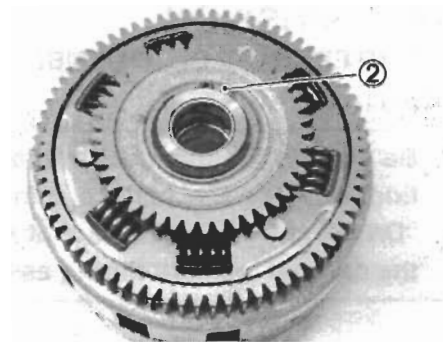

## GEARSHIFT SHAFT/GEARSHIFT ARM DISASSEMBLY

- Remove the following parts from the gearshift shaft/gearshift arm.

- |                                 |                             |
|---------------------------------|-----------------------------|
| ① Washer                        | ⑤ Washer                    |
| ② Snap ring                     | ⑥ Plate return spring       |
| ③ Gearshift shaft return spring | ⑦ Gearshift cam drive plate |
| ④ Snap ring                     |                             |

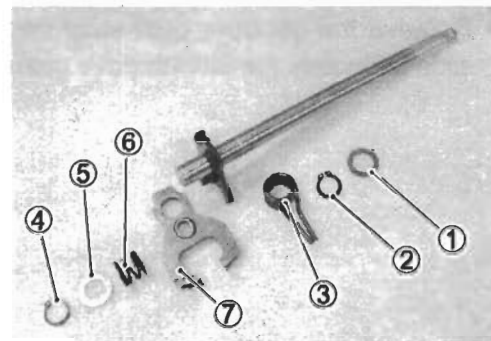

## INSPECTION

Check the gearshift shaft/gearshift arm for wear or bend.  
Check the return springs for damage or fatigue.

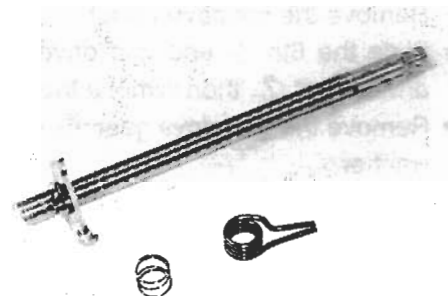

## REASSEMBLY

- Install the following parts to the gearshift shaft/gearshift arm as shown in the right illustration.

- |                                 |                             |
|---------------------------------|-----------------------------|
| ① Washer                        | ⑤ Washer                    |
| ② Snap ring                     | ⑥ Plate return spring       |
| ③ Gearshift shaft return spring | ⑦ Gearshift cam drive plate |
| ④ Snap ring                     |                             |

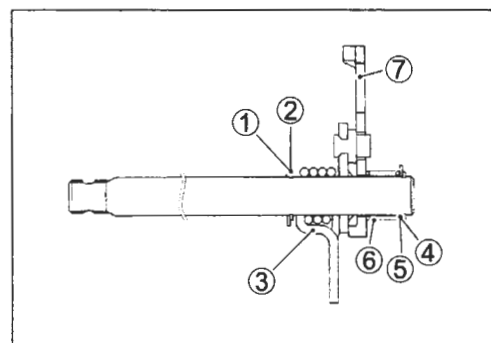

## NOTE:

When installing the gearshift shaft return spring ③, position the stopper ⑧ of the gearshift arm between the shaft return spring ends ⑨.

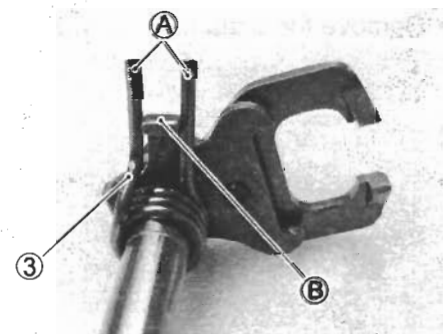

## TRANSMISSION

### COUNTERSHAFT DISASSEMBLY

#### CAUTION

Be sure to identify each removed part as to its location, and lay the parts out in groups designated as "Drive" and "Driven", so that each will be restored to the original location during assembly.

- Remove the 6th drive gear snap ring ① from its groove and slide it towards the 3rd/4th drive gears ②.

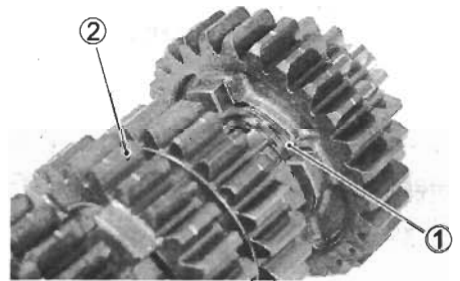

- Remove the concaved washer ③ and O-ring ④.
- Slide the 6th ⑤ and 2nd drive gears ⑥ toward the 3rd/4th drive gears ⑦, then remove the 2nd drive gear circlip ⑧.
- Remove the 2nd drive gear ⑥, 6th drive gear ⑤, bushing and washer.

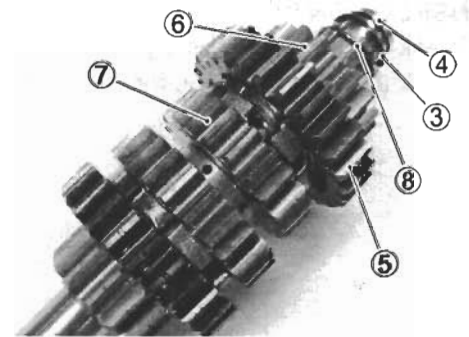

- Remove the snap ring ⑨ and 3rd/4th drive gears ⑩.

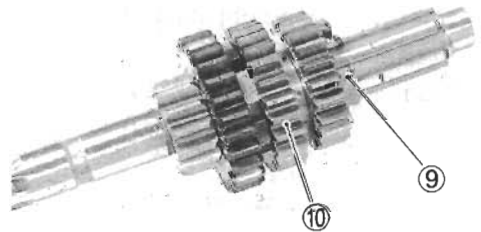

- Remove the snap ring ⑪, washer ⑫ and 5th drive gear ⑬.

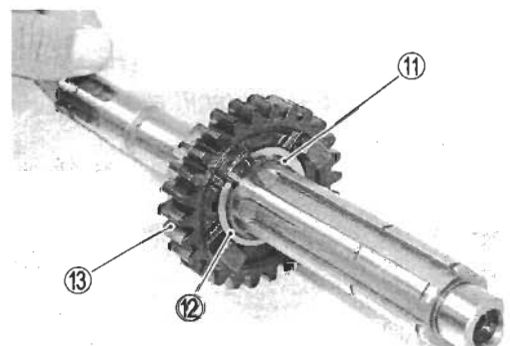

- Remove the 5th drive gear bushing ⑭.

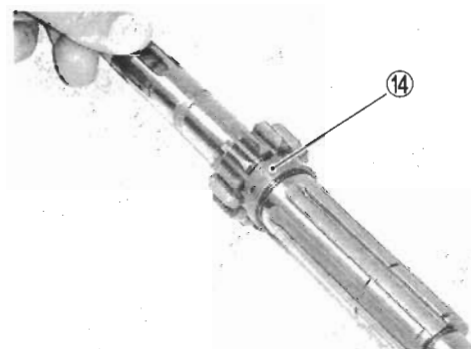

### DRIVESHAFT DISASSEMBLY

- Remove the washer ① and 1st driven gear ②.

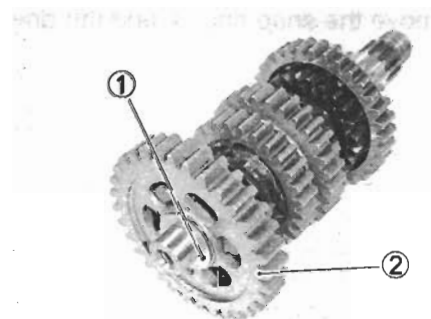

- Remove the 1st driven gear bushing ③, washer ④ and 5th driven gear ⑤.

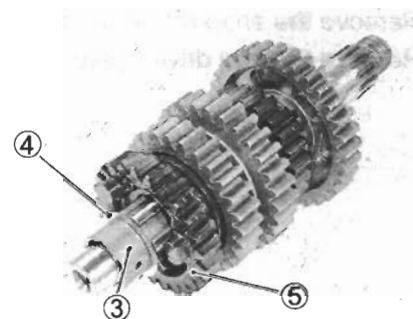

- Remove the snap ring ⑥, washer ⑦ and 4th driven gear ⑧.

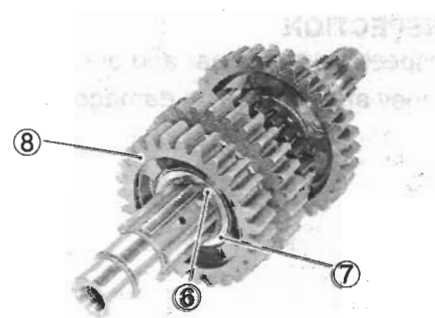

- Remove the 4th driven gear bushing ⑨, lock washers ⑩ and 3rd driven gear ⑪.

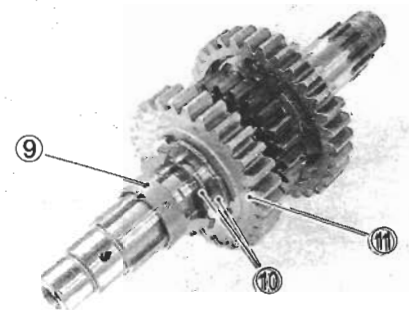

- Remove the 3rd driven gear bushing ⑫ and washer ⑬.

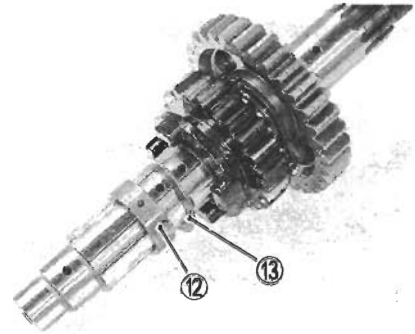

- Remove the snap ring ⑭ and 6th driven gear ⑮.

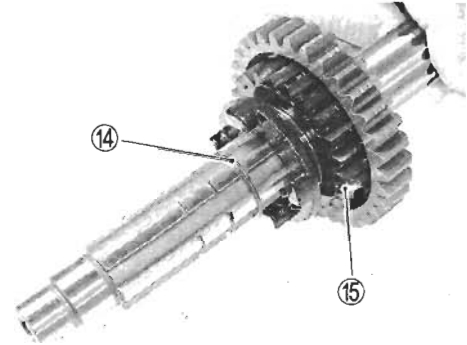

- Remove the snap ring ⑯ and 2nd driven gear bushing ⑰.
- Remove the 2nd driven gear ⑱.

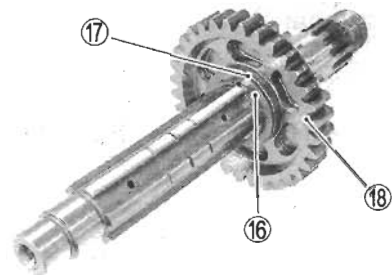

### INSPECTION

Inspect the each gear and bushing for wear and damage.  
If they are found to be damaged, replace them with new ones.



**REASSEMBLY**

Assemble the countershaft and driveshaft in the reverse order of disassembly. Pay attention to the following points:

- Before installing the gears, lightly coat MOLY PASTE or engine oil to the driveshaft and countershaft.

 **99000-25140: SUZUKI MOLY PASTE**

- Before installing the O-ring, apply SUZUKI SUPER GREASE to it.

 **99000-25030: SUZUKI SUPER GREASE "A" (USA)**  
**99000-25010: SUZUKI SUPER GREASE "A" (Others)**

**NOTE:**

- \* Rotate the bushings by hand to inspect for smooth rotation. Replace the bushings if there is anything unusual.

**CAUTION**

- \* Never reuse a snap ring. After a snap ring has been removed from a shaft, it should be discarded and a new snap ring must be installed.
- \* When installing a new snap ring, do not expand the end gap larger than required to slip the snap ring over the shaft.
- \* After installing a snap ring, make sure that it is completely seated in its groove and securely fitted.

**NOTE:**

When reassembling the transmission, attention must be given to the locations and positions of washers and snap rings. The cross sectional view shows the correct position of the gears, bushings, washers and snap rings. (Fig 3-77)

When installing a new snap ring, pay attention to the direction of the snap ring. Fit it to the side where the thrust is as shown in the illustration.

- Ⓐ Thrust
- Ⓑ Sharp edge

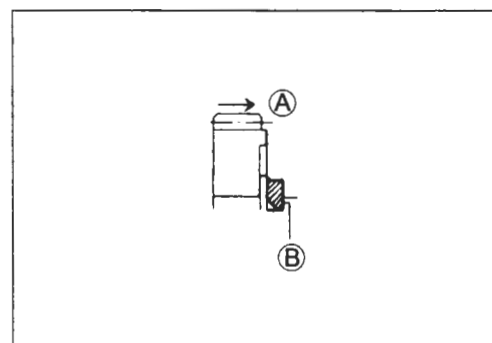

**CAUTION**

When installing the 6th drive gear, 3rd driven gear and 4th driven gear bushings onto the shaft, align the shaft oil hole (A) with the bushing oil hole (B).

- ① 6th drive gear bushing
- ② 3rd driven gear bushing
- ③ 4th driven gear bushing

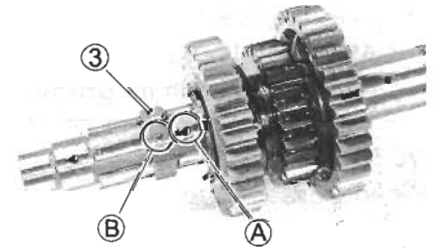
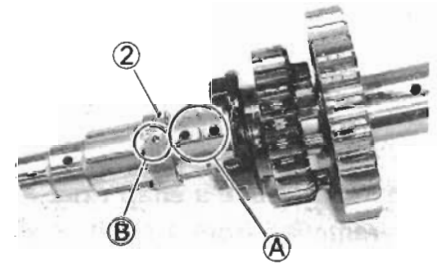
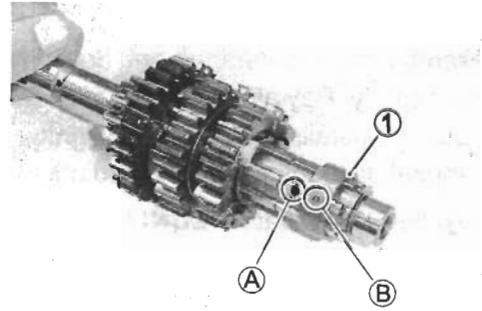

- After installing the 3rd driven gear (4) onto the driveshaft, install lock washer No.2 (5) onto the driveshaft, and position it so it fits into the groove.
- Then, fit lock washer No.1 (6) into lock washer No.2 (5).

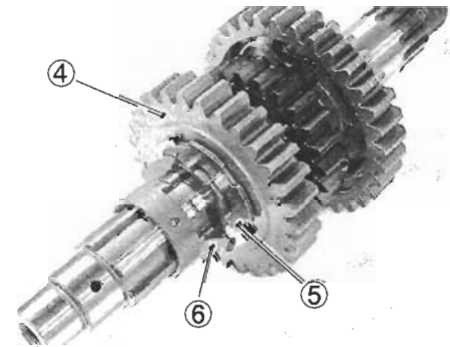

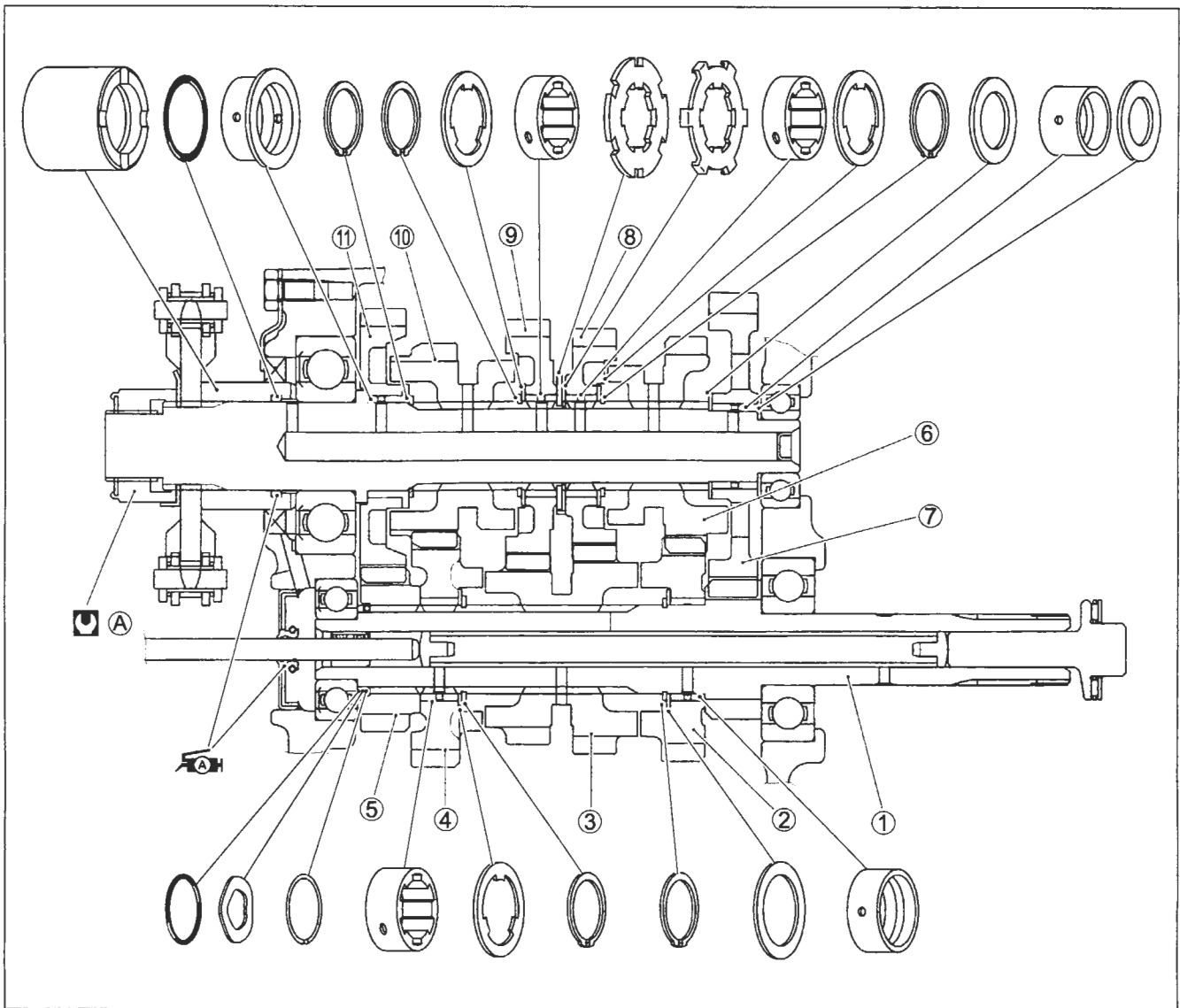

①	1st (Low) drive gear/countershaft	⑦	5th driven gear
②	5th drive gear	⑧	4th driven gear
③	3rd/4th drive gear	⑨	3rd driven gear
④	6th (Top) drive gear	⑩	6th (Top) driven gear
⑤	2nd drive gear	⑪	2nd driven gear
⑥	1st (Low) driven gear	Ⓐ	145 N·m (14.5 kgf·m, 105 lb-ft)



**GEARSHIFT FORK TO GROOVE CLEARANCE**

Using a thickness gauge, check the gearshift fork clearance in the groove of its gear.

The clearance for each gearshift fork plays an important role in the smoothness and positiveness of the shifting action.

**DATA** Shift fork to groove clearance  
Service Limit: 0.50 mm (0.020 in)

**TOOL** 09900-20803: Thickness gauge  
09900-20102: Vernier calipers

If the clearance checked is noted to exceed the limit specified, replace the fork or its gear, or both.

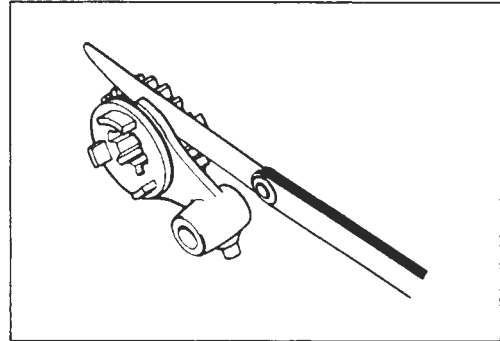
**GEARSHIFT FORK GROOVE WIDTH**

- Measure the gearshift fork groove width using the vernier calipers.

**DATA** Shift fork groove width  
Standard: 5.5 – 5.6 mm (0.217 – 0.220 in)

**TOOL** 09900-20102: Vernier calipers

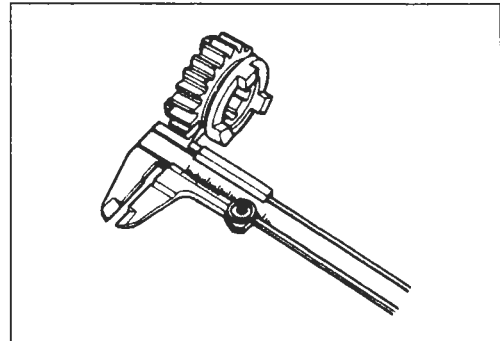
**GEARSHIFT FORK THICKNESS**

- Measure the gearshift fork thickness using the vernier calipers.

**DATA** Shift fork thickness  
Standard: 5.3 – 5.4 mm (0.209 – 0.213 in)

**TOOL** 09900-20102: Vernier calipers

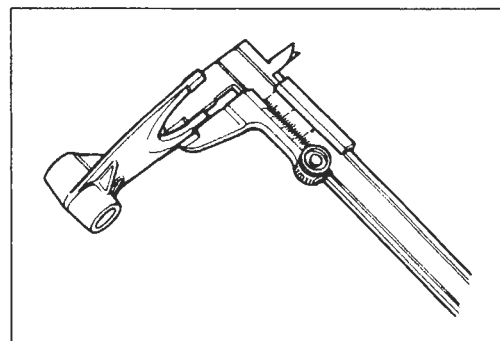

## STARTER CLUTCH

### INSPECTION

Install the starter driven gear onto the starter clutch and turn the starter driven gear by hand to inspect the starter clutch for a smooth movement. The gear turns in one direction only. If a large resistance is felt for rotation, inspect the starter clutch or the starter clutch contacting surface on the starter driven gear for wear and damage.

If they are found to be damaged, replace them with new ones.

Inspect the starter driven gear bearing for any damage.

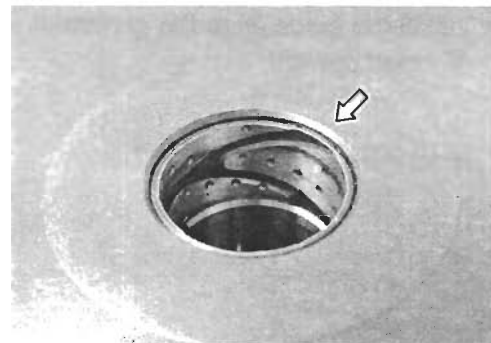
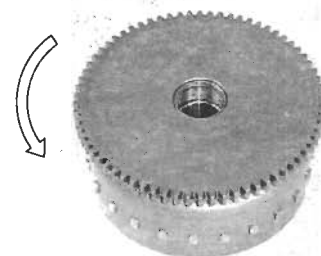

### DISASSEMBLY

- Hold the generator rotor with the special tool and remove the starter clutch bolts.

 09930-44530: Rotor holder

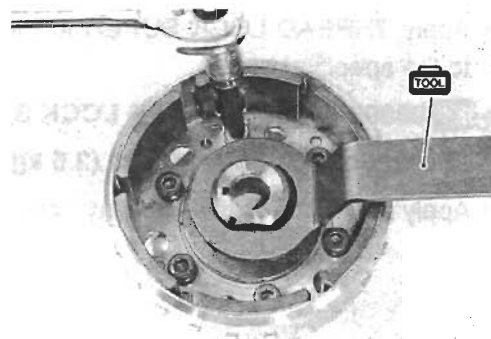

- Remove the one way clutch ① from the guide ②.

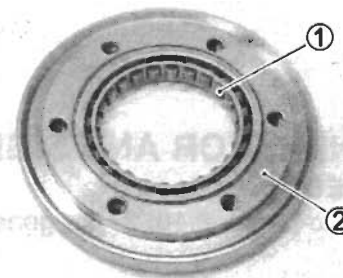

### REASSEMBLY

- When inserting the one-way clutch ① into the guide ②, fit the flange ③ in the step of the guide ②.

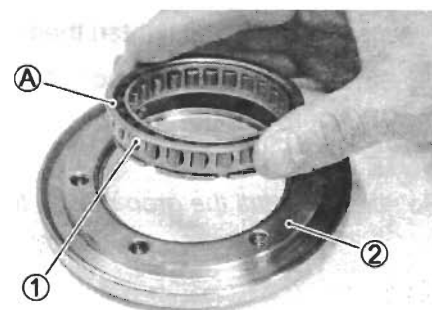

- Be sure to seat the flange (A) of the one way clutch (3) to the guide (4).

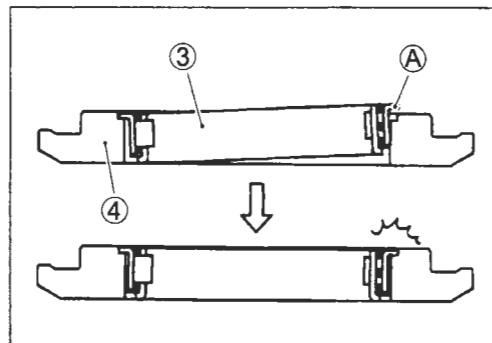

- Install the guide (5) to the generator rotor with the arrow mark (B) faced upward.

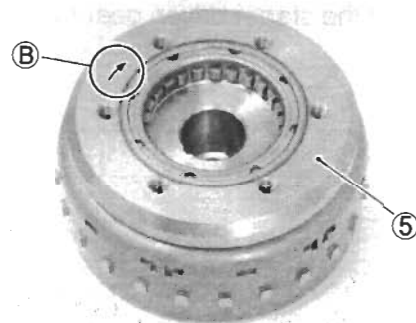

- Apply THREAD LOCK SUPER to the bolts and tighten them to the specified torque.

 **1303 99000-32030: THREAD LOCK SUPER "1303"**

 **Starter clutch bolt: 25 N·m (2.5 kgf-m, 18.0 lb-ft)**

- Apply engine oil to the one way clutch.

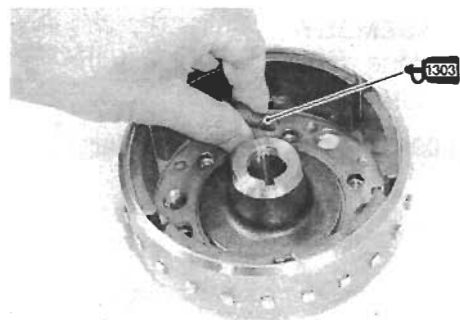

## GENERATOR AND SIGNAL GENERATOR INSPECTION

Refer to pages 8-10, 27 for generator and CKP sensor inspection.

### REASSEMBLY

- When installing the generator starter set bolts (1) and the CKP sensor set bolts (2) tighten them to the specified torque.

 **Generator stator set bolt: 11 N·m (1.1 kgf-m, 8.0 lb-ft)**  
**CKP sensor set bolt: 6.5 N·m (0.65 kgf-m, 4.7 lb-ft)**

### NOTE:

Be sure to install the grommet (A) to the generator cover.

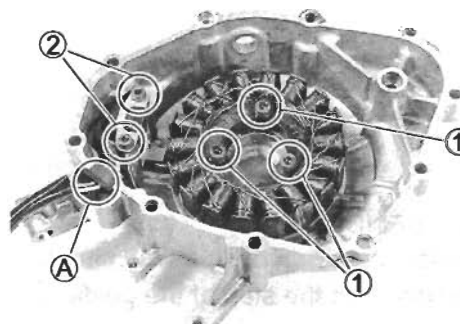

## OIL PUMP

### INSPECTION

Rotate the oil pump by hand and check that it moves smoothly. If it does not move smoothly, replace the oil pump assembly.

### CAUTION

- \* Do not attempt to disassemble the oil pump assembly.
- \* The oil pump is available only as an assembly.

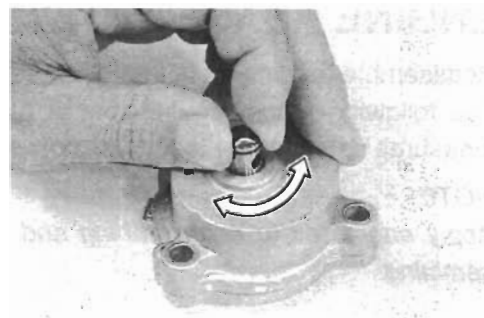

## CLUTCH RELEASE

### INSPECTION

- Check the teeth of clutch release for any damage and wear.

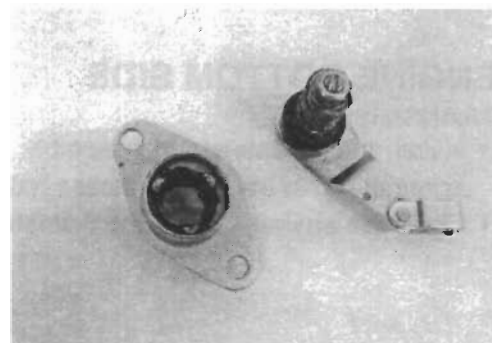

## ENGINE REASSEMBLY

Reassemble the engine in the reverse order of disassembly. The following steps require special attention or precautionary measures should be taken.

### NOTE:

Apply engine oil to each running and sliding part before reassembling.

## ENGINE BOTTOM SIDE TRANSMISSION

- Install the countershaft assembly ① and the driveshaft assembly ② to the left crankcase half.
- Install the washer ③ onto the driveshaft assembly ②.

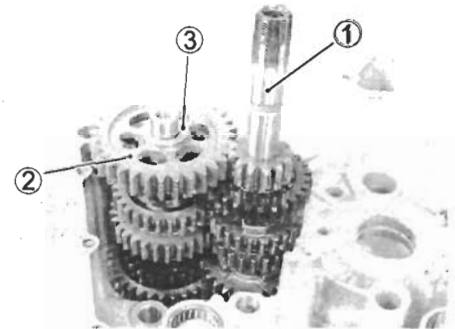

## GEARSHIFT

- Install the gearshift forks ①/②/③, gearshift cam ④ and gearshift fork shafts ⑤.

### NOTE:

Identify the gearshift forks as follows.

- ① For 5th driven gear
- ② For 6th driven gear
- ③ For 3rd/4th drive gear

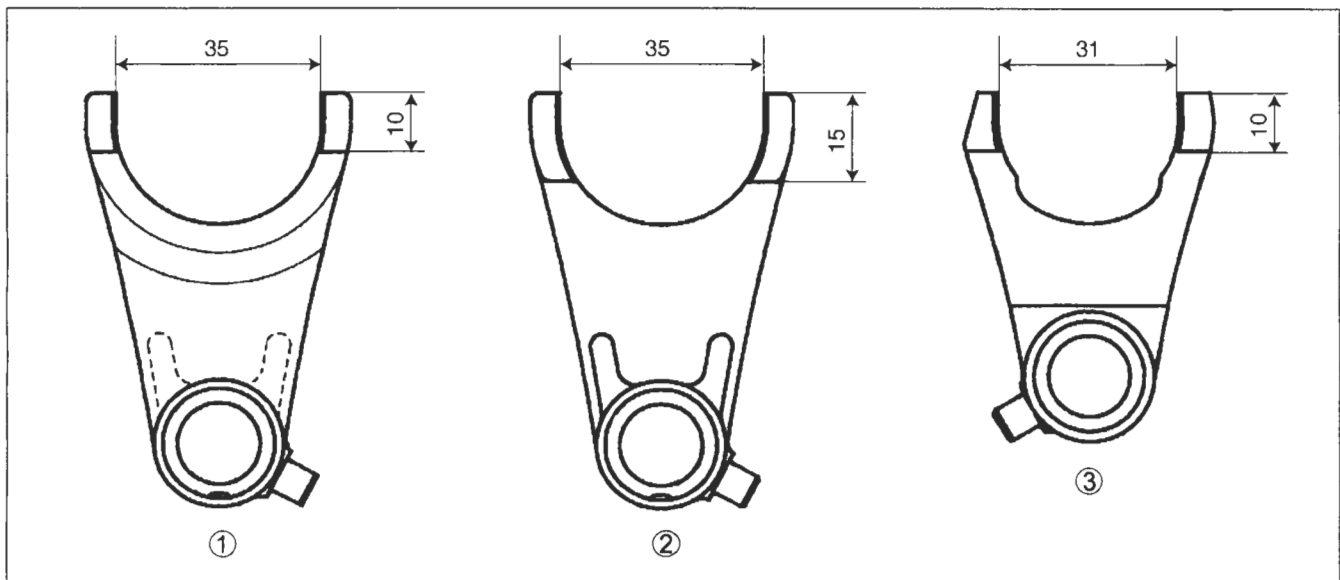
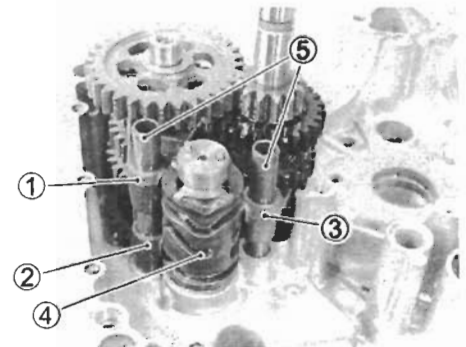

- ① For 5th driven gear
- ② For 6th driven gear
- ③ For 3rd/4th drive gear

**CRANKSHAFT**

- Coat lightly MOLYBDENUM OIL SOLUTION to the crankshaft journal bearings.

**MOLYBDENUM OIL SOLUTION**

- Install the crankshaft into the left crankcase half.

**CAUTION**

Never strike the crankshaft with a plastic hammer when inserting it into the crankcase. It will be easy to install the crankshaft to left crankcase.

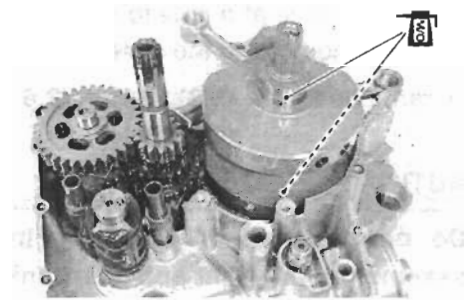
**CRANKCASE**

- Clean the mating surfaces of the left and right crankcase halves.
- Install the O-rings ①, ② and dowel pins ③.
- Apply SUZUKI SUPER GREASE to the O-rings ①, ②.

**99000-25030: SUZUKI SUPER GREASE "A" (USA)**  
**99000-25010: SUZUKI SUPER GREASE "A" (Others)**

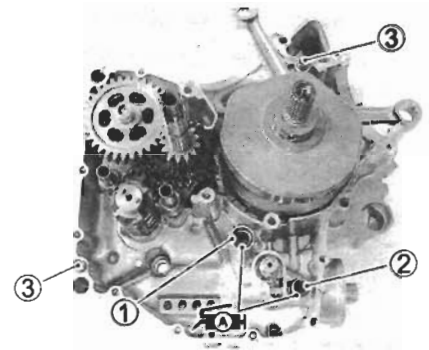

- Apply SUZUKI BOND to the mating surface of the left crankcase.

**99104-31140: SUZUKI BOND "1207B" (USA)**

**99000-31110: SUZUKI BOND "1215" (Others)**

**NOTE:**

Use of SUZUKI BOND is as follows:

- \* Make surfaces free from moisture, oil, dust and other foreign materials.
- \* Spread on surfaces thinly to form an even layer, and assemble the crankcases within few minutes.
- \* Take extreme care not to apply any SUZUKI BOND to the oil hole, oil groove and bearing.
- \* Apply to distorted surfaces as it forms a comparatively thick film.

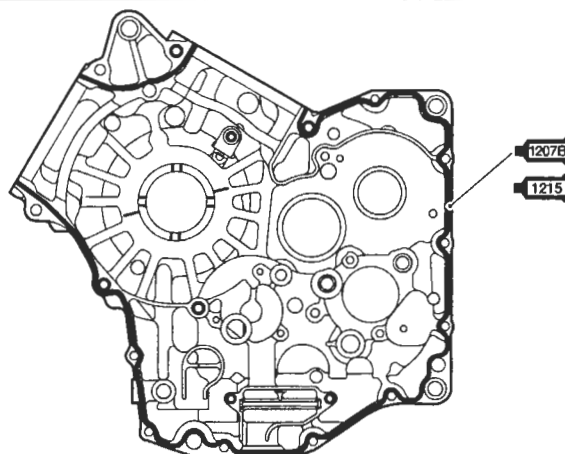

- When securing the right and left crankcase halves, tighten each bolt a little at a time to equalize the pressure. Tighten all the securing bolts to the specified torque values.

**🔧 Crankcase bolt: (M8) 26 N·m (2.6 kgf-m, 19.0 lb-ft)  
(M6) 11 N·m (1.1 kgf-m, 8.0 lb-ft)**

**CAUTION**

**Do not drop the O-ring into the crankcase when assembling the right and left crankcase halves.**

**NOTE:**

- \* After the crankcase bolts have been tightened, check if the crankshaft, the driveshaft and the countershaft rotate smoothly.
- \* Fit the clamp to the bolt © as shown.

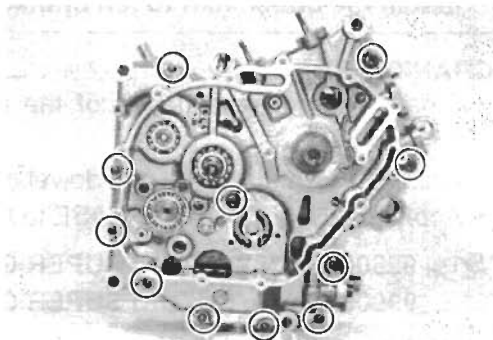
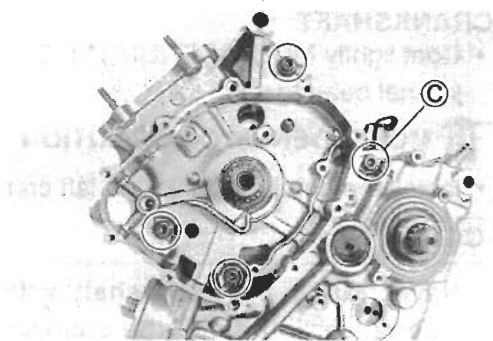

**OIL PLATE**

- Install the oil plate ① and the oil plate bolts tighten to the specified torque.

**🔧 Oil plate bolt: 10 N·m (1.0 kgf-m, 7.0 lb-ft)**

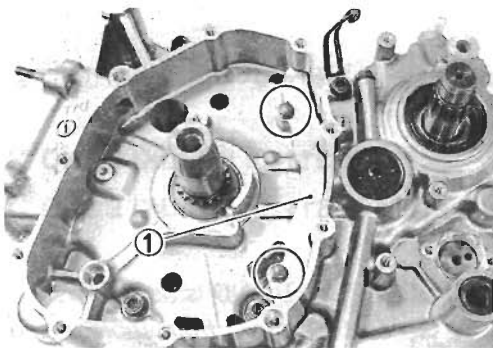

**ENGINE SPROCKET SPACER**

- Install the new O-ring ① into the engine sprocket spacer ②.

**CAUTION**

**Use the new O-ring to prevent oil leakage.**

- Install the engine sprocket spacer ②.

**NOTE:**

- \* The grooved (A) side of the engine sprocket spacer ① must face crankcase side.
- \* Apply SUZUKI SUPER GREASE to the oil seal lip and O-ring.

**🔧 99000-25030: SUZUKI SUPER GREASE "A" (USA)  
99000-25010: SUZUKI SUPER GREASE "A" (Others)**

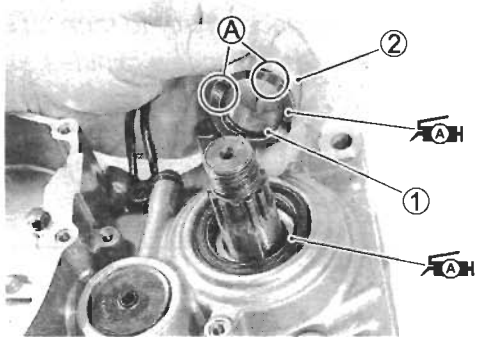

**GEAR POSITION SWITCH**

- Install the gear position switch contacts ① and springs.
- Apply SUZUKI SUPER GREASE to the O-ring ② and then install it onto the gear position switch.

 **99000-25030: SUZUKI SUPER GREASE "A" (USA)**  
**99000-25010: SUZUKI SUPER GREASE "A" (Others)**

- Install the gear position switch ③ as shown.
- Tighten the gear position switch bolt to the specified torque.

 **Gear position switch bolt: 6.5 N·m (0.65 kgf-m, 4.7 lb-ft)**

- Install the drive shaft oil seal retainer ④.

**NOTE:**

*Pass through the gear position switch lead wire under the drive-shaft oil seal retainer.*

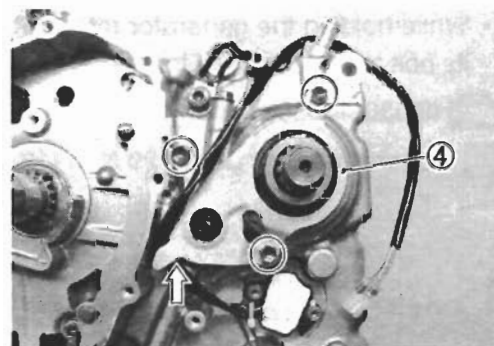
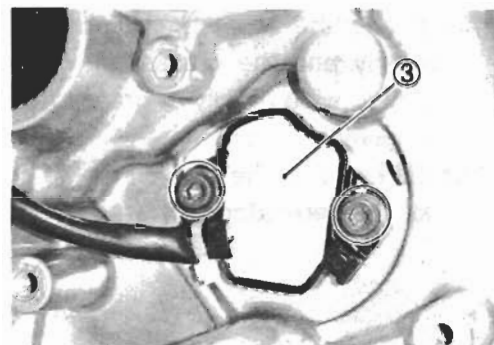
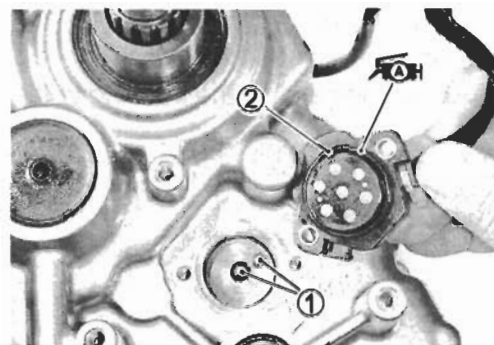
**FRONT CAM CHAIN**

- Install the front cam chain ①.

- Install the cam chain tensioner ②, washer ③ and cam chain tensioner bolt ④.
- Tighten the cam chain tensioner bolt ④ to the specified torque.

 **Cam chain tensioner bolt: 10 N·m (1.0 kgf-m, 7.0 lb-f)**

**NOTE:**

*The front and rear cam chain tensioners are the same.*

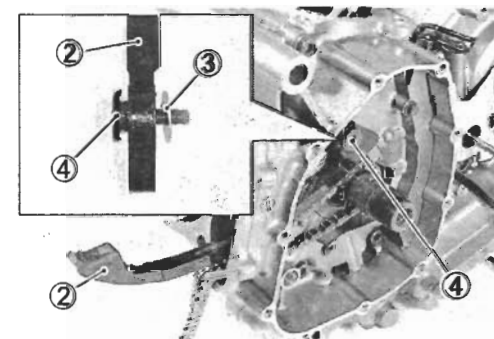
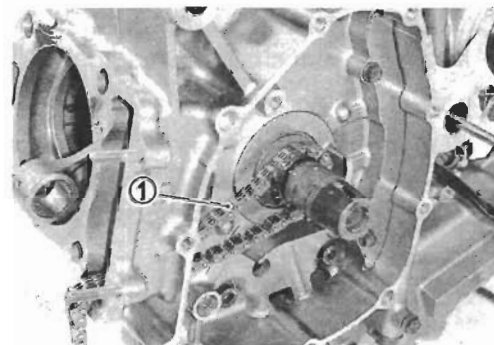



**GENERATOR ROTOR**

- Install the starter driven gear ①.
- Apply engine oil to the bushing of the starter driven gear.

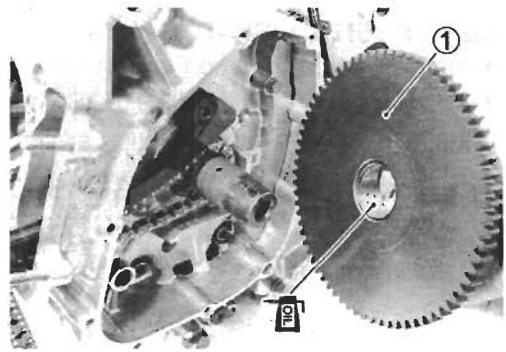

- Degrease the tapered portions (A) of the generator rotor assembly and the crankshaft. Use nonflammable cleaning solvent to wipe off oily or greasy matter and make these surfaces completely dry.
- Fit the key (2) in the key slot on the crankshaft completely.
- Install the generator rotor assembly onto the crankshaft.

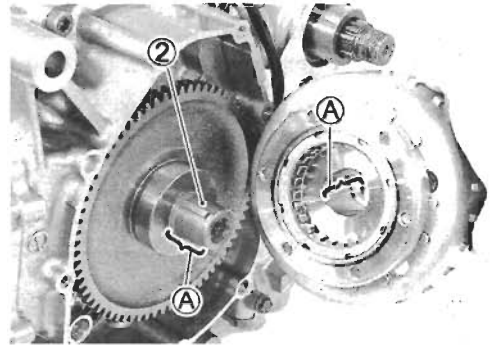

- While holding the generator rotor with the special tool, tighten its bolt to the specified torque.

**TOOL** 09930-44530: Rotor holder

**TOOL** Generator rotor bolt: 120 N·m (12.0 kgf·m, 87 lb-ft)

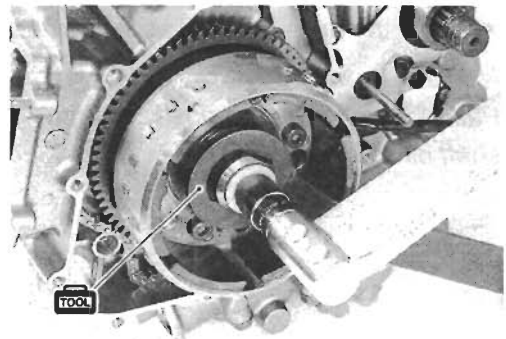
**CAM CHAIN DRIVE SPROCKET**

- Install the cam chain drive sprocket ① onto the crankshaft.

**NOTE:**

- \* Align the punched mark (A) on the cam chain drive sprocket with the punched mark (B) on the crankshaft.
- \* Apply MOLYBDENUM OIL SOLUTION to the cam chain drive sprocket.

**TOOL** MOLYBDENUM OIL SOLUTION

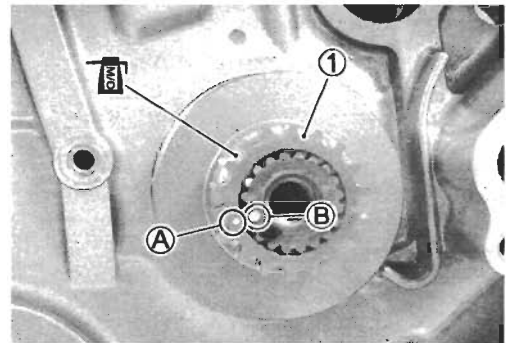

**REAR CAM CHAIN**

- Install the rear cam chain ①.

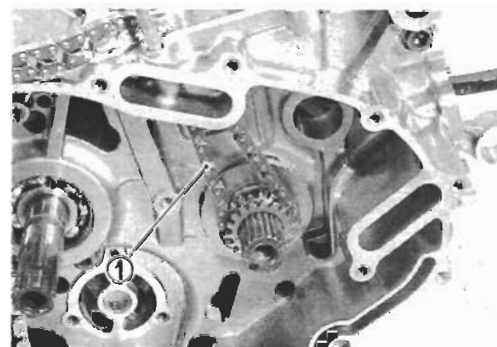

- Install the cam chain tensioner ②, washer ③ and cam chain tensioner bolt ④.
- Tighten the cam chain tensioner bolt ④ to the specified torque.

**🔧 Cam chain tensioner bolt: 10 N·m (1.0 kgf-m, 7.0 lb-ft)**

**NOTE:**

*The front and rear cam chain tensioners are the same.*

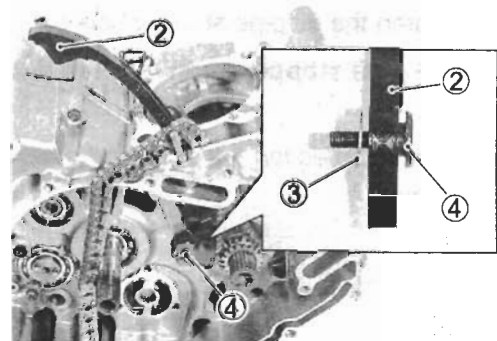
**PRIMARY DRIVE GEAR**

- Install the primary drive gear ① and water pump drive gear ②.

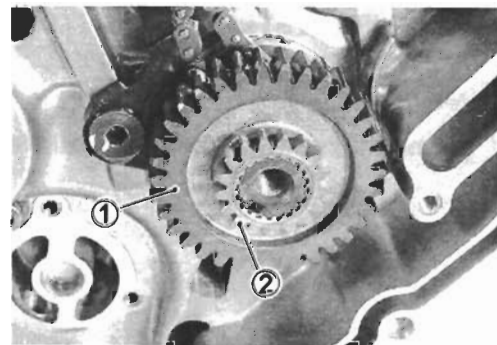

- Hold the generator rotor (crankshaft) with the special tool.

**🔧 09930-44530: Rotor holder**

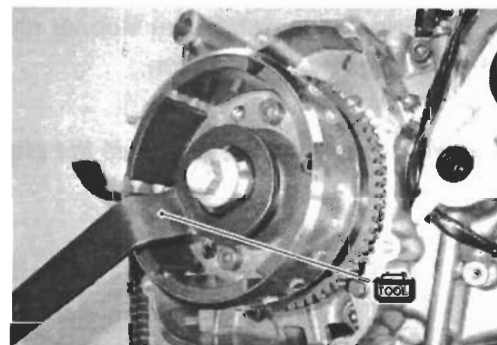

- Tighten the primary drive gear bolt to the specified torque.

**🔧 Primary drive gear bolt: 70 N·m (7.0 kgf-m, 50.5 lb-ft)**

**NOTE:**

*This bolt has left-hand thread.*

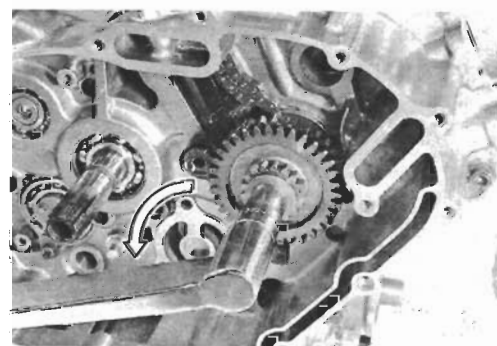

**OIL PIPE**

- Install the oil pipe ①.

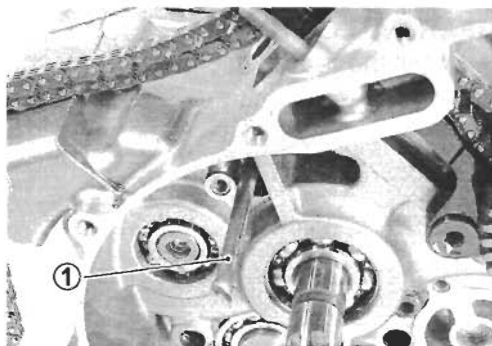

- Tighten the oil pipe stopper screw ② to the specified torque.

**Oil pipe stopper screw: 8 N·m (0.8 kgf-m, 6.0 lb-ft)**

**NOTE:**

Align the projection **A** of the oil pipe with the groove **B** of its stopper.

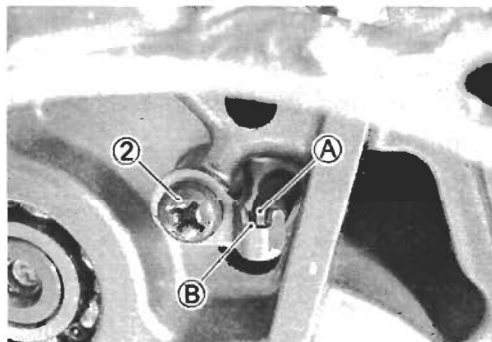
**GEARSHIFT SYSTEM**

- Install the gearshift cam stopper ①, its bolt ②, washer ③ and return spring ④.

**Gearshift cam stopper bolt: 10 N·m (1.0 kgf-m, 7.0 lb-ft)**

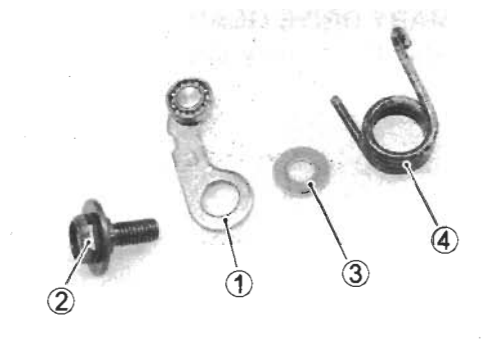

- Confirm the gearshift cam stopper movement.
- Check the neutral position.

**NOTE:**

Hook the return spring end ⑤ to the stopper.

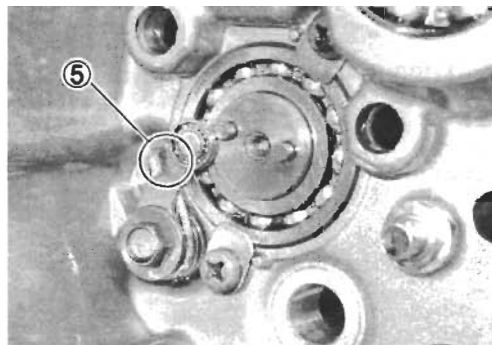

- Install the gearshift cam stopper plate ⑥ with the gearshift cam pins **A** inserted into the gearshift cam stopper plate holes **B**.

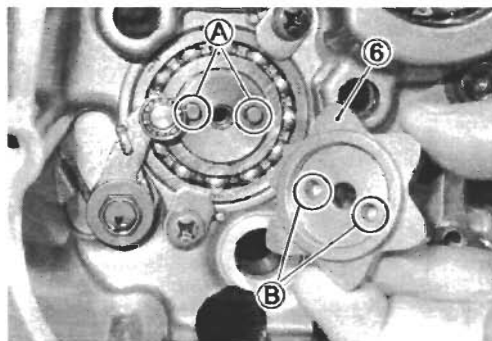

- Apply a small quantity of THREAD LOCK to the gearshift cam stopper plate bolt and tighten it to the specified torque.

 **1342 99000-32050: THREAD LOCK "1342"**

 **Gearshift cam stopper plate bolt: 13 N·m  
(1.3 kgf-m, 9.5 lb-ft)**

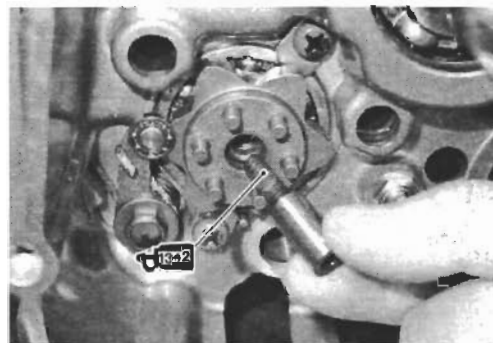

- Install the gearshift shaft/gearshift arm ⑦ with the washer ⑧ as shown.

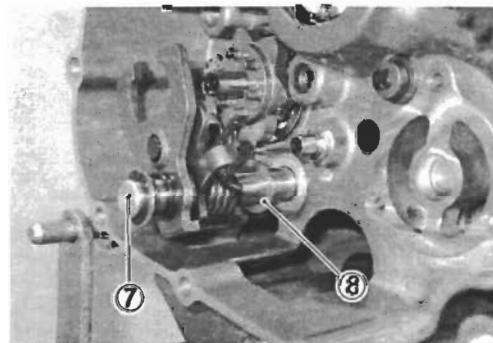

- Locate the gearshift arm stopper ⑨ between return spring ends ③.

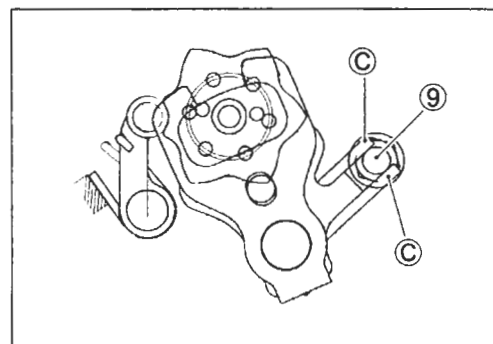

- Install the washer ⑩ and snap ring ⑪.

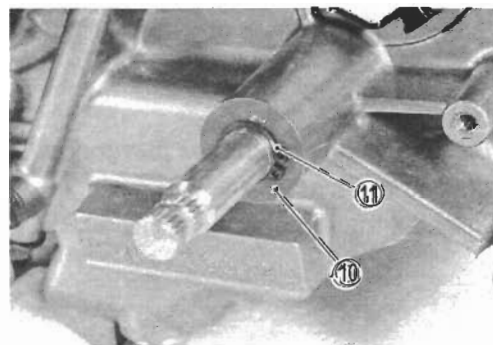

#### OIL PUMP

- Install the oil pump with the three screws.

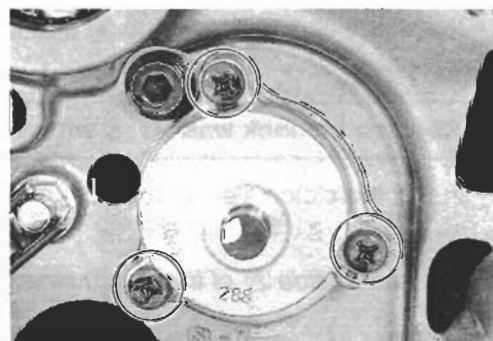

- Install the washer ① and pin ②.

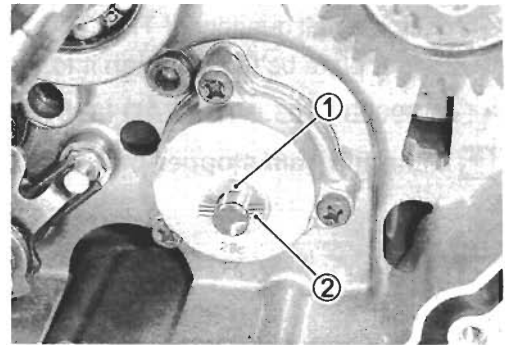

- Install the oil pump driven gear ③.
- Install the snap ring ④.

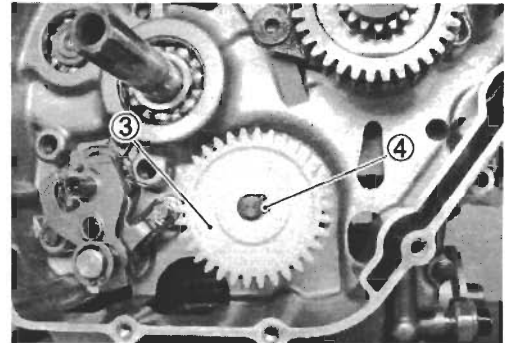

**CLUTCH**

- Install the spacer ① and apply ENGINE OIL to it.

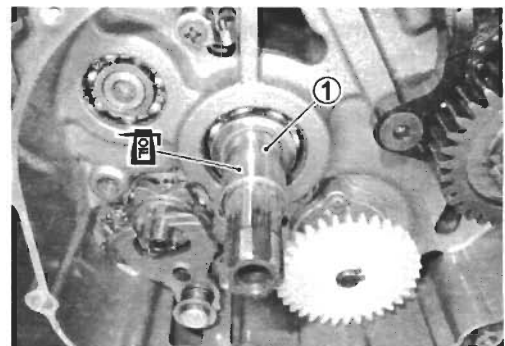

- Install the primary driven gear assembly ② onto the counter-shaft.

**NOTE:**

*Be sure to engage the oil pump drive and driven gears, primary drive and driven gears.*

- Install the thrust washer ③.

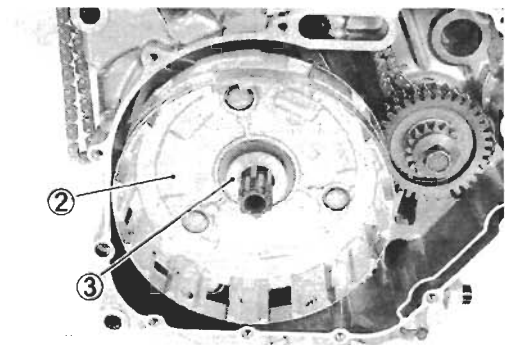

- Install the clutch sleeve hub ④ and lock washer ⑤.

**CAUTION**

**Replace the lock washer ⑤ with a new one.**

- Install the clutch sleeve hub nut ⑥.

**NOTE:**

*The chamfer side (A) of the clutch sleeve hub nut faces outward.*

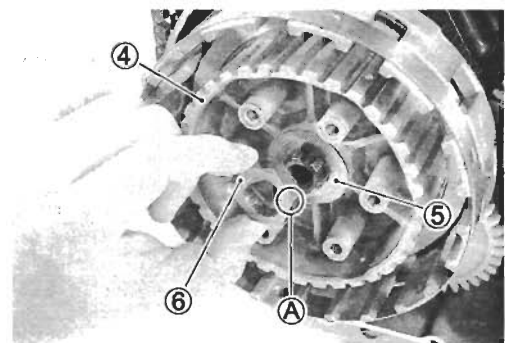

- Hold the clutch sleeve hub with the special tool.

**TOOL** 09920-53740: Clutch sleeve hub holder

- Tighten the clutch sleeve hub nut to the specified torque.

**TOOL** Clutch sleeve hub nut: 50 N·m (5.0 kgf·m, 36.0 lb-ft)

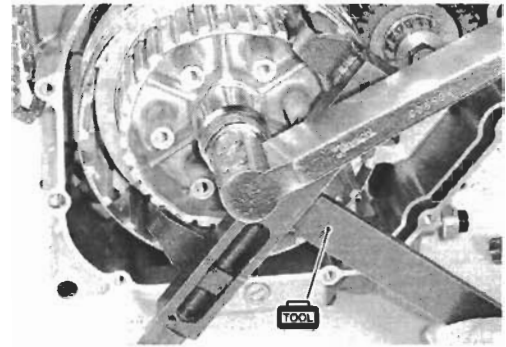

- Bend the lock washer to lock the nut securely.

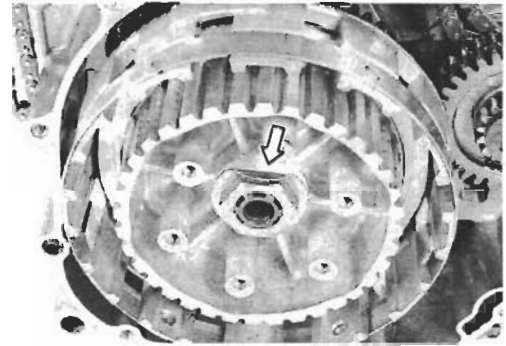

- Install the spring washer seat ⑦ and spring washer ⑧ onto the clutch sleeve hub correctly.

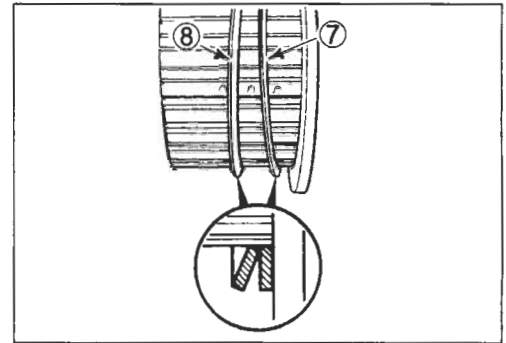

- Insert the clutch drive plates ⑨, ⑩ and driven plates ⑪ one by one into the clutch sleeve hub in the prescribed order, No.2 drive plate ⑨ being inserted first.

**NOTE:**

Apply the *ENGINE OIL* to the clutch driven and drive plates before installing them.

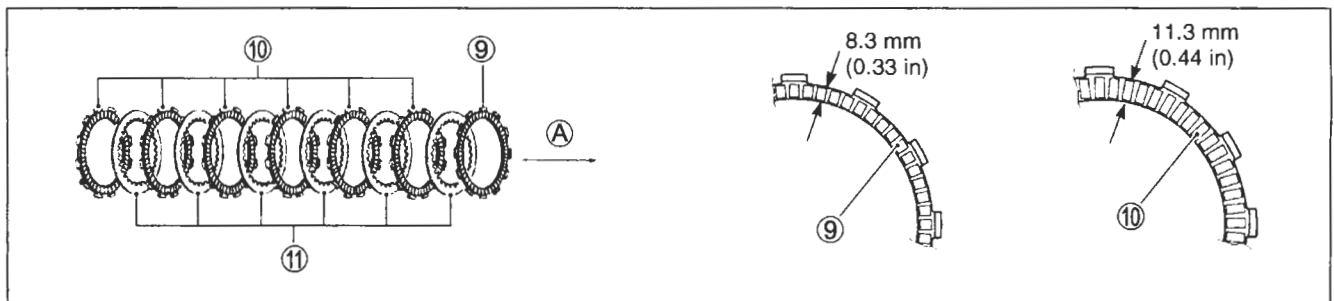
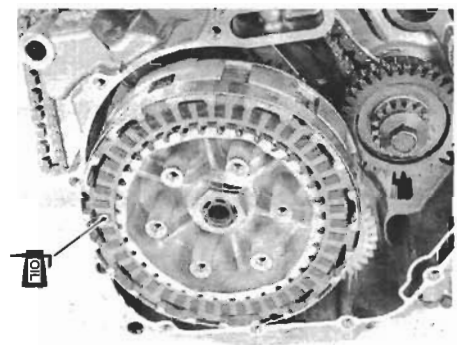

⑨ No.2 Drive plate    ⑩ No.1 Drive plate    Ⓐ Direction of inside.

- Install the clutch push rod ⑫ into the countershaft.

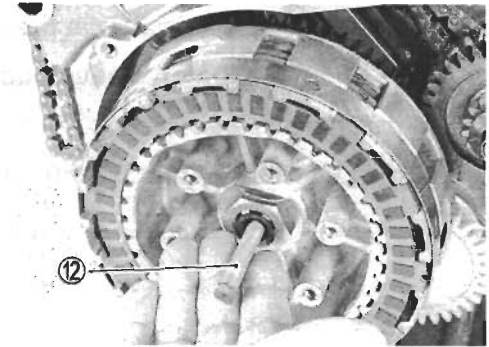

- Install the clutch push piece ⑬, the bearing ⑭ and thrust washer ⑮ to the countershaft.

**NOTE:**

*Thrust washer ⑮ is located between the pressure plate and bearing ⑭.*

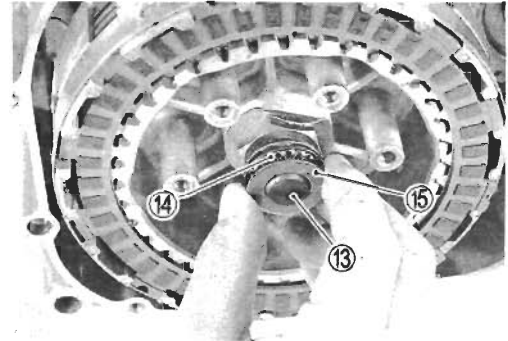

- Hold the generator rotor (crankshaft) with the special tool.

**TOOL** 09930-44530: Rotor holder

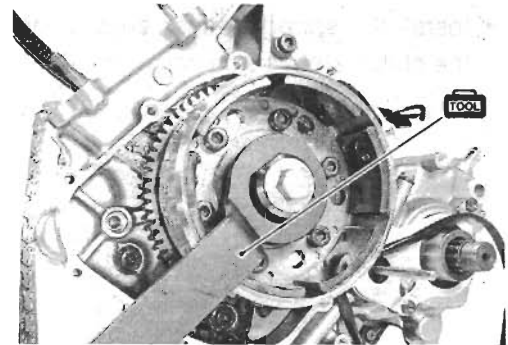

- Install the clutch pressure plate.
- Tighten the clutch spring set bolts to the specified torque.

**Clutch spring set bolt: 10 N·m (1.0 kgf-m, 7.0 lb-ft)**

**NOTE:**

*Tighten the clutch spring set bolts diagonally.*

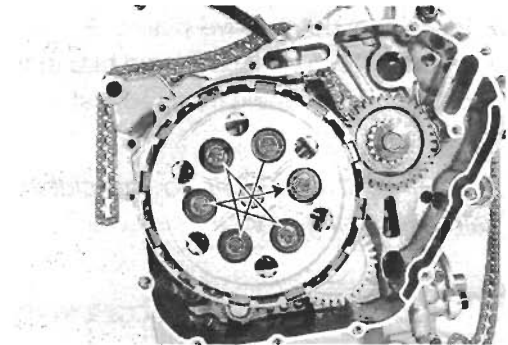

**CLUTCH COVER**

- Install the gasket ① and dowel pins ②.

**CAUTION**

**Use the new gasket to prevent oil leakage.**

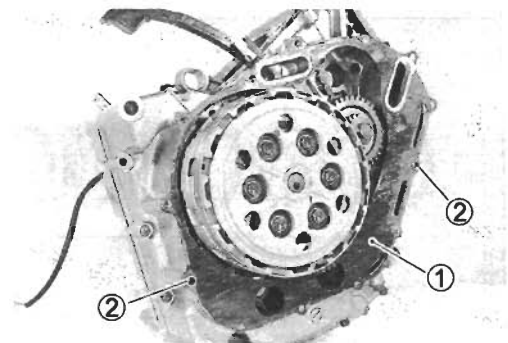

- Install the clutch cover.

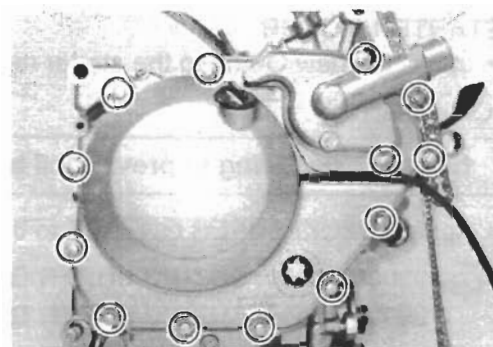

### GENERATOR COVER

- Apply MOLYBDENUM OIL SOLUTION to both ends of the shaft ①.

#### MOLYBDENUM OIL SOLUTION

- Install the starter idle gear ② and shaft ①.

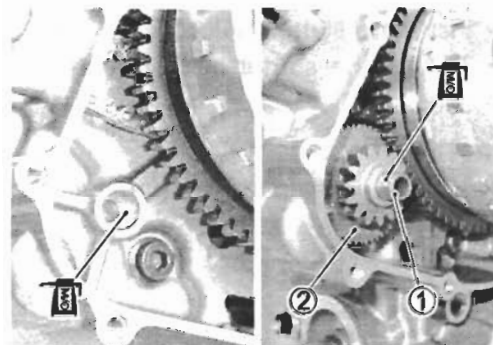

- Install the dowel pins ③ and gasket ④.

#### CAUTION

Use the new gasket to prevent oil leakage.

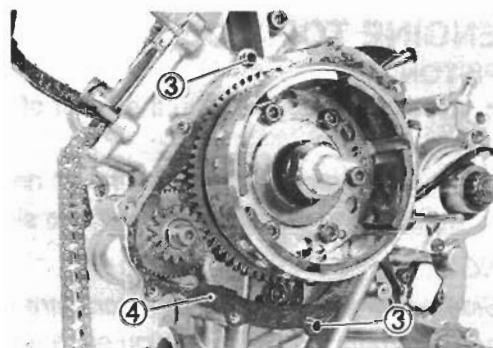

- Install the generator cover.

 Generator cover bolt: 10 N·m (1.0 kgf-m, 7.0 lb-ft)

#### NOTE:

Fit the gasket washers to the generator cover bolts (A) correctly as shown.

#### CAUTION

Use the new gasket washers to prevent oil leakage.

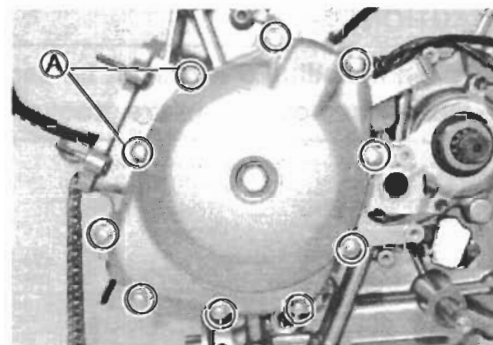

### OIL FILTER

- Install the oil filter with the special tool. (☞ 2-13)

 09915-40610: Oil filter wrench

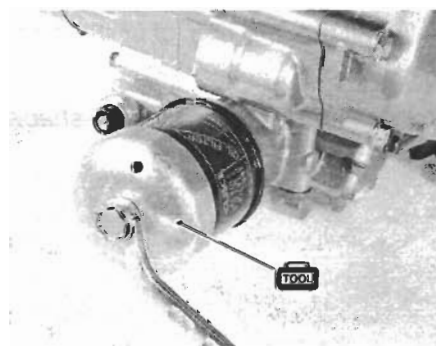



### STARTER MOTOR

- Install the new O-ring to the starter motor.

**CAUTION**

Use the new O-ring to prevent oil leakage.

- Apply SUZUKI SUPER GREASE to the O-ring.

 **99000-25030: SUZUKI SUPER GREASE "A" (USA)**  
**99000-25010: SUZUKI SUPER GREASE "A" (Others)**

- Install the starter motor ①.
- Tighten the starter motor mounting bolts with the clamp ② securely.

**NOTE:**

First tighten the starter motor mounting bolt (A).

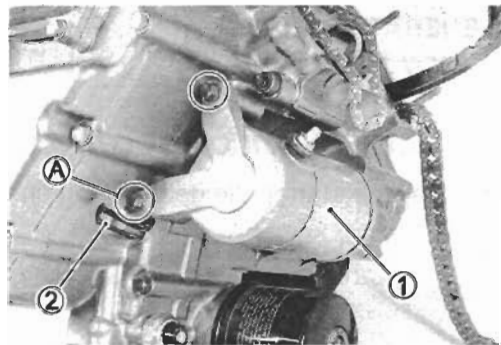
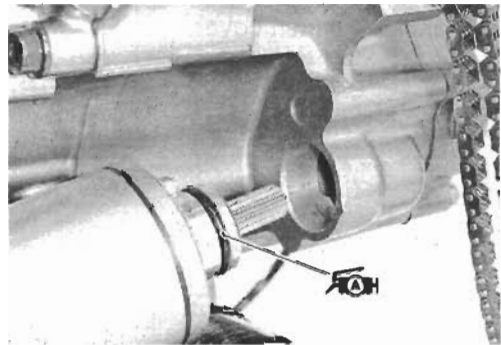

### ENGINE TOP SIDE

#### PISTON

- Install the piston rings in the order of oil ring, 2nd ring and 1st ring.
- The first member to go into the oil ring groove is a spacer ①. After placing the spacer, fit the two side rails ②.

**NOTE:**

Side designations, top and bottom, are not applied to the spacer and side rails: you can position each either way.

**CAUTION**

When installing the spacer, be careful not to allow its two ends to overlap in the groove.

- Ⓐ INCORRECT
- Ⓑ CORRECT

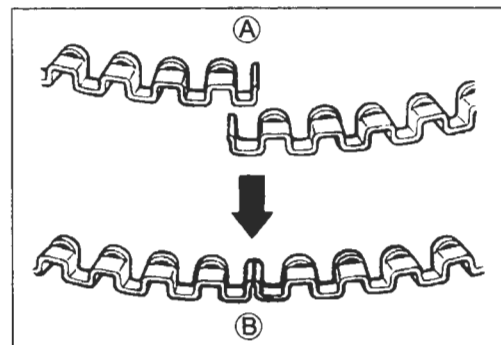
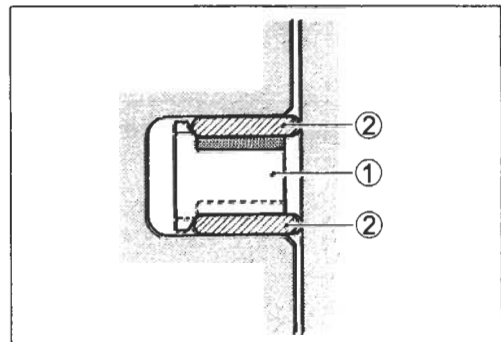

- Install the 2nd ring ③ and 1st ring ④.

**NOTE:**

1st ring and 2nd ring differ in shape.

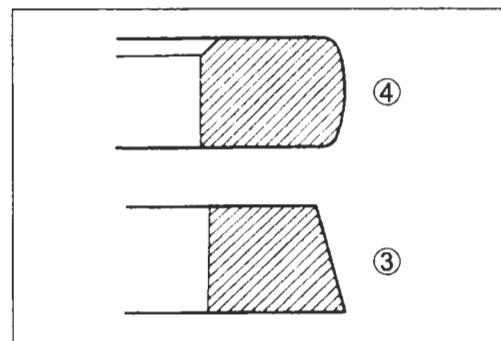

- 1st ring ⑤ and 2nd ring ⑥ have letters "T" marked on the side. Be sure to bring the marked side to the top when fitting them to the piston.

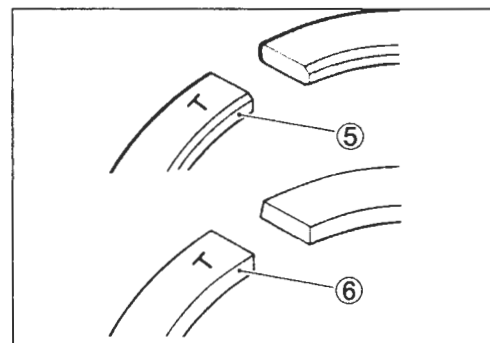

- Position the gaps of the three rings as shown. Before inserting each piston into the cylinder, check that the gaps are so located.

- Ⓐ 2nd ring and Lower side rail
- Ⓑ Upper side rail
- Ⓒ 1st ring and spacer

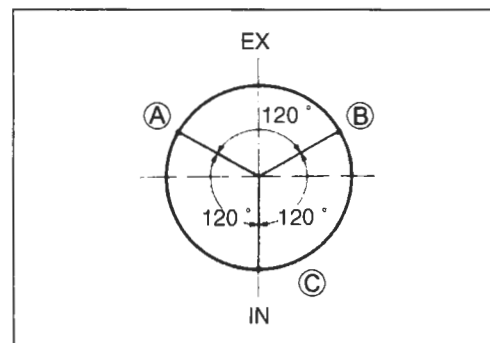

- Apply a small quantity of MOLYBDENUM OIL SOLUTION onto each piston pin.

#### **MOLYBDENUM OIL SOLUTION**

##### **NOTE:**

When installing the pistons, front and rear, the indents ④ on the piston heads must be located to each exhaust side.

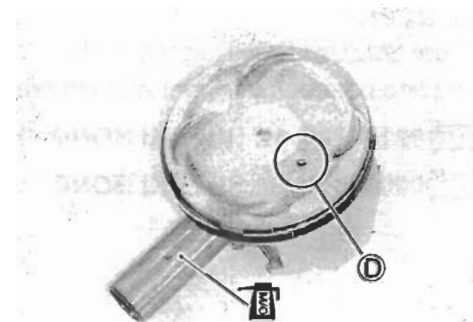

- Place a clean rag over the cylinder base so as not to drop the piston pin circlips into the crankcase.
- Install the pistons ⑦, front and rear.
- Install the piston pin circlips ⑧.

#### **CAUTION**

Use new piston pin circlips to prevent circlip failure which will occur with a bend one.

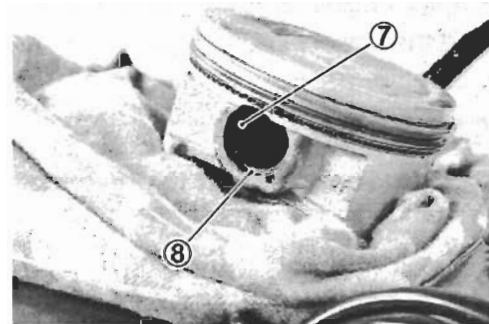

##### **NOTE:**

End gap of the circlip should not be aligned with the cutaway in the piston pin bore.

#### **CAUTION**

When turning the crankshaft, pull the cam chains upward, or the chains will be caught between the crankcase and the cam drive sprocket.

**OIL JET**

- Apply SUZUKI SUPER GREASE to the new O-rings.
- 🔧 **99000-25030: SUZUKI SUPER GREASE "A" (USA)**  
**99000-25010: SUZUKI SUPER GREASE "A" (Others)**
- Apply engine oil to the oil jet holes on the crankcase.

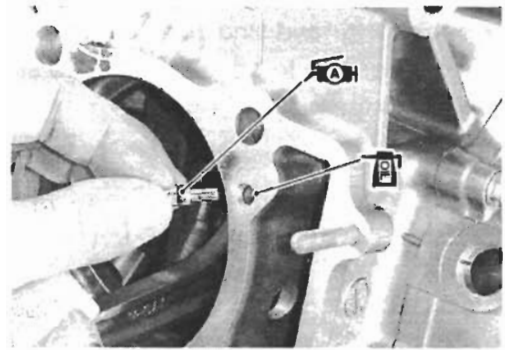

- Install each of the oil jet (#14) to the left and right crankcase, as shown in the illustration.

**CAUTION**

Use the new O-rings to prevent oil leakage.

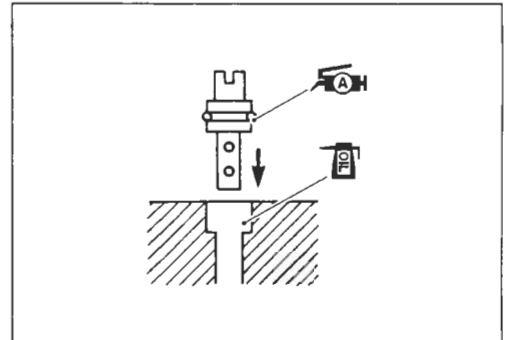

**CYLINDER**

- Coat SUZUKI BOND lightly to the mating surfaces at the parting line between the right and left crankcases as shown.
- 🔧 **1207B 99104-31140: SUZUKI BOND "1207B" (USA)**
- 🔧 **1215 99000-31110: SUZUKI BOND "1215" (Others)**

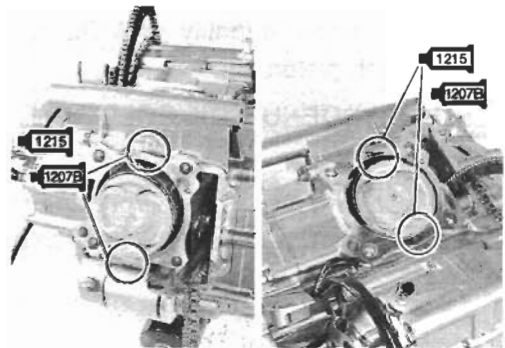

- Apply engine oil to the sliding surface of the pistons.
- Fit the dowel pins ①, ② and new gaskets ③, ④ to the crankcase.

**CAUTION**

Use the new gaskets to prevent oil leakage.

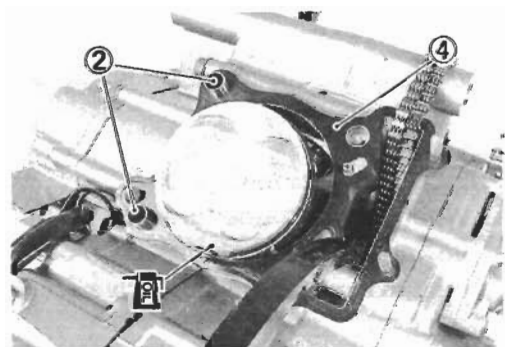
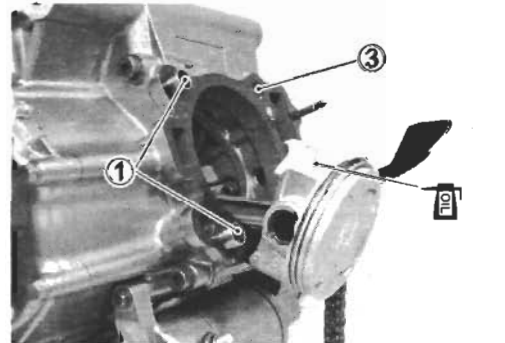

- Apply engine oil to the sliding surface of the cylinders.

**NOTE:**

The front and rear cylinders can be distinguished by the embossed-letters **A**.

"FRONT" : Front cylinder

"REAR" : Rear cylinder

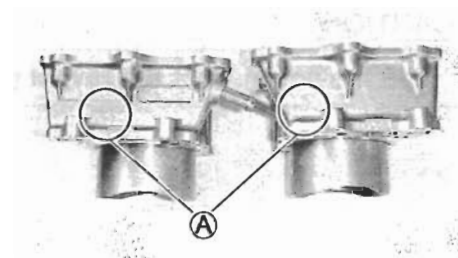

- Hold the piston rings in proper position, and insert each of the piston into the respective cylinders.

**NOTE:**

When installing the cylinders, keep the cam chains taut. The cam chain must not be caught between cam drive sprocket and crankcase when turning the crankshaft.

- Tighten the cylinder nuts (M6) temporarily.

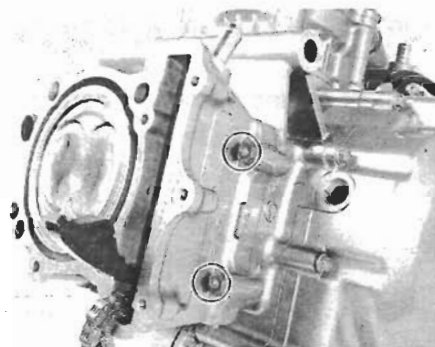
**CYLINDER HEAD**

- The cylinder heads can be distinguished by the embossed-letters **A**.

"F" : Front cylinder head

"R" : Rear cylinder head

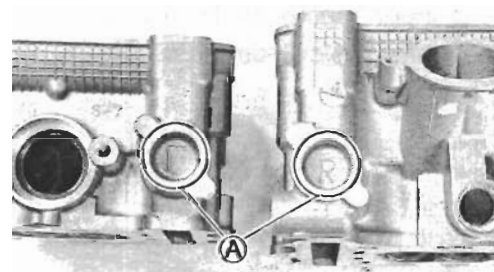

- Pull the cam chain out of the cylinder and install the cam chain guide **1**.

**CAUTION**

There is the guide holder for the bottom end of the cam chain guide **1** cast in the crankcase. Be sure that the cam chain guide **1** is inserted properly.

**NOTE:**

The front and rear cam chain guides are the same.

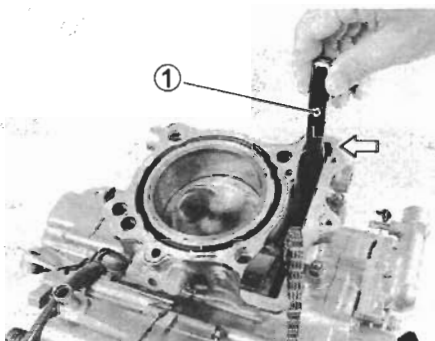

- Fit the dowel pins ② and new cylinder head gasket ③ to the cylinder.

**CAUTION**

Use the new gasket to prevent gas leakage.

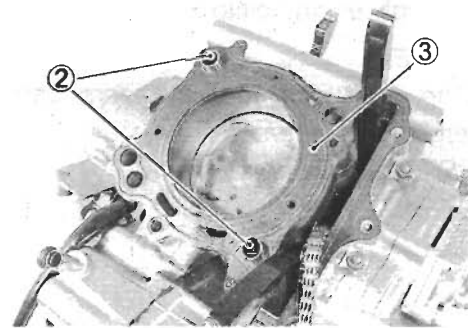

- Install the washers ④ to the cylinder head bolts (M10) ⑤ as shown.
- Apply engine oil to the washers and thread portion of the bolts before installing the cylinder head bolts.

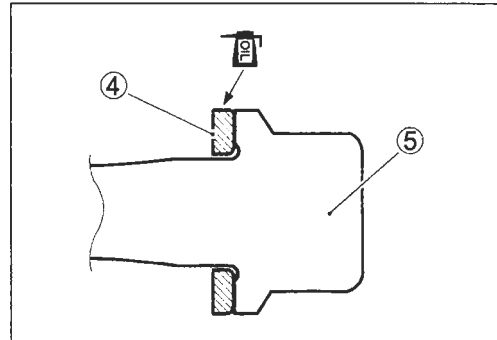

- Place the rear cylinder head on the cylinder.

**NOTE:**

When installing the cylinder head, keep the cam chain taut.

- Tighten the cylinder head bolts (M10) to the specified two-step torque with a torque wrench sequentially and diagonally.

**🔩 Cylinder head bolt (M10):**

**Initial 25 N-m (2.5 kgf-m, 18.0 lb-ft)**

**Final 42 N-m (4.2 kgf-m, 30.5 lb-ft)**

- After firmly tightening the cylinder head bolts (M10), install the cylinder head bolts (M6) ⑥, ⑦.
- Tighten the cylinder head bolts ⑥, ⑦, and cylinder nuts ⑧.

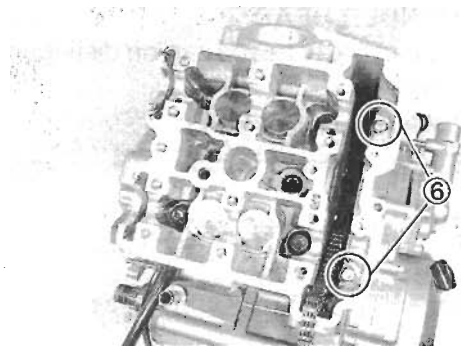
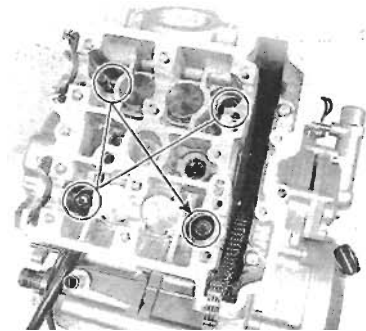

- Install the front cylinder head in same manner as the rear cylinder head installation.

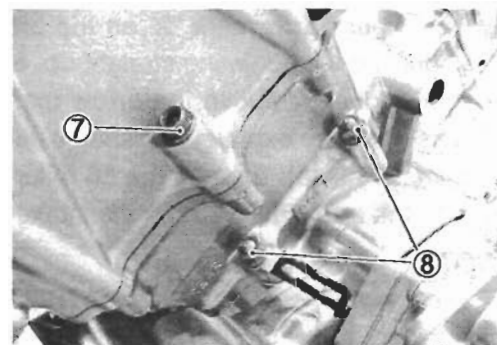

### CAM SHAFT

- The cam shafts are identified by the embossed letters.
  - INF : No.1 (Front) intake camshaft ①
  - EXF : No.1 (Front) exhaust camshaft ②
  - INR : No.2 (Rear) intake camshaft ③
  - EXR : No.2 (Rear) exhaust camshaft ④
- Before installing the camshafts to the cylinder head, apply MOLYBDENUM OIL SOLUTION to their journals.

### MOLYBDENUM OIL SOLUTION

#### No.1 (Front) Camshafts

- Turn the crankshaft counterclockwise with the box wrench and align “|F” line (A) on the generator rotor with the index mark (B) of the valve timing inspection hole while keeping the cam chains pulled upward.

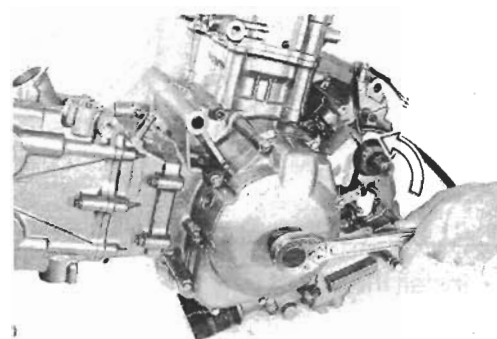
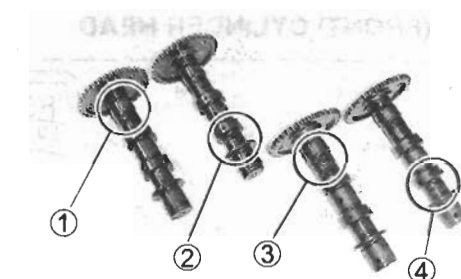

### CAUTION

- \* Pull the cam chains upward, or the chain will be caught between crankcase and cam drive sprocket.
- \* To adjust the camshaft timing correctly, be sure to align “|F” line (A) with the index mark (B) and hold this position when installing the camshafts.

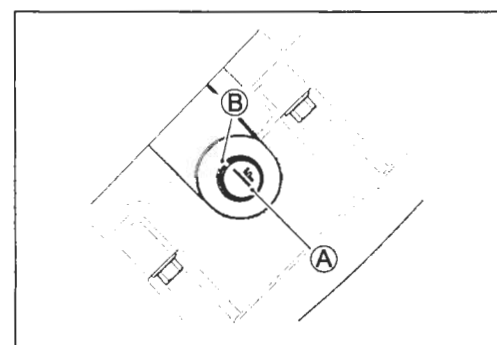

- Pull the cam chain lightly.
- The No.1 exhaust camshaft sprocket has an arrow mark “1F” (C). Install the exhaust camshaft so that the arrow (C) is aligned with the mating surface of the cylinder head. (P3-100)
- Engage the cam chain with the exhaust camshaft sprocket.

#### NOTE:

Before installing the camshaft, check that the tappets are installed correctly.

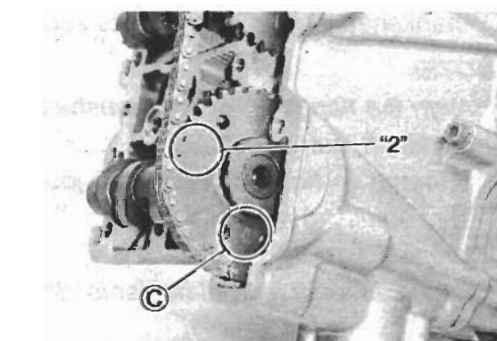

- The other arrow mark "2" on the exhaust camshaft sprocket should now be pointing straight up. Starting from the roller pin that is directly above the arrow mark "2" count out 16 roller pins (from the exhaust camshaft side going towards the intake camshaft side). Engage the 16 roller pin ① on the cam chain with the arrow mark "3" on the intake sprocket. (☞ 3-100)

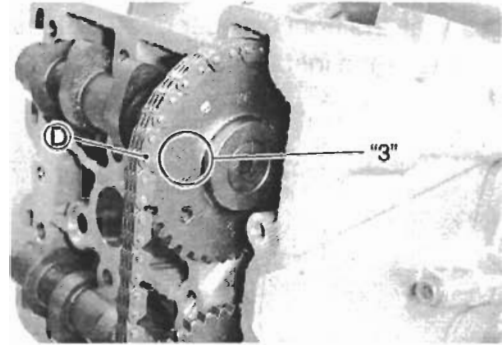

**NOTE:**

The cam chain should now be on all three sprockets. Be careful not to move the crankshaft until the camshaft journal holders and cam chain tension adjuster is secured.

**No.1 (FRONT) CYLINDER HEAD**

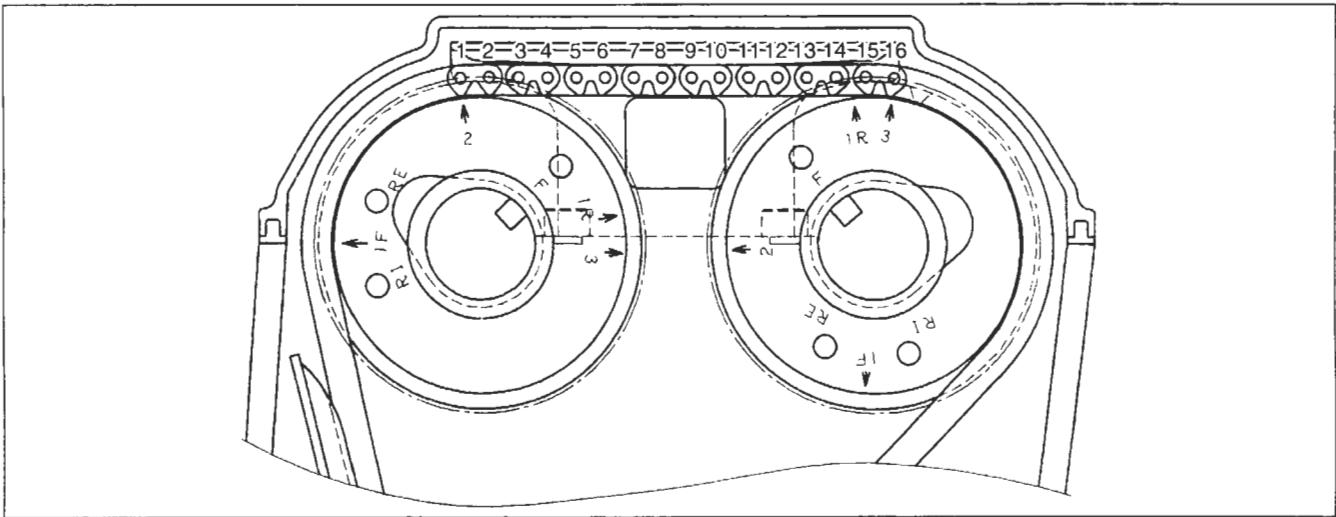

- Install the dowel pins ①.

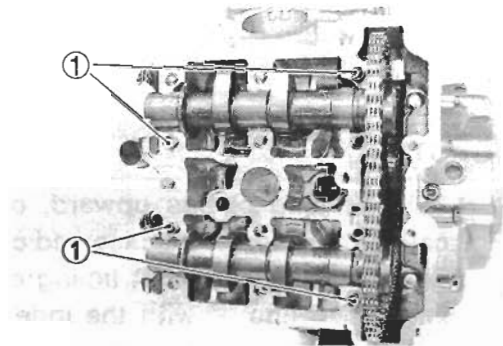

- Apply engine oil to the camshaft journal holders.
- Install the camshaft journal holders, intake and exhaust.
- Fasten the camshaft journal holders evenly by tightening the crankshaft journal holder bolts sequentially and diagonally.

**NOTE:**

- \* Align the flange ⑤ of the camshafts with the groove ⑥ of the camshaft journal holders.
- \* Damage to head or camshaft journal holder thrust surfaces may result if the camshaft journal holders are not drawn down evenly.
- \* Each camshaft journal holder is identified with a cast-on letters ⑦.

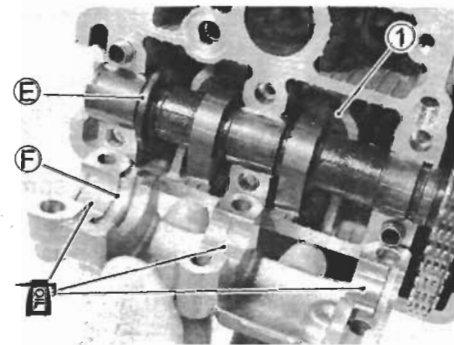

- Tighten the camshaft journal holder bolts to the specified torque.

**🔧 Camshaft journal holder bolt: 10 N·m (1.0 kgf-m, 7.0 lb-ft)**

**CAUTION**

The camshaft journal holder bolts are made of a special material and much superior in strength, compared with other types of high strength bolts. Take special care not to use other types of bolts instead of these special bolts. To identify these bolts, each of them has a figure "9" on its head.

- Recheck the front camshaft positions, intake and exhaust.

**Cam chain tension adjuster**

- With the spring holder bolt and spring removed from the cam chain tension adjuster, release locking of the ratchet mechanism ① and push the push rod ② all the way in.

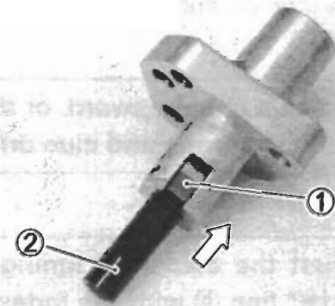

- Install the gasket and oil jet.
- Install the cam chain tension adjuster ③ with "UP" mark faced to the top of cylinder head.
- Tighten the cam chain tension adjuster mounting bolts to the specified torque.

**CAUTION**

Use the new gasket to prevent oil leakage.

**🔧 Cam chain tension adjuster mounting bolt:  
10 N·m (1.0 kgf-m 7.0 lb-ft)**

- Install the spring ④, gasket ⑤ and spring holder bolt ⑥.

**CAUTION**

Use the new gasket to prevent oil leakage.

- Tighten the cam chain tension adjuster cap bolt to the specified torque.

**🔧 Cam chain tension adjuster cap bolt:  
23 N·m (2.3 kgf-m, 16.5 lb-ft)**

**CAUTION**

After installing the cam chain tension adjuster, check to be sure that the adjuster work properly by checking the slack of cam chain.

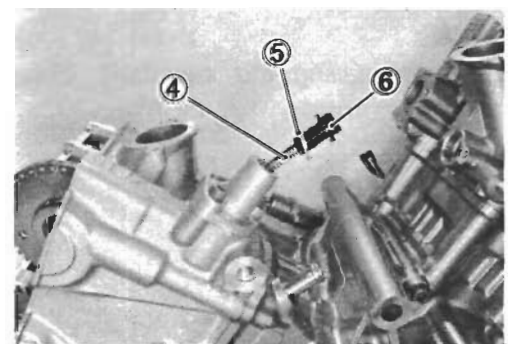
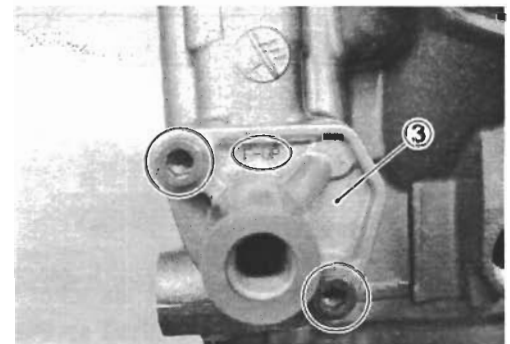
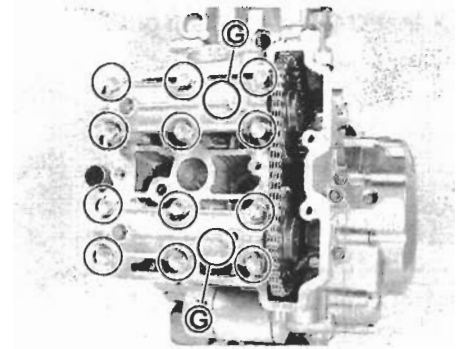



- Install the cam chain guide ⑦.

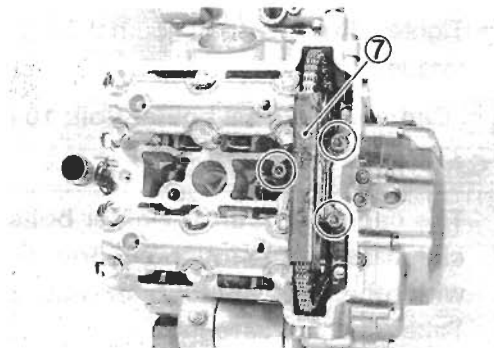

### No.2 (Rear) Camshafts

- From the position where the front camshafts have now been installed, rotate the generator rotor 360 degrees (1 turn) counterclockwise and align the “|F” line ① on the generator rotor with the index mark ② of the valve timing inspection hole.

#### CAUTION

Pull the cam chain upward, or the chain will be caught between crankcase and cam drive sprocket.

#### CAUTION

To adjust the camshaft timing correctly, be sure to align “|F” line ① with the index mark ② and hold this position when installing the camshafts.

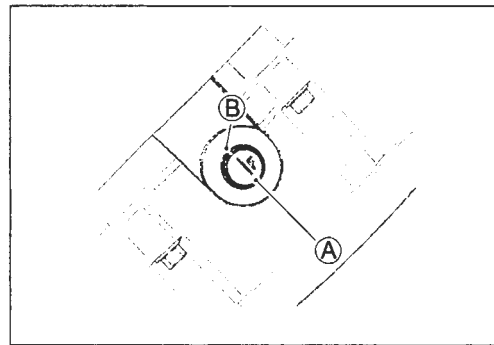
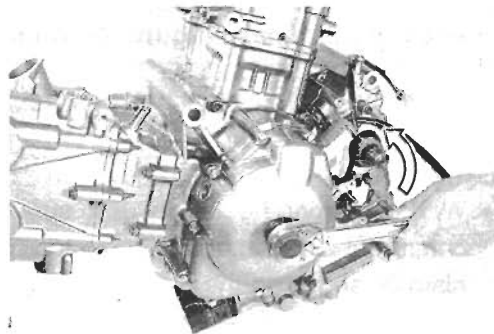

- Pull the cam chain lightly.
- The No.2 intake camshaft sprocket has an arrow mark “1R” ③. Install the intake camshaft so that the arrow ③ is aligned with the mating surface of the cylinder head. (☞ 3-103)
- Engage the cam chain with the intake camshaft sprocket.

#### NOTE:

Before installing the camshaft, check that the tappets are installed correctly.

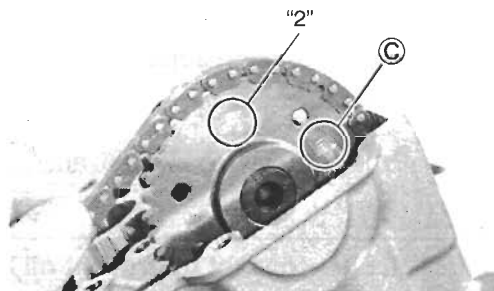

- The other arrow mark "2" on the intake camshaft sprocket should now be pointing straight up. Starting from the roller pin that is directly above the arrow mark "2" count out 16 roller pins (from the intake camshaft side going towards the exhaust camshaft side). Engage the 16th roller pin ① on the cam chain with the arrow mark "3" on the exhaust sprocket.

( 3-103)

**NOTE:**

The cam chain should now be on all three sprockets. Be careful not to move the crankshaft until the camshaft journal holders and cam chain tension adjuster is secured.

**No.2 (REAR) CYLINDER HEAD**

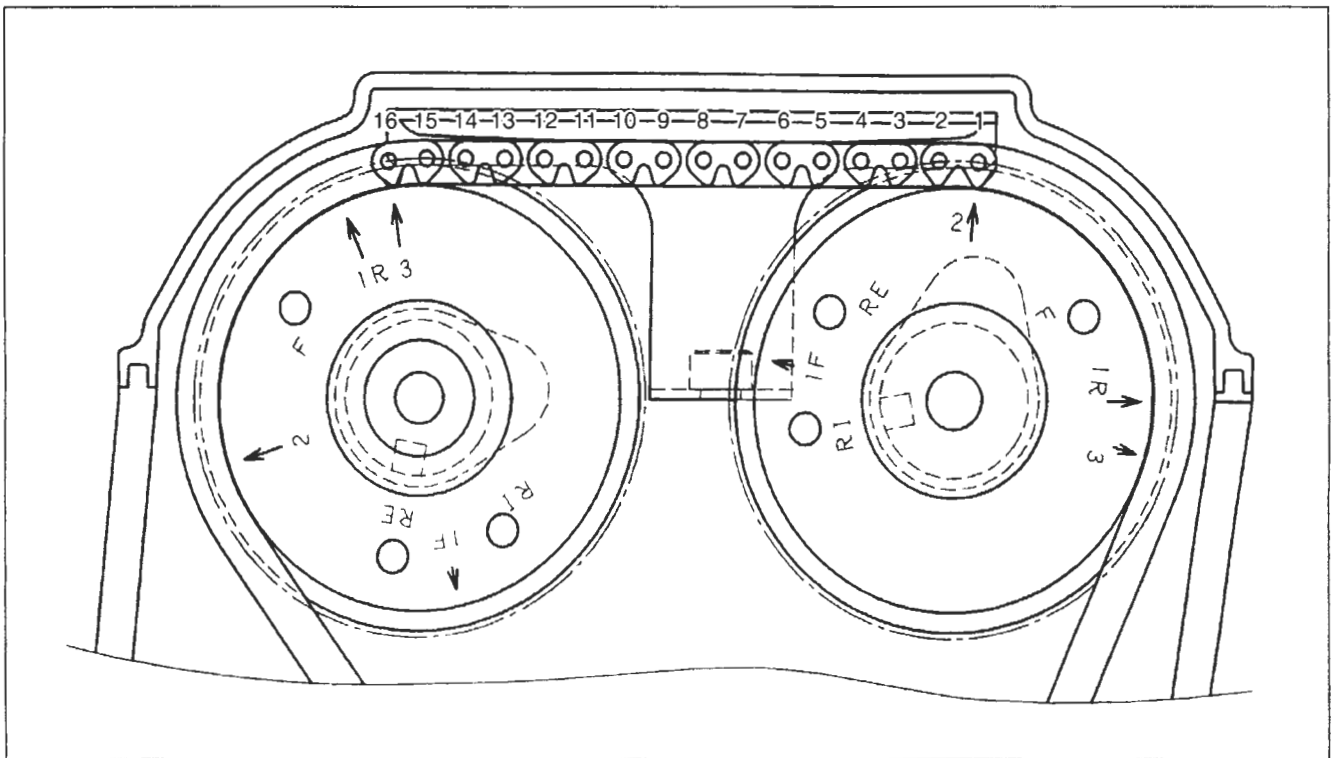

- Install the dowel pins ①.

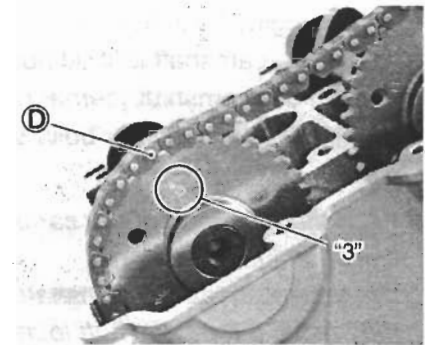
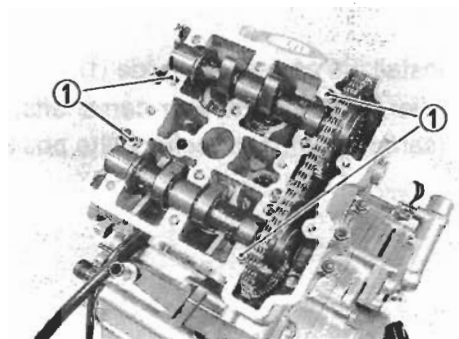

- Apply engine oil to the camshaft journal holders.
- Install the camshaft journal holders, intake and exhaust.
- Fasten the camshaft journal holders evenly by tightening the camshaft journal holder bolts sequentially and diagonally.

**NOTE:**

- \* Align the flange ⑤ of the camshafts with the groove ⑥ of the camshaft journal holders.
- \* Damage to head or camshaft journal holder thrust surfaces may result if the camshaft journal holders are not drawn down evenly.
- \* Each camshaft journal holder is identified with a cast-on letter ⑦.

- Tighten the camshaft journal holder bolts to the specified torque.

**Camshaft journal holder bolt: 10 N·m  
(1.0 kgf-m, 7.0 lb-ft)**

**CAUTION**

The camshaft journal holder bolts are made of a special material and much superior in strength, compared with other types of high strength bolts. Take special care not to use other types of bolts instead of these special bolts. To identify these bolts, each of them has a figure "9" on its head.

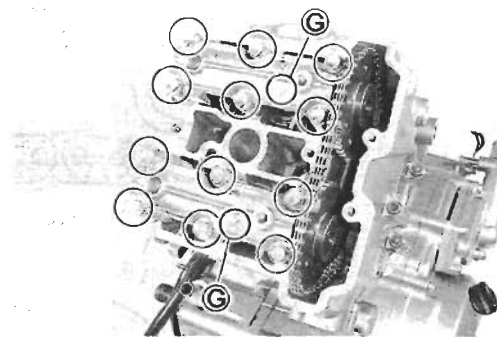
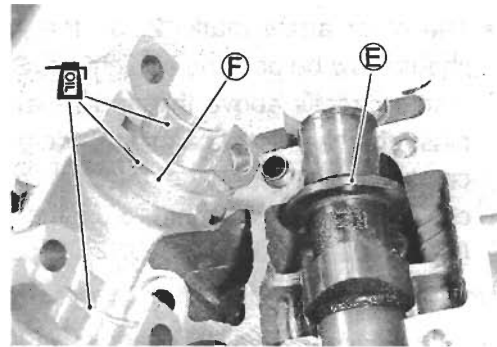

- Recheck the rear camshaft positions, intake and exhaust.

**Cam chain tension adjuster**

- Install the cam chain tension adjuster. (☞ 3-101)
- Install the cam chain guide ①.
- After installing the rear camshafts, rotate the generator rotor (same turns), and recheck the positions of the camshafts.

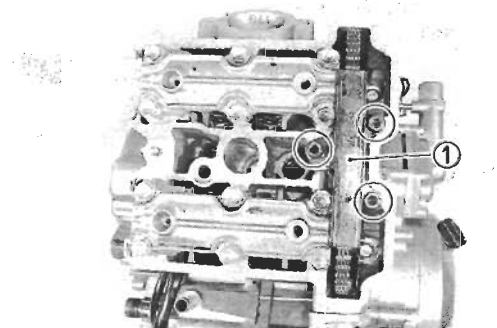

No.1 (Front) cylinde TDC of compression stroke

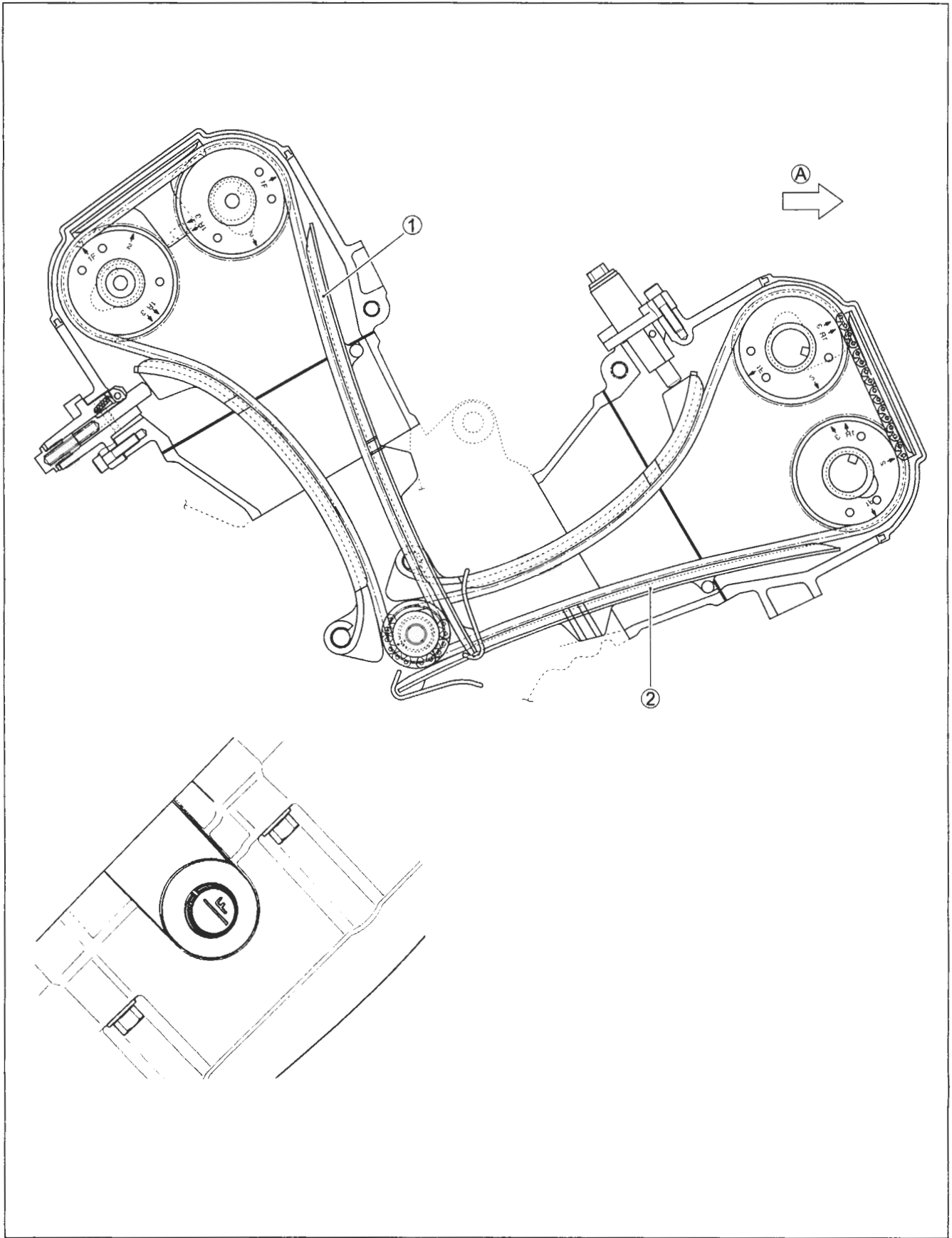

① Cam chain guide    ② Cam chain guide    A Forward

**CYLINDER HEAD COVER**

- Pour engine oil in each oil pocket in the front and rear cylinder heads.

**NOTE:**

Be sure to check the valve clearance. (☞ 2-8)

- Install the dowel pins ① and O-rings ②.

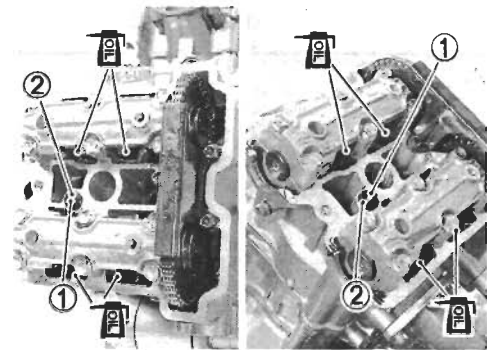

- Install the new gaskets to each cylinder head cover.
- Apply SUZUKI BOND to the cam end caps of the gaskets.

☐ 1207B 99104-31140: SUZUKI BOND “1207B” (USA)

☐ 1215 99000-31110: SUZUKI BOND “1215” (Others)

**CAUTION**

Use the new gaskets to prevent oil leakage.

- The cylinder head covers can be distinguished by the embossed letters A.

“F”: Front cylinder head cover

“R”: Rear cylinder head cover

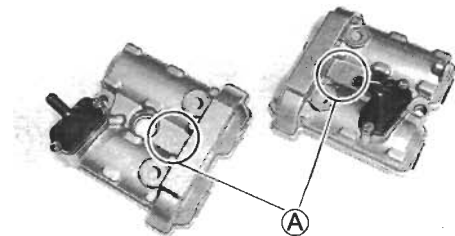
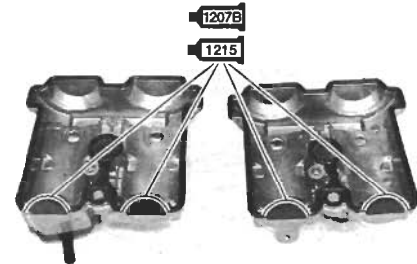

- Install the cylinder head covers on each cylinder head.
- Fit the gaskets ③, ④ to each head cover bolt.

**CAUTION**

Use the new gaskets to prevent oil leakage.

**NOTE:**

The metal side of the gasket ③ must face to the bolt flange.

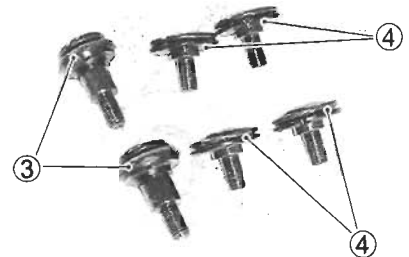

- After applying engine oil to the gaskets tighten the head cover bolts to the specified torque.

☐ Head cover bolt: 14 N·m (1.4 kgf·m, 10.0 lb·ft)

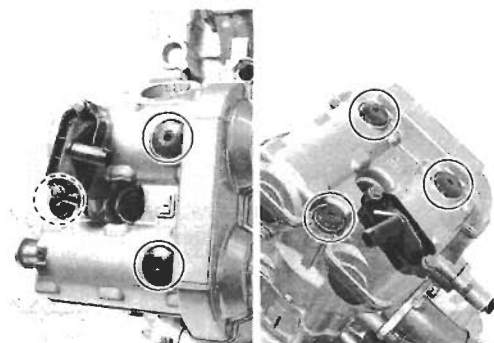

**EXHAUST PIPE**

- Tighten the exhaust pipe bolts ① to the specified torque.

**🔧 Exhaust pipe bolt: 23 N·m (2.3 kgf·m, 16.5 lb·ft)**

**CAUTION**

**Use the new gasket to prevent exhaust gas leakage.**

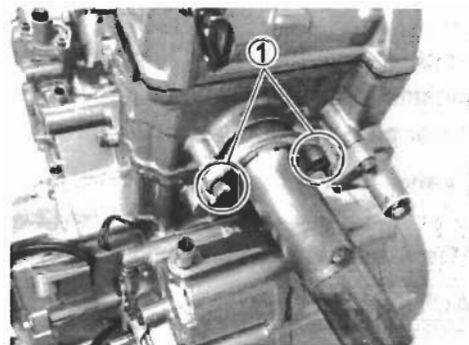
**WATER UNION**

- Install the O-ring to the water union.

**CAUTION**

**Replace the O-ring with a new one.**

- When installing the water union, apply engine coolant to the O-ring.

**🔧 ENGINE COOLANT****INTAKE PIPE**

- Apply SUZUKI SUPER GREASE to the O-ring.

**🔧 99000-25030: SUZUKI SUPER GREASE "A" (USA)**  
**99000-25010: SUZUKI SUPER GREASE "A" (Others)**

**CAUTION**

**Use the new O-ring to prevent air from sucking through the joint.**



- Make sure that the "UP" mark ① faces upward.
- Install the intake pipes.

**NOTE:**

*The intake pipe can be identified by the mark ②.*

*F: Front cylinder head intake pipe*

*R: Rear cylinder head intake pipe*

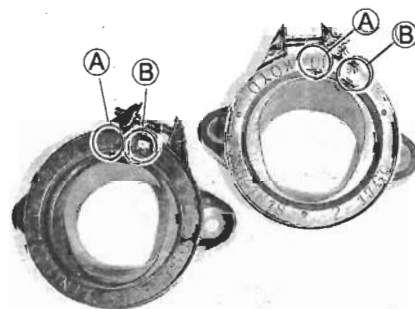

**GENERATOR COVER PLUG**

- Apply engine oil to the O-ring of the generator cover plug.
- Tighten the valve timing inspection plug ① and generator cover plug ② to the specified torque.

🔧 **Valve timing inspection plug: 23 N·m**  
(2.3 kgf-m, 16.3 lb-ft)

**Generator cover plug: 11 N·m (1.1 kgf-m, 8.0 lb-ft)**

**CAUTION**

Use the new O-ring to prevent oil leakage.

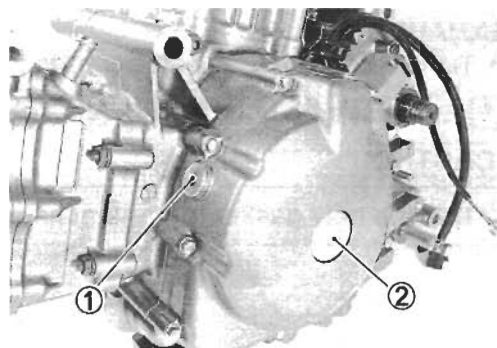
**THERMOSTAT CASE AND WATER HOSE**

- Install the thermostat case ① along with the water hoses ② and tighten the clamp screws securely. (☞ 9-24)

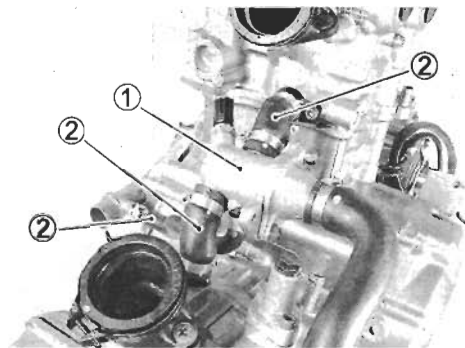
**SPARK PLUG AND HOSES**

- Connect the PAIR hoses ①.
- Connect the crankcase breather hoses ②.
- Install the spark plugs. (☞ 2-8)

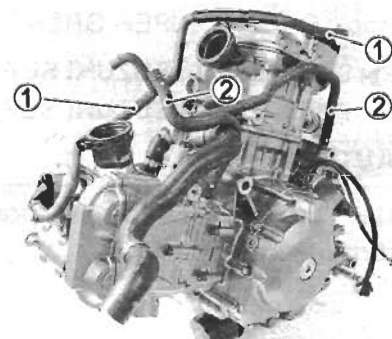

# FI SYSTEM DIAGNOSIS

## CONTENTS

<b>PRECAUTIONS IN SERVICING</b> .....	4- 2
<b>ELECTRICAL PARTS</b> .....	4- 2
<b>FUSE</b> .....	4- 3
<b>ECM/VARIOUS SENSORS</b> .....	4- 3
<b>ELECTRICAL CIRCUIT INSPECTION PROCEDURE</b> .....	4- 5
<b>USING TESTERS</b> .....	4- 8
<b>FI SYSTEM TECHNICAL FEATURES</b> .....	4- 9
<b>INJECTION TIME (INJECTION VOLUME)</b> .....	4- 9
<b>COMPENSATION OF INJECTION TIME (VOLUME)</b> .....	4-10
<b>INJECTION STOP CONTROL</b> .....	4-10
<b>FI SYSTEM PARTS LOCATION</b> .....	4-11
<b>FI SYSTEM WIRING DIAGRAM</b> .....	4-13
<b>SELF-DIAGNOSIS FUNCTION</b> .....	4-14
<b>USER MODE</b> .....	4-14
<b>DEALER MODE</b> .....	4-15
<b>TPS ADJUSTMENT</b> .....	4-16
<b>FAIL-SAFE FUNCTION</b> .....	4-17
<b>FI SYSTEM TROUBLESHOOTING</b> .....	4-18
<b>CUSTOMER COMPLAINT ANALYSIS</b> .....	4-18
<b>SELF-DIAGNOSTIC PROCEDURES</b> .....	4-20
<b>SELF-DIAGNOSIS RESET PROCEDURE</b> .....	4-20
<b>MALFUNCTION CODE AND DEFECTIVE CONDITION</b> .....	4-21
<b>"C12" CKP SENSOR CIRCUIT MALFUNCTION</b> .....	4-23
<b>"C13" IAP SENSOR CIRCUIT MALFUNCTION</b> .....	4-25
<b>"C14" TP SENSOR CIRCUIT MALFUNCTION</b> .....	4-28
<b>"C15" ECT SENSOR CIRCUIT MALFUNCTION</b> .....	4-31
<b>"C21" IAT SENSOR CIRCUIT MALFUNCTION</b> .....	4-33
<b>"C23" TO SENSOR CIRCUIT MALFUNCTION</b> .....	4-35
<b>"C24" or "C25" IGNITION SYSTEM MALFUNCTION</b> .....	4-36
<b>"C28" STV ACTUATOR CIRCUIT MALFUNCTION</b> .....	4-37
<b>"C29" STP SENSOR CIRCUIT MALFUNCTION</b> .....	4-38
<b>"C31" GEAR POSITION (GP) SWITCH CIRCUIT MALFUNCTION</b> .....	4-41
<b>"C32" or "C33" FUEL INJECTOR CIRCUIT MALFUNCTION</b> .....	4-42
<b>"C41" FP RELAY CIRCUIT MALFUNCTION</b> .....	4-44
<b>"C42" IG SWITCH CIRCUIT MALFUNCTION</b> .....	4-44
<b>"C49" PAIR CONTROL SOLENOID VALVE CIRCUIT MALFUNCTION</b> .....	4-45
<b>"C44" HO2 SENSOR (HO2S) CIRCUIT MALFUNCTION (E-02, 19)</b> .....	4-47



<b>SENSORS</b> .....	<b>4-49</b>
<b>CKP SENSOR INSPECTION</b> .....	<b>4-49</b>
<b>CKP SENSOR REMOVAL AND INSTALLATION</b> .....	<b>4-49</b>
<b>IAP SENSOR INSPECTION</b> .....	<b>4-49</b>
<b>IAP SENSOR REMOVAL AND INSTALLATION</b> .....	<b>4-49</b>
<b>TP SENSOR INSPECTION</b> .....	<b>4-49</b>
<b>TP SENSOR REMOVAL AND INSTALLATION</b> .....	<b>4-49</b>
<b>TPS ADJUSTMENT</b> .....	<b>4-49</b>
<b>ECT SENSOR INSPECTION</b> .....	<b>4-49</b>
<b>ECT SENSOR REMOVAL AND INSTALLATION</b> .....	<b>4-49</b>
<b>IAT SENSOR INSPECTION</b> .....	<b>4-50</b>
<b>IAT SENSOR REMOVAL AND INSTALLATION</b> .....	<b>4-50</b>
<b>TO SENSOR INSPECTION</b> .....	<b>4-50</b>
<b>TO SENSOR REMOVAL AND INSTALLATION</b> .....	<b>4-50</b>
<b>STP SENSOR INSPECTION</b> .....	<b>4-50</b>
<b>STP SENSOR REMOVAL AND INSTALLATION</b> .....	<b>4-50</b>
<b>STP SENSOR ADJUSTMENT</b> .....	<b>4-50</b>
<b>HO2 SENSOR INSPECTION (E-02, 19)</b> .....	<b>4-50</b>
<b>HO2 SENSOR REMOVAL AND INSTALLATION</b> .....	<b>4-50</b>

## PRECAUTIONS IN SERVICING

When handling the component parts or servicing the FI system, observe the following points for the safety of the system.

### ELECTRICAL PARTS

#### CONNECTOR/COUPLER

- When connecting a connector, be sure to push it in until a click is felt.
- With a lock type coupler, be sure to release the lock when disconnecting, and push it in fully till the works when connecting it.
- When disconnecting the coupler, be sure to hold the coupler body and do not pull the lead wires.
- Inspect each terminal on the connector/coupler for looseness or bending.
- Inspect each terminal for corrosion and contamination. The terminals must be clean and free of any foreign material which could impede proper terminal contact.
- Inspect each lead wire circuit for poor connection by shaking it by hand lightly. If any abnormal condition is found, repair or replace.

When taking measurements at electrical connectors using a tester probe, be sure to insert the probe from the wire harness side (backside) of the connector/coupler.

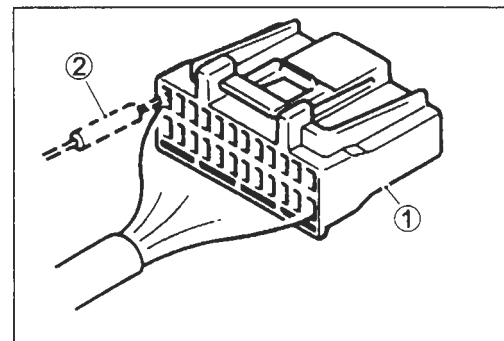
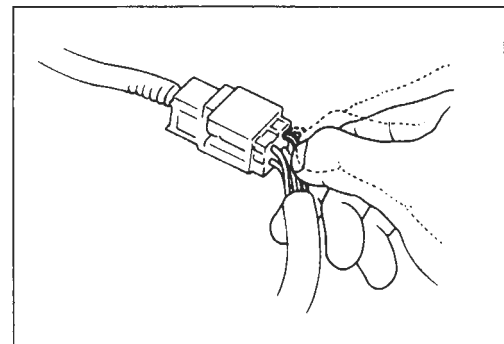
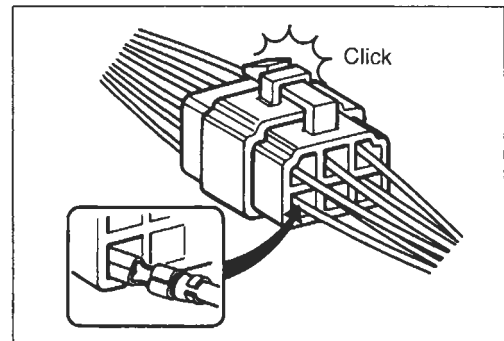
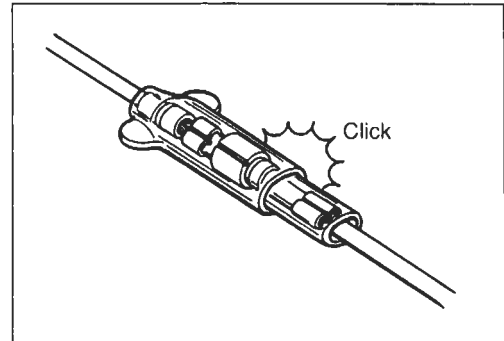

- ① Coupler
- ② Probe

- When connecting meter probe from the terminal side of the coupler (connection from harness side not being possible), use extra care not to force and cause the male terminal to bend or the female terminal to open. Connect the probe as shown to avoid opening of female terminal.
- Never push in the probe where male terminal is supposed to fit.
- Check the male connector for bend and female connector for excessive opening. Also check the coupler for locking (looseness), corrosion, dust, etc.

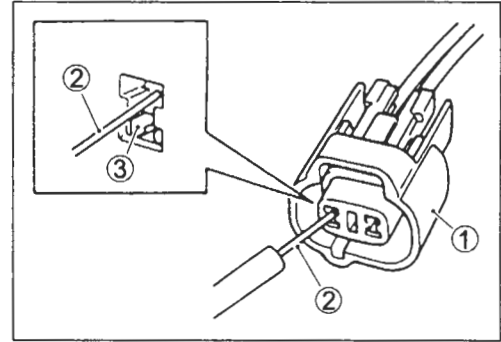

- ① Coupler
- ② Probe
- ③ Where male terminal fits.

**FUSE**

- When a fuse blows, always investigate the cause correct it and then replace the fuse.
- Do not use a fuse of a different capacity.
- Do not use wire or any other substitute for the fuse.

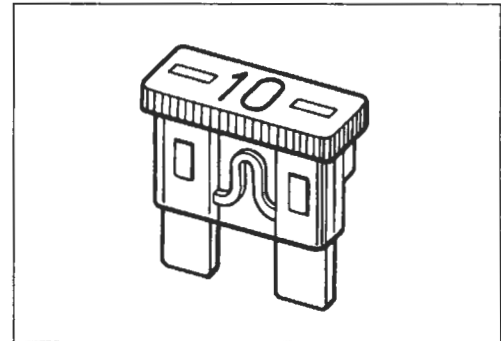

**ECM/VARIOUS SENSORS**

- Since each component is a high-precision part, great care should be taken not to apply any sharp impacts during removal and installation.

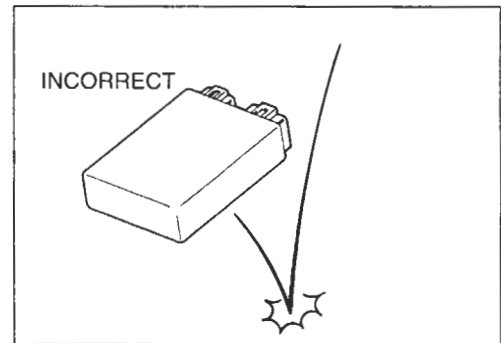

- Be careful not to touch the electrical terminals of the ECM. The static electricity from your body may damage this part.

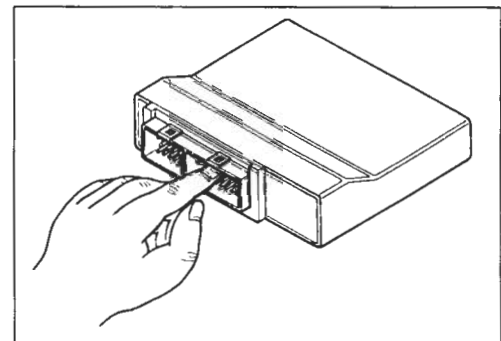

- When disconnecting and connecting the ECM, make sure to turn OFF the ignition switch ①, or electronic parts may get damaged.

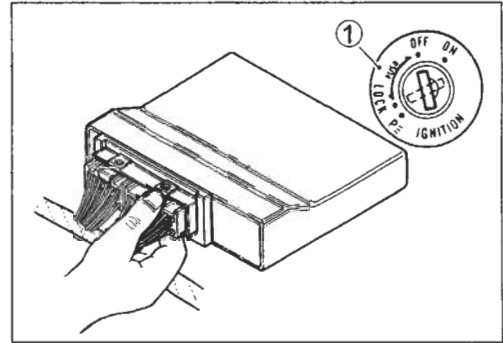

- Battery connection in reverse polarity is strictly prohibited. Such a wrong connection will damage the components of the FI system instantly when reverse power is applied.

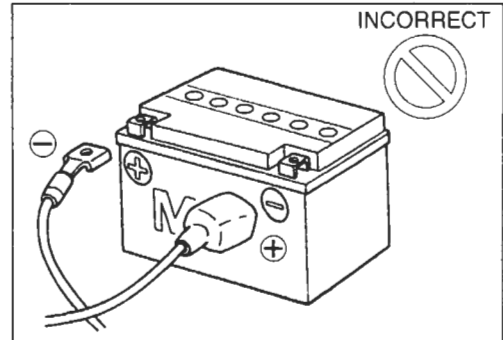

- Removing any battery terminal of a running engine is strictly prohibited. The moment such removal is made, damaging counter electromotive force will be applied to the ECM which may result in serious damage.

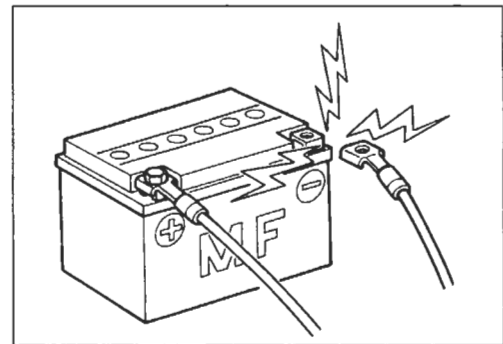

- Before measuring voltage at each terminal, check to make sure that battery voltage is 11 V or higher. Terminal voltage check at low battery voltage will lead to erroneous diagnosis.

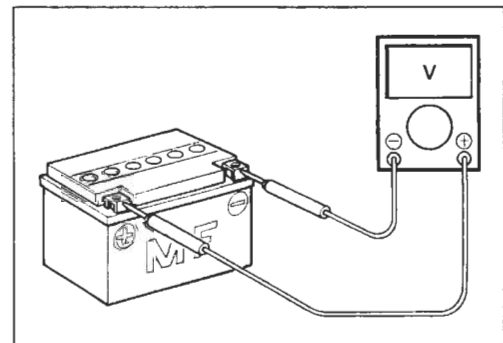

- Never connect any tester (voltmeter, ohmmeter, or whatever) to the ECM when its coupler is disconnected. Otherwise, damage to ECM may result.
- Never connect an ohmmeter to the ECM with its coupler connected. If attempted, damage to ECM or sensors may result.
- Be sure to use a specified voltmeter/ohmmeter. Otherwise, accurate measurements may not be obtained and personal injury may result.

## ELECTRICAL CIRCUIT INSPECTION PROCEDURE

While there are various methods for electrical circuit inspection, described here is a general method to check for open and short circuit using an ohmmeter and a voltmeter.

### OPEN CIRCUIT CHECK

Possible causes for the open circuits are as follows. As the cause can exist in the connector/coupler or terminal, they need to be checked carefully.

- Loose connection of connector/coupler.
- Poor contact of terminal (due to dirt, corrosion or rust, poor contact tension, entry of foreign object etc.).
- Wire harness being open.
- Poor terminal-to-wire connection.
- Disconnect the negative cable from the battery.
- Check each connector/coupler at both ends of the circuit being checked for loose connection. Also check for condition of the coupler lock if equipped.

- ① Sensor
- ② ECM
- Ⓐ Check for loose connection.

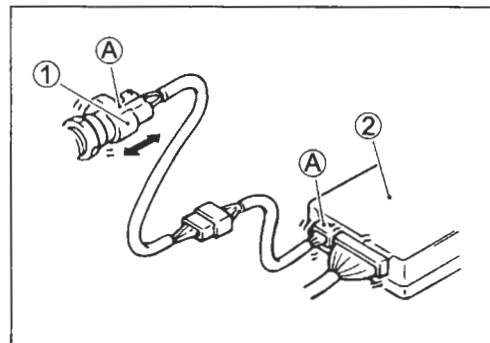

- Using a test male terminal, check the female terminals of the circuit being checked for contact tension.

Check each terminal visually for poor contact (possibly caused by dirt, corrosion, rust, entry of foreign object, etc.). At the same time, check to make sure that each terminal is fully inserted in the coupler and locked.

If contact tension is not enough, rectify the contact to increase tension or replace.

The terminals must be clean and free of any foreign material which could impede proper terminal contact.

- Ⓐ Check contact tension by inserting and removing.
- Ⓑ Check each terminal for bend and proper alignment.

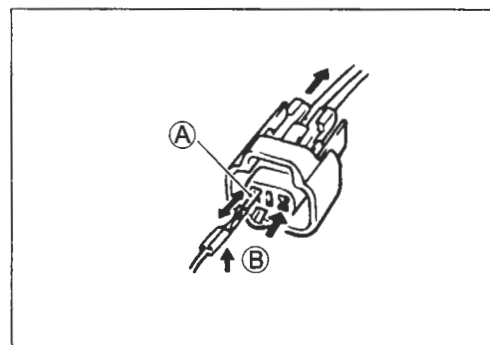

- Using continuity inspect or voltage check procedure as described below, inspect the wire harness terminals for open circuit and poor connection. Locate abnormality, if any.

- ① Looseness of crimping
- ② Open
- ③ Thin wire (a few strands left)

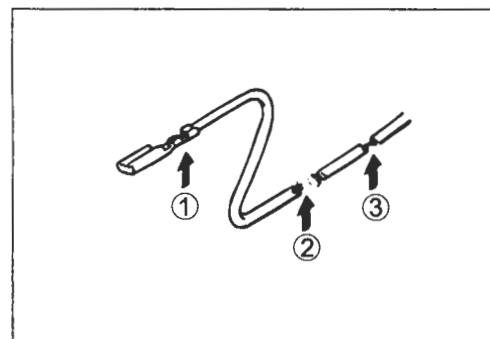

**Continuity check**

- Measure resistance across coupler **B** (between **A** and **C** in the figure).

If no continuity is indicated (infinity or over limit), the circuit is open between terminals **A** and **C**.

① ECM

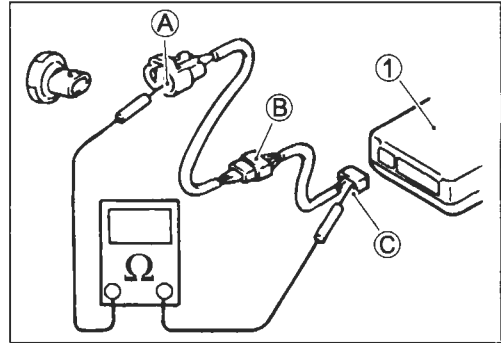

- Disconnect the coupler **B** and measure resistance between couplers **A** and **B**.

If no continuity is indicated, the circuit is open between couplers **A** and **B**. If continuity is indicated, there is an open circuit between couplers **B'** and **C** or an abnormality in coupler **B'** or coupler **C**.

① ECM

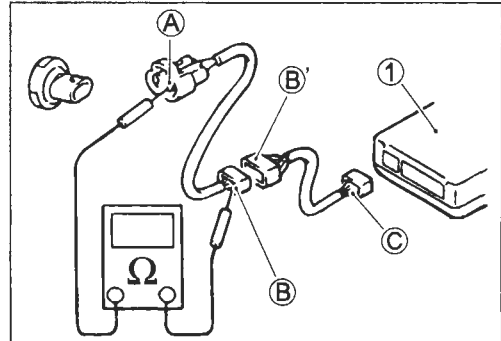

**VOLTAGE CHECK**

If voltage is supplied to the circuit being checked, voltage check can be used as circuit check.

- With all connectors/couplers connected and voltage applied to the circuit being checked, measure voltage between each terminal and body ground.

If measurements were taken as shown in the figure at the right and results are as listed below, it means that the circuit is open between terminals **A** and **B**.

**Voltage Between:**

- **C** and body ground: Approx. 5 V
- **B** and body ground: Approx. 5 V
- **A** and body ground: 0 V

Also, if measured values are as listed below, a resistance (abnormality) exists which causes the voltage drop in the circuit between terminals **A** and **B**.

**Voltage Between:**

- **C** and body ground: Approx. 5 V
- **B** and body ground: Approx. 5 V — 2 V voltage drop
- **A** and body ground: 3 V —

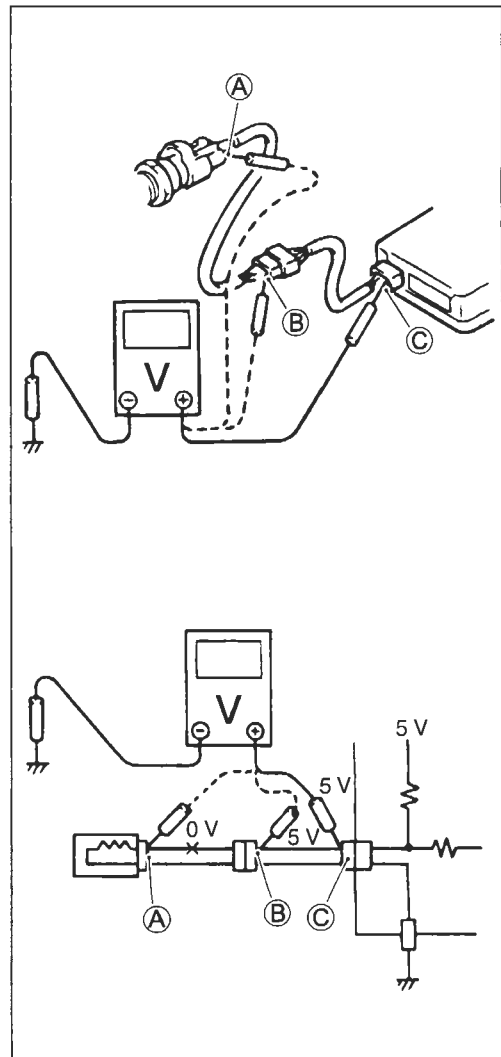

**SHORT CIRCUIT CHECK (WIRE HARNESS TO GROUND)**

- Disconnect the negative cable from the battery.
- Disconnect the connectors/couplers at both ends of the circuit to be checked.

**NOTE:**

*If the circuit to be checked branches to other parts as shown, disconnect all connectors/couplers of those parts. Otherwise, diagnosis will be misled.*

- Measure resistance between terminal at one end of circuit (A terminal in figure) and body ground. If continuity is indicated, there is a short circuit to ground between terminals (A) and (C).
  - ① To other parts.
  - ② Other parts

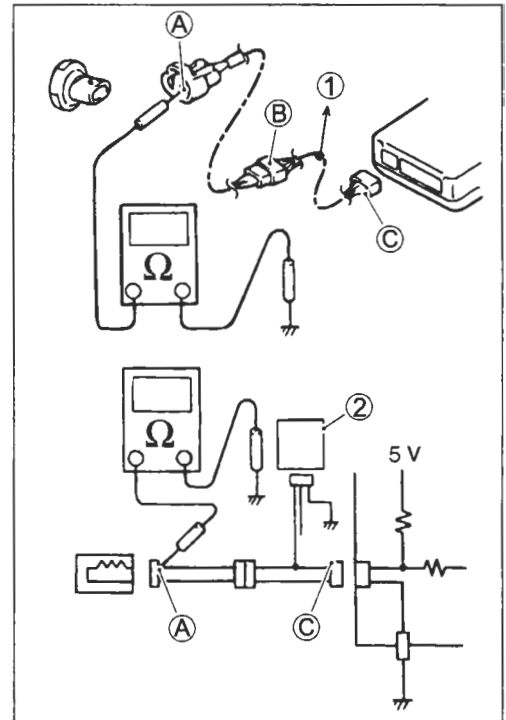

- Disconnect the connector/coupler included in circuit (coupler (B)) and measure resistance between terminal (A) and body ground. If continuity is indicated, the circuit is shorted to the ground between terminals (A) and (B).

- ① To other parts.
- ② ECM

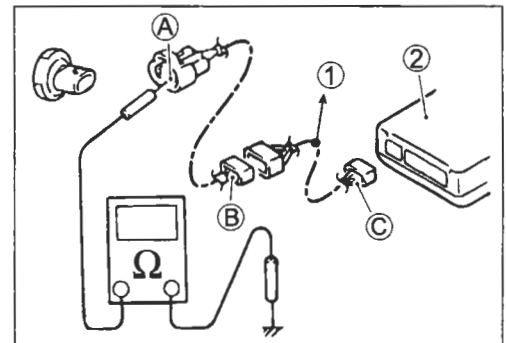

## USING TESTERS

- Use the Suzuki multi-circuit tester set (09990-25008).
- Use well-charged batteries in the tester.
- Be sure to set the tester to the correct testing range.

### USING THE TESTER

- Incorrectly connecting the  $\oplus$  and  $\ominus$  probes may cause the inside of the tester to burnout.
- If the voltage and current are not known, make measurements using the highest range.
- When measuring the resistance with the multi-circuit tester ①,  $\infty$  will be shown as 10.00 M $\Omega$  and "1" flashes in the display.
- Check that no voltage is applied before making the measurement. If voltage is applied the tester may be damaged.
- After using the tester, turn the power off.

#### 09990-25008: Multi-circuit tester set

#### NOTE:

- \* When connecting the multi-circuit tester, use the needle pointed probe to the back side of the lead wire coupler and connect the probes of tester to them.
- \* Use the needle pointed probe to prevent the rubber of the water proof coupler from damage.

#### 09990-25009: Needle pointed probe set

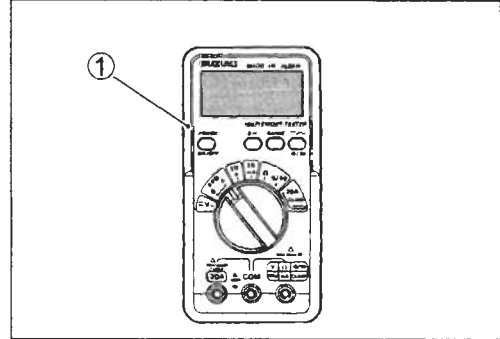



## FI SYSTEM TECHNICAL FEATURES

### INJECTION TIME (INJECTION VOLUME)

The factors to determine the injection time include the basic fuel injection time, which is calculated on the basis of intake air pressure, engine speed and throttle opening angle, and various compensations.

These compensations are determined according to the signals from various sensors that detect the engine and driving conditions.

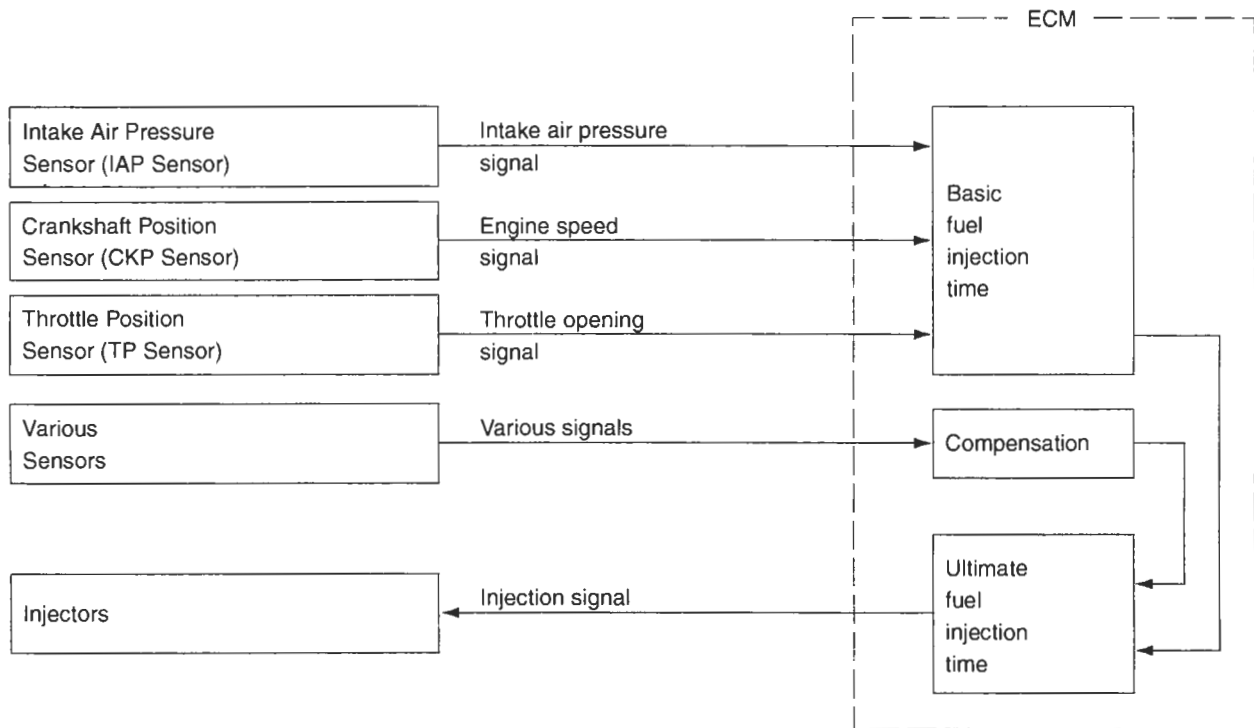

## COMPENSATION OF INJECTION TIME (VOLUME)

The following different signals are output from the respective sensors for compensation of the fuel injection time (volume).

SIGNAL	DESCRIPTION
ENGINE COOLANT TEMPERATURE SENSOR SIGNAL	When engine coolant temperature is low, injection time (volume) is increased.
INTAKE AIR TEMPERATURE SENSOR SIGNAL	When intake air temperature is low, injection time (volume) is increased.
BATTERY VOLTAGE SIGNAL	ECM operates on the battery voltage and at the same time, it monitors the voltage signal for compensation of the fuel injection time (volume). A longer injection time is needed to adjust injection volume in the case of low voltage.
ENGINE RPM SIGNAL	At high speed, the injection time (volume) is increased.
ACCELERATION SIGNAL/ DECELERATION SIGNAL	During acceleration, the fuel injection time (volume) is increased in accordance with the throttle opening speed and engine rpm. During deceleration, the fuel injection time (volume) is decreased.

## INJECTION STOP CONTROL

SIGNAL	DESCRIPTION
TIP OVER SENSOR SIGNAL (FUEL SHUT-OFF)	When the motorcycle tips over, the tip over sensor sends a signal to the ECM. Then, this signal cuts OFF current supplied to the fuel pump, fuel injector and ignition coil.
OVER-REV. LIMITER SIGNAL	The fuel injectors stop operation when engine rpm reaches rev. limit rpm.

## FI SYSTEM PARTS LOCATION

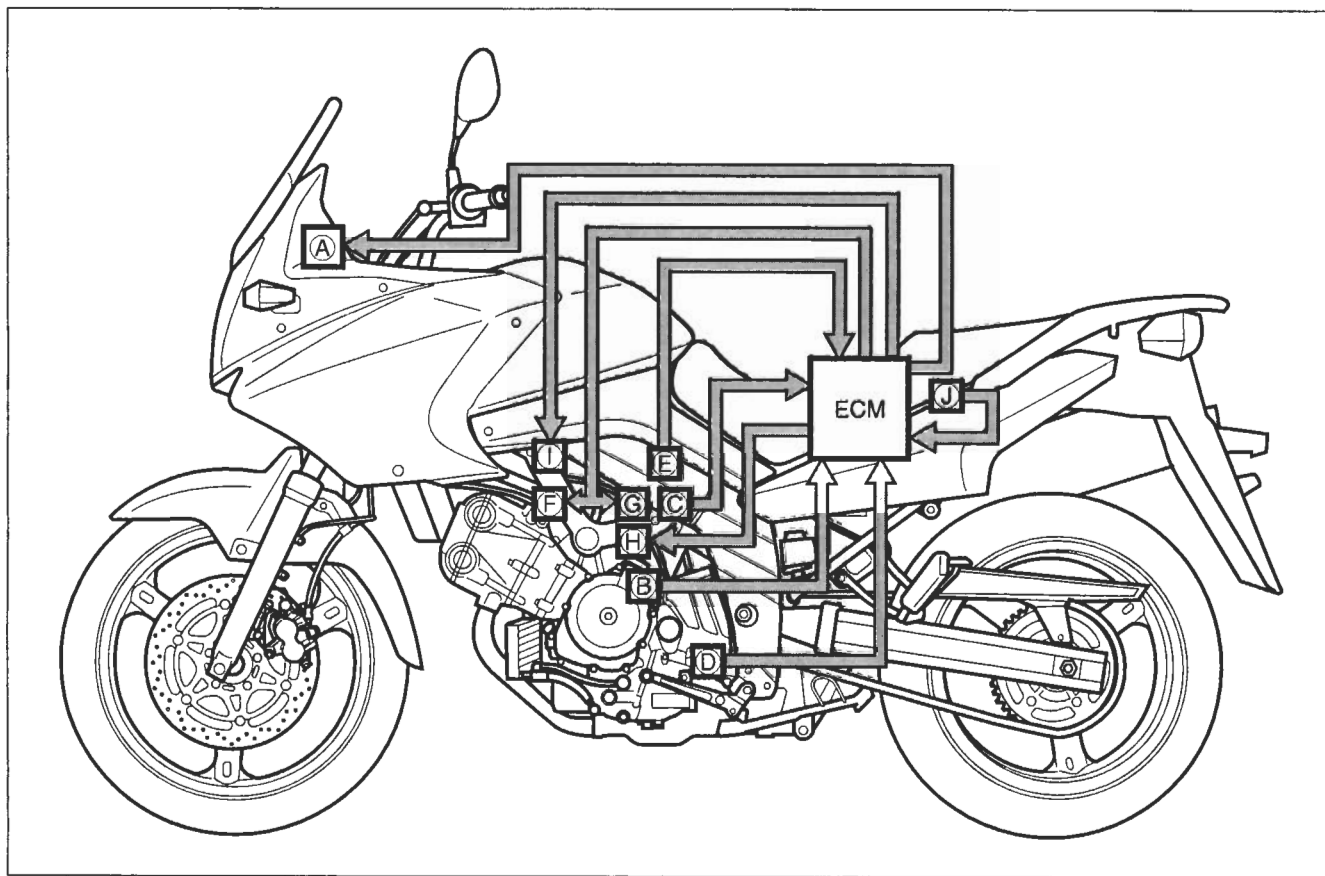

- |                        |                       |
|------------------------|-----------------------|
| Ⓐ Speedometer          | Ⓕ Fuel injector, No.1 |
| Ⓑ CKP sensor           | Ⓖ Fuel injector, No.2 |
| Ⓒ TP sensor            | Ⓗ Ignition coil, No.1 |
| Ⓓ Gear position sensor | Ⓘ STVA                |
| Ⓔ STP sensor           | ⓵ TO sensor           |

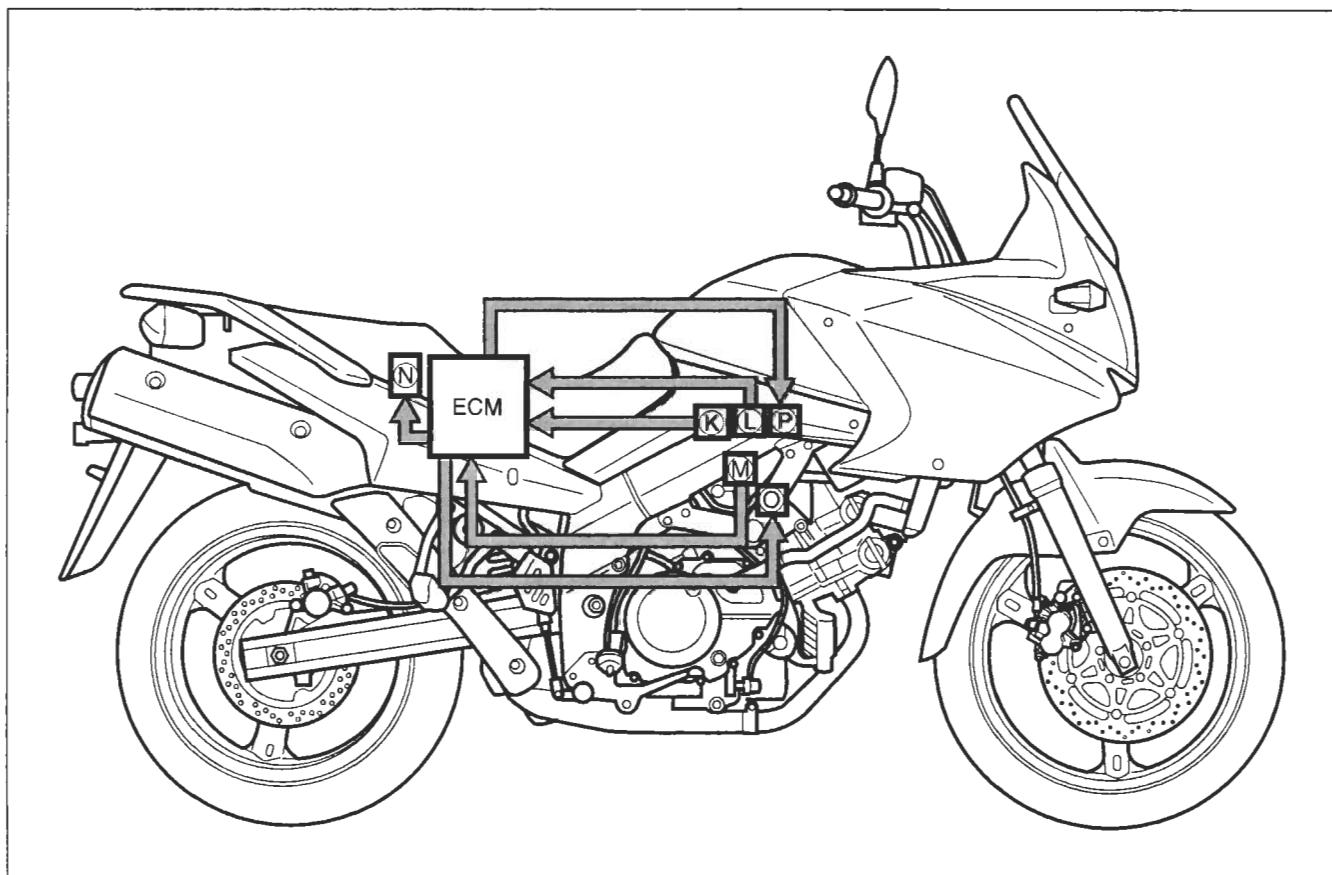

- Ⓚ IAP sensor
- Ⓛ IAT sensor
- Ⓜ ECT sensor

- Ⓝ Fuel pump relay
- Ⓞ Ignition coil, No.2
- Ⓟ PAIR control valve

# FI SYSTEM WIRING DIAGRAM

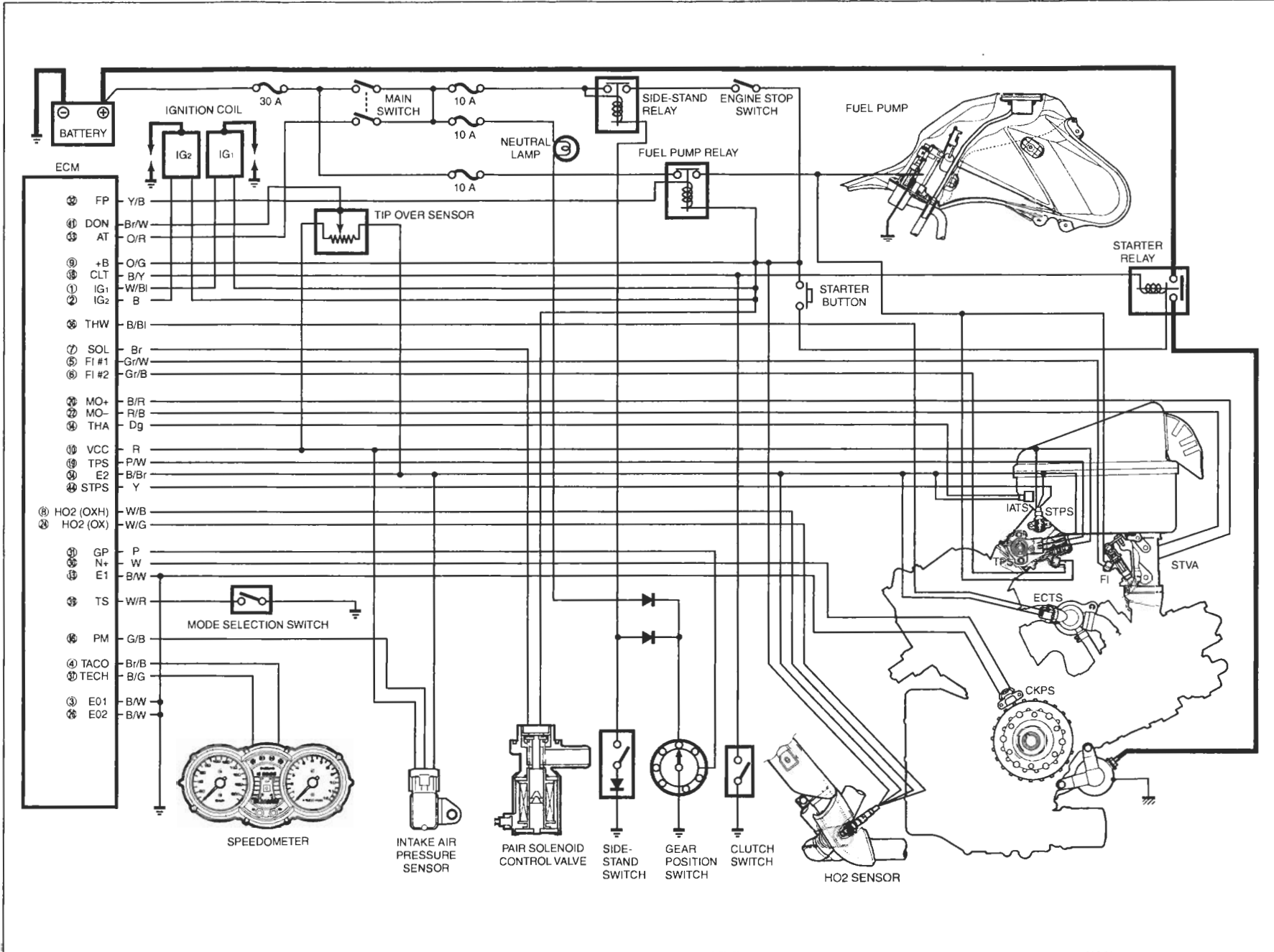

## SELF-DIAGNOSIS FUNCTION

The self-diagnosis function is incorporated in the ECM. The function has two modes, "USER MODE" and "DEALER MODE". The user can only be notified by the LCD (DISPLAY) panel and LED (FI light). To check the function of the individual FI system devices, the dealer mode is prepared. In this check, the special tool is necessary to read the code of the malfunction items.

### USER MODE

MALFUNCTION	LCD (DISPLAY) INDICATION	FI LIGHT INDICATION	INDICATION MODE
"NO"	Clock	—	—
"YES"	Clock and "FI" letters	FI light turns ON.	Each 2 sec. Clock or "FI" is indicated.
Engine can start	*1		
Engine can not start	"FI" letters *2	FI light turns ON and blinks.	"FI" is indicated continuously.

\*1

When one of the signals is not received by ECM, the fail-safe circuit works and injection is not stopped. In this case, "FI" and clock are indicated in the LCD panel and motorcycle can run.

\*2

The injection signal is stopped, when the crankshaft position sensor signal, tip over sensor signal, #1/#2 ignition signals, #1/#2 injector signals, fuel pump relay signal or ignition switch signal is not sent to ECM. In this case, "FI" is indicated in the LCD panel. Motorcycle does not run.

"CHEC": The LCD panel indicates "CHEC" when no communication signal from the ECM is received for 3 seconds.

For Example, The ignition switch is turned ON, and the engine stop switch is turned OFF. In this case, the speed-meter does not receive any signal from ECM, and the panel indicates "CHEC".

If CHEC is indicated, the LCD does not indicate the trouble code. It is necessary to check the wiring harness between ECM and speedometer couplers.

The possible cause of this indication is as follows;

Engine stop switch is in OFF position. Side-stand/ignition inter-lock system is not working Ignition fuse is burnt.

#### NOTE:

*Until starting the engine, the FI light turns ON.*

*The FI light is also turned ON when engine temperature is high or oil pressure is low.*

## DEALER MODE

The defective function is memorized in the computer. Use the special tool's coupler to connect to the dealer mode coupler. (☞ 4-20) The memorized malfunction code is displayed on LCD (DISPLAY) panel. Malfunction means that the ECM does not receive signal from the devices. These affected devices are indicated in the code form.

 **09930-82720: Mode select switch**

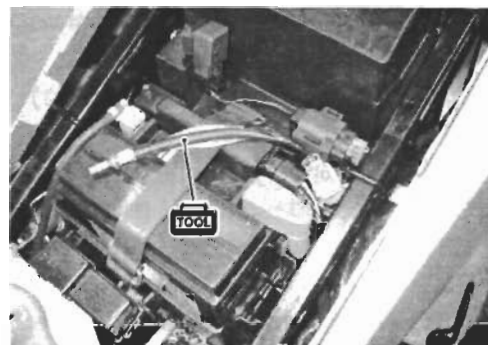

### CAUTION

- \* Do not disconnect the ECM lead wire couplers, before checking the malfunction code, or the malfunction code memory is erased and the malfunction code can not be checked.
- \* Confirm the malfunction code after ignition ON or cranking the engine for few seconds.

MALFUNCTION	LCD (DISPLAY) INDICATION	FI LIGHT INDICATION	INDICATION MODE
"NO"	C00	"FI" letter turns OFF.	—
"YES"	C**code is indicated from small numeral to large one.		For each 2 sec., code is indicated.

CODE	MALFUNCTION PART	REMARKS
C00	None	No defective part
C12	Crankshaft position sensor (CKPS)	Pick-up coil signal, signal generator
C13	Intake air pressure sensor (IAPS)	
C14	Throttle position sensor (TPS)	
C15	Engine coolant temperature sensor (ECTS)	
C21	Intake air temperature sensor (IATS)	
C23	Tip over sensor (TOS)	
C24	Ignition signal #1 (IG coil #1)	For #1 cylinder
C25	Ignition signal #2 (IG coil #2)	For #2 cylinder
C28	Secondary throttle valve actuator (STVA)	
C29	Secondary throttle position sensor (STPS)	
C31	Gear position signal (GP switch)	
C32	Fuel injector signal #1	For #1 cylinder
C33	Fuel injector signal #2	For #2 cylinder
C41	Fuel pump control system (FP control system)	Fuel pump, Fuel pump relay
C42	Ignition switch signal (IG switch signal)	Anti-theft
C44	Heated oxygen sensor (HO2S)	For E-02, 19
C49	PAIR control solenoid valve	

In the LCD (DISPLAY) panel, the malfunction code is indicated from small code to large code.

## TPS ADJUSTMENT

- Warm up the engine and adjust the engine idle speed to  $1\,300 \pm 100$  rpm. (☞ 2-15)
- Stop the engine.
- Connect the special tool (Mode select switch) and select the dealer mode.
- If the throttle position sensor adjustment is necessary, loosen the screws and turn the throttle position sensor and bring the line to middle.
- Then, tighten the screw to fix the throttle position sensor.



 TP sensor mounting screw: 3.5 N·m (0.35 kgf-m, 2.5 lb-ft)

- Ⓐ Incorrect  
Ⓑ Correct position

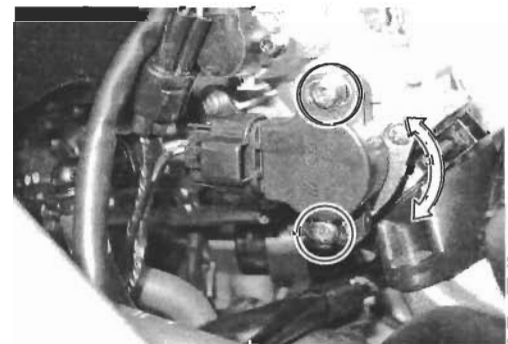
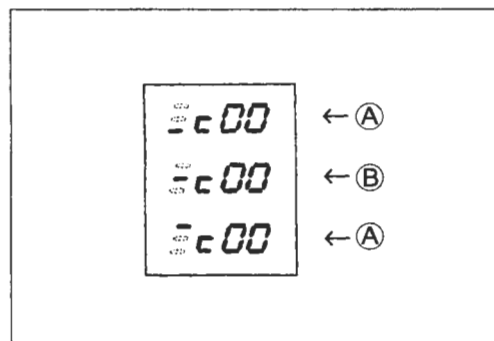

 09930-11950: Torx wrench  
09930-82720: Mode select switch



## FAIL-SAFE FUNCTION

FI system is provided with fail-safe function to allow the engine to start and the motorcycle to run in a minimum performance necessary even under malfunction condition.

ITEM	FAIL-SAFE MODE	STARTING ABILITY	RUNNING ABILITY
Intake air pressure sensor	Intake air pressure and atmospheric pressure are fixed to 760 mmHg.	"YES"	"YES"
Throttle position sensor	The throttle opening signal is fixed to full open position, and STV is fixed at 1/2 open position. Ignition timing is also fixed.	"NO"	"YES"
Engine coolant temperature sensor	Engine coolant temperature value is fixed to 80 °C (176 °F).	"YES"	"YES"
Intake air temperature sensor	Intake air temperature value is fixed to 40 °C (104 °F).	"YES"	"YES"
Ignition signal	#1 #1 Fuel cut	"YES"	"YES"
	#2 #2 Fuel cut	"YES"	"YES"
Injection signal	#1 #1 Fuel-cut	"YES"	"YES"
	#2 #2 Fuel-cut	"YES"	"YES"
Secondary throttle valve actuator	ECM stops controlling STV.	"YES"	"YES"
Secondary throttle position sensor	ECM stops controlling STV.	"YES"	"YES"
Gear position signal	Gear position signal is fixed to 4th gear.	"YES"	"YES"
Heated oxygen sensor (E-02, 19)	Fuel-air compensation ratio is fixed to normal condition.	"YES"	"YES"
PAIR control solenoid valve	ECM stops controlling PAIR control solenoid valve.	"YES"	"YES"

The engine can start and can run even if the above signal is not received from each sensor. But, the engine running condition is not complete, providing only emergency help (by fail-safe circuit). In this case, it is necessary to bring the motorcycle to the workshop for complete repair.

## FI SYSTEM TROUBLESHOOTING CUSTOMER COMPLAINT ANALYSIS

Record details of the problem (failure, complaint) and how it occurred as described by the customer. For this purpose, use of such an inspection form will facilitate collecting information to the point required for proper analysis and diagnosis.

### EXAMPLE: CUSTOMER PROBLEM INSPECTION FORM

User name:	Model:	VIN:	
Date of issue:	Date Reg.	Date of problem:	Mileage:

Malfunction indicator lamp condition (LED)	<input type="checkbox"/> Always ON <input type="checkbox"/> Sometimes ON <input type="checkbox"/> Always OFF <input type="checkbox"/> Good condition
Malfunction display/code (LCD)	User mode: <input type="checkbox"/> No display <input type="checkbox"/> Malfunction display (            )
	Dealer mode: <input type="checkbox"/> No code <input type="checkbox"/> Malfunction code (            )

PROBLEM SYMPTOMS	
<input type="checkbox"/> <b>Difficult Starting</b> <input type="checkbox"/> No cranking <input type="checkbox"/> No initial combustion <input type="checkbox"/> No combustion <input type="checkbox"/> Poor starting at ( <input type="checkbox"/> cold <input type="checkbox"/> warm <input type="checkbox"/> always) <input type="checkbox"/> Other _____	<input type="checkbox"/> <b>Poor Driveability</b> <input type="checkbox"/> Hesitation on acceleration <input type="checkbox"/> Back fire/ <input type="checkbox"/> After fire <input type="checkbox"/> Lack of power <input type="checkbox"/> Surging <input type="checkbox"/> Abnormal knocking <input type="checkbox"/> Engine rpm jumps briefly <input type="checkbox"/> Other _____
<input type="checkbox"/> <b>Poor Idling</b> <input type="checkbox"/> Poor fast Idle <input type="checkbox"/> Abnormal idling speed ( <input type="checkbox"/> High <input type="checkbox"/> Low) (            r/min) <input type="checkbox"/> Unstable <input type="checkbox"/> Hunting (            r/min. to            r/min) <input type="checkbox"/> Other _____	<input type="checkbox"/> <b>Engine Stall when</b> <input type="checkbox"/> Immediately after start <input type="checkbox"/> Throttle valve is opened <input type="checkbox"/> Throttle valve is closed <input type="checkbox"/> Load is applied <input type="checkbox"/> Other _____
<input type="checkbox"/> OTHERS:	

<b>MOTORCYCLE/ENVIRONMENTAL CONDITION WHEN PROBLEM OCCURS</b>	
<b>Environmental condition</b>	
Weather	<input type="checkbox"/> Fair <input type="checkbox"/> Cloudy <input type="checkbox"/> Rain <input type="checkbox"/> Snow <input type="checkbox"/> Always <input type="checkbox"/> Other
Temperature	<input type="checkbox"/> Hot <input type="checkbox"/> Warm <input type="checkbox"/> Cool <input type="checkbox"/> Cold (    °F/    °C) <input type="checkbox"/> Always
Frequency	<input type="checkbox"/> Always <input type="checkbox"/> Sometimes (    times/    day, month) <input type="checkbox"/> Only once
	<input type="checkbox"/> Under certain condition
Road	<input type="checkbox"/> Urban <input type="checkbox"/> Suburb <input type="checkbox"/> Highway <input type="checkbox"/> Mountainous ( <input type="checkbox"/> Uphill <input type="checkbox"/> Downhill)
	<input type="checkbox"/> Tarmacadam <input type="checkbox"/> Gravel <input type="checkbox"/> Other
<b>Motorcycle condition</b>	
Engine condition	<input type="checkbox"/> Cold <input type="checkbox"/> Warming up phase <input type="checkbox"/> Warmed up <input type="checkbox"/> Always <input type="checkbox"/> Other at starting
	<input type="checkbox"/> Immediately after start <input type="checkbox"/> Racing without load <input type="checkbox"/> Engine speed (    r/min)
Motorcycle condition	During driving: <input type="checkbox"/> Constant speed <input type="checkbox"/> Accelerating <input type="checkbox"/> Decelerating
	<input type="checkbox"/> Right hand corner <input type="checkbox"/> Left hand corner <input type="checkbox"/> At stop
	<input type="checkbox"/> Motorcycle speed when problem occurs (    km/h,    Mile/h)
	<input type="checkbox"/> Other _____

**NOTE:**

\* The above form is a standard sample. It should be modified according to conditions characteristic of each market.

## SELF-DIAGNOSTIC PROCEDURES

Don't disconnect couplers from ECM, battery cable from battery, ECM ground wire harness from engine or main fuse before confirming malfunction code (self-diagnostic trouble code) stored in memory. Such disconnection will erase memorized information in ECM memory.

Malfunction code stored in ECM memory can be checked by the special tool.

Before checking malfunction code, read SELF-DIAGNOSIS FUNCTION "USER MODE and DEALER MODE" (☞ 4-14, 15) carefully to have good understanding as to what functions are available and how to use it.

Be sure to read "PRECAUTIONS for Electrical Circuit Service" (☞ 4-2) before inspection and observe what is written there.

- Remove the seat. (☞ 7-4)
- Connect the special tool to the dealer mode coupler at the wiring harness, and start the engine or crank the engine for 4 seconds and more.
- Turn the special tool's switch ON and check the malfunction code to determine the malfunction part.

 **09930-82720: Mode select switch**

### NOTE:

The dealer mode coupler is located inside of the left frame cover.

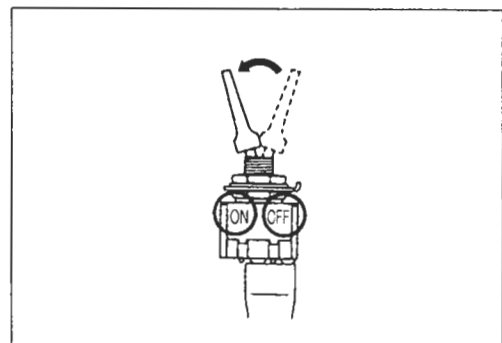
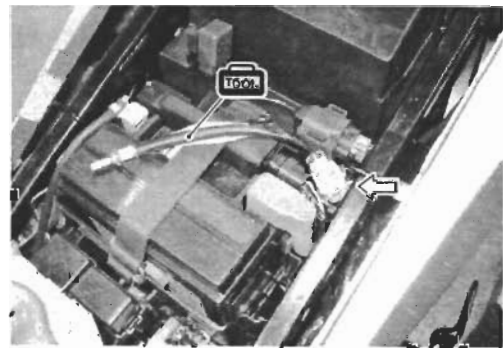

## SELF-DIAGNOSIS RESET PROCEDURE

- After repairing the trouble, turn OFF the ignition switch and turn ON again.
- If C00 is indicated, the malfunction codes are cleared.
- Disconnect the special tool from the dealer mode coupler.



## MALFUNCTION CODE AND DEFECTIVE CONDITION

MALFUNCTION CODE	DETECTED ITEM	DETECTED FAILURE CONDITION
		CHECK FOR
C00	NO FAULT	
C12	Crankshaft position sensor	The signal does not reach ECM for 3 sec. and more, after receiving the IAP signal.
		The crankshaft position sensor wiring and mechanical parts. (Crankshaft position sensor, lead wire/coupler connection)
C13	Intake air pressure sensor	The sensor should produce following voltage. $0.1 \text{ V} \leq \text{sensor voltage} \leq 4.8 \text{ V}$ Without the above range for 4 sec. and more, C13 is indicated.
		Intake air pressure sensor, lead wire/coupler connection.
C14	Throttle position sensor	The sensor should produce following voltage. $0.1 \text{ V} \leq \text{sensor voltage} < 4.8 \text{ V}$ Without the above range for 4 sec. and more, C14 is indicated.
		Throttle position sensor, lead wire/coupler connection.
C15	Engine coolant temperature sensor	The sensor voltage should be the following. $0.1 \text{ V} \leq \text{sensor voltage} < 4.6 \text{ V}$ Without the above range for 4 sec. and more, C15 is indicated.
		Engine coolant temperature sensor, lead wire/coupler connection.
C21	Intake air temperature sensor	The sensor voltage should be the following. $0.1 \text{ V} \leq \text{sensor voltage} < 4.6 \text{ V}$ Without the above range for 4 sec. and more, C21 is indicated.
		Intake air temperature sensor, lead wire/coupler connection.
C23	Tip over sensor	The sensor voltage should be the following for 2 sec. and more after ignition switch turns ON. $0.2 \text{ V} \leq \text{sensor voltage} \leq 4.6 \text{ V}$ Without the above value for 2 sec. and more, C23 is indicated.
		Tip over sensor, lead wire/coupler connection.
C24/C25	Ignition signal #1/#2	Crankshaft position sensor (pick-up coil) signal is produced, but signal from ignition coil is interrupted continuous by 8 times or more. In this case, the code C24 or C25 is indicated.
		Ignition coil, wiring/coupler connection, power supply from the battery.

MALFUNCTION CODE	DETECTED ITEM	DETECTED FAILURE CONDITION
		CHECK FOR
C28	Secondary throttle valve actuator	When no actuator control signal is supplied from the ECM or communication signal does not reach ECM or operation voltage does not reach STVA motor, C28 is indicated. STVA can not operate. STVA lead wire/coupler.
C29	Secondary throttle position sensor	The sensor should produce following voltage. $0.1 \text{ V} \leq \text{sensor voltage} \leq 4.8 \text{ V}$ Without the above range for 4 sec. and more, C29 is indicated. Secondary throttle position sensor, lead wire/coupler connection.
C31	Gear position signal	It judges from gear position voltage, engine speed and throttle position by ECM, when the gear position voltage is 0.2 V and less. Gear position sensor, wiring/coupler connection. Gearshift cam etc.
C32/C33	Fuel injector #1/#2	When fuel injector voltage gets 1.3 V and less, C32 or C33 is indicated. Injector, wiring/coupler connection, power supply to the injector.
C41	Fuel pump relay	No voltage is applied to the both injectors #1/#2 for 3 sec. after the contact of fuel pump relay is turned ON. Or voltage is applied to the both injectors #1/#2, when the contact of fuel pump is OFF. Fuel pump relay, connecting lead wire, power source to fuel pump relay, fuel injectors.
C42	Ignition switch	Ignition switch signal is not input in ECM. Ignition switch, lead wire/coupler.
C44	Heated oxygen sensor (HO2S) [E-02, 19]	The sensor voltage should be the following and less after warming up condition. (Sensor voltage $\leq 0.4 \text{ V}$ ) Without the above value, C44 is indicated. Heater operation voltage does not reach in the oxygen heater circuit, C44 in indicated. The Heater can not operate. HO2S lead wire/coupler connection. Battery voltage supply to the HO2S.
C49	PAIR control solenoid valve	PAIR control solenoid valve voltage is not input in ECM. PAIR control solenoid valve, lead wire/coupler.

## “C12” CKP SENSOR CIRCUIT MALFUNCTION

DETECTED CONDITION	POSSIBLE CAUSE
The signal does not reach ECM for 3 sec. and more, after receiving the IAP signal.	<ul style="list-style-type: none"> <li>• Metal particles or foreign materiel being attached on the CKP sensor and rotor tip.</li> <li>• CKP sensor circuit open or short.</li> <li>• CKP sensor malfunction.</li> <li>• ECM malfunction.</li> </ul>

### INSPECTION

#### Step1

- 1) Turn the ignition switch OFF.
- 2) Check the CKP sensor coupler ① for loose or poor contacts.  
If OK, then measure the CKP sensor resistance.



- 3) Disconnect the CKP sensor coupler and measure the resistance.

**DATA** CKP sensor resistance: 130 – 240 Ω  
(White – Green)

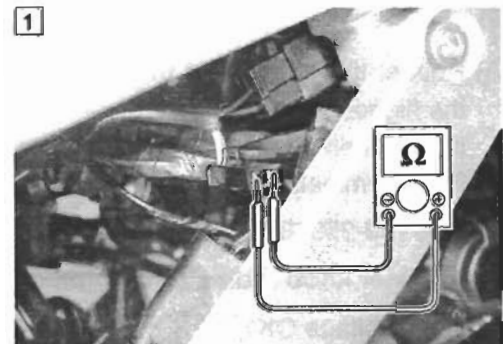

- 4) If OK, then check the continuity between each terminal and ground.

**DATA** CKP sensor continuity: ∞ Ω (Infinity)  
(White – Ground)  
(Green – Ground)

**TOOL** 09900-25008: Multi circuit tester set

**Tester knob indication: Resistance (Ω)**

Are the resistance and continuity OK?

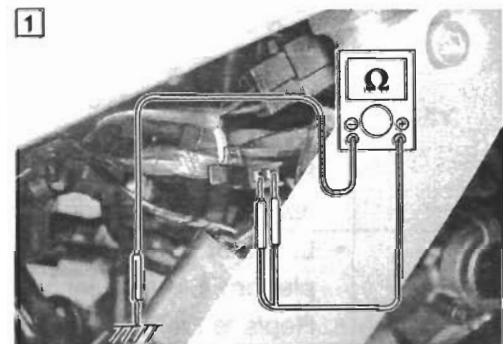

YES	Go to Step 2.
NO	Replace the CKP sensor with a new one.

**Step2**

1) Disconnect the CKP sensor coupler.

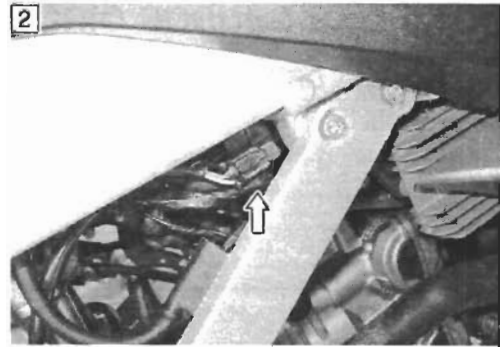

2) Crank the engine a few seconds with the starter motor, and measure the CKP sensor peak voltage at the coupler.

**DATA** CKP sensor peak voltage: **3.7 V and more**  
 (+ White - - Green)

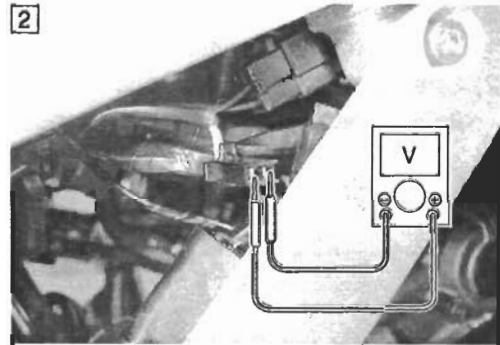

3) Repeat the above test procedure a few times and measure the highest peak voltage.

If OK, then measure the CKP sensor peak voltage at the ECM terminals. (26 - 30)

**TOOL** 09900-25008: Multi circuit tester set

**Tester knob indication: voltage (---)**

Is the voltage OK?

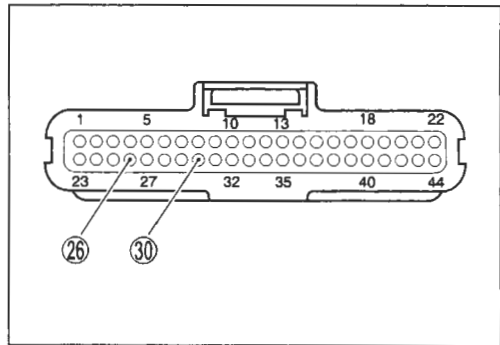

YES	<ul style="list-style-type: none"> <li>• B/W or White wire open or shorted to ground, or poor 26 or 30 connection.</li> <li>• If wire and connection are OK, intermittent trouble or faulty ECM.</li> <li>• Recheck each terminal and wire harness for open circuit and poor connection.</li> </ul>
NO	<ul style="list-style-type: none"> <li>• Loose or poor contacts on the CKP sensor coupler or ECM coupler.</li> <li>• Replace the CKP sensor with a new one.</li> </ul>



## “C13” IAP SENSOR CIRCUIT MALFUNCTION

DETECTED CONDITION	POSSIBLE CAUSE
<p>IAP sensor voltage is out of the specified range.  <math>0.1\text{ V} \leq \text{Sensor voltage} \leq 4.8\text{ V}</math></p> <p><b>NOTE:</b>  <i>Note that atmospheric pressure varies depending on weather conditions as well as altitude.                      Take that into consideration when inspecting voltage.</i></p>	<ul style="list-style-type: none"> <li>• Clogged vacuum passage between throttle body and IAP sensor.</li> <li>• Air being drawn from vacuum passage between throttle body and IAP sensor.</li> <li>• IAP sensor circuit open or shorted to ground.</li> <li>• IAP sensor malfunction.</li> <li>• ECM malfunction.</li> </ul>

### INSPECTION

#### Step 1

- 1) Lift and support the fuel tank. (☞ 5-7)
- 2) Turn the ignition switch OFF.
- 3) Check the IAP sensor coupler for loose or poor contacts.  
 If OK, then measure the IAP sensor input voltage.

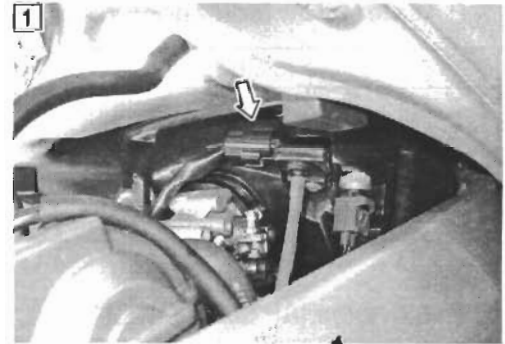

- 4) Disconnect the IAP sensor coupler.
- 5) Turn the ignition switch ON.
- 6) Measure the voltage at the Red wire ① and ground.  
 If OK, then measure the voltage at the Red wire ① and B/Br wire ②.

**DATA** IAP sensor input voltage: 4.5 – 5.5 V  
 (+ Red – – Ground)  
 (+ Red – – B/Br)

**TOOL** 09900-25008: Multi circuit tester set

**Tester knob indication: Voltage (---)**

Is the voltage OK?

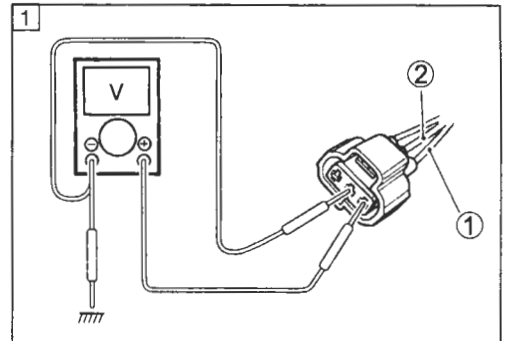

YES	Go to Step 2
NO	<ul style="list-style-type: none"> <li>• Loose or poor contacts on the ECM coupler.</li> <li>• Open or short circuit in the Red wire or B/Br wire.</li> </ul>

**Step 2**

- 1) Connect the IAP sensor coupler.
- 2) Insert the needle pointed probes to the lead wire coupler.
- 3) Start the engine at idle speed.
- 4) Measure the IAP sensor output voltage at the wire side coupler (between G/B and B/Br wires).

**DATA** IAP sensor output voltage: Approx. 2.7 V at idle speed  
(+ G/B - (-) B/Br)

**TOOL** 09900-25008: Multi circuit tester set  
09900-25009: Needle pointed probe set

**Tester knob indication: Voltage (V)**

YES	Go to Step 3
NO	<ul style="list-style-type: none"> <li>• Check the vacuum hose and the passage of throttle body vacuum for crack or damage.</li> <li>• Open or short circuit in the G/B wire.</li> <li>• Replace the IAP sensor with a new one.</li> </ul>

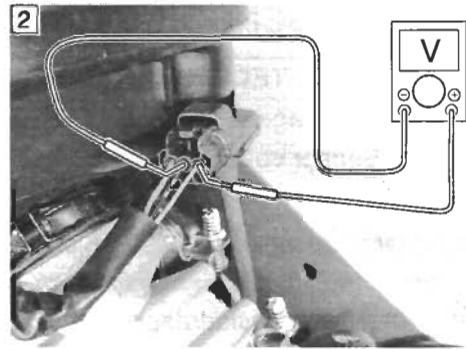

**Step 3**

- 1) Remove the IAP sensor. (4-49)
- 2) Connect the vacuum pump gauge to the vacuum port of the IAP sensor.

Arrange 3 new 1.5 V batteries in series ① (check that total voltage is 4.5 – 5.0 V) and connect (-) terminal to the ground terminal and (+) terminal to the Vcc ② terminal.

Check the voltage between Vout ③ and ground. Also, check if voltage reduces when vacuum is applied up to 400 mmHg by using vacuum pump gauge. (4-27)

**TOOL** 09917-47011: Vacuum pump gauge  
09900-25008: Multi circuit tester set

**Tester knob indication: Voltage (V)**

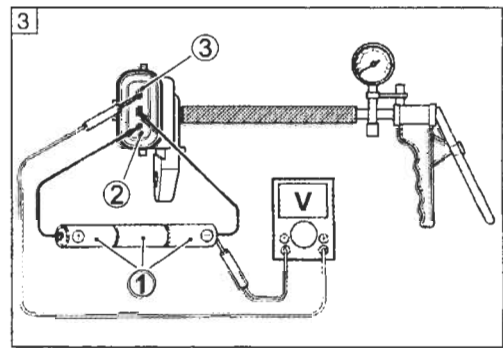

Is the voltage OK?

YES	<ul style="list-style-type: none"> <li>• Red, G/B or B/Br wire open or shorted to ground, or poor ⑩, ⑯ or ⑳ connection.</li> <li>• If wire and connection are OK, intermittent trouble or faulty ECM.</li> <li>• Recheck each terminal and wire harness for open circuit and poor connection.</li> </ul>
NO	If check result is not satisfactory, replace IAP sensor with a new one.

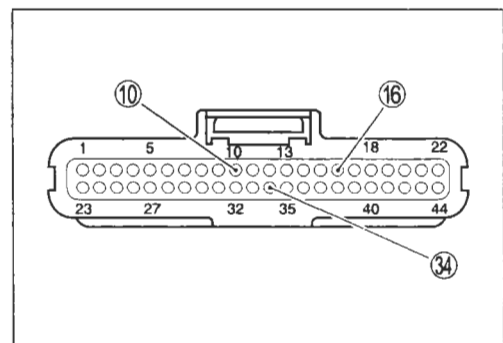

Output voltage (Vcc voltage 4.5 V, ambient temp. 25 °C,  
77 °F)

ALTITUDE (Reference)		ATMOSPHERIC PRESSURE		OUTPUT VOLTAGE
(ft)	(m)	(mmHg)	kPa	(V)
0   2 000	0   610	760   707	100   94	Approx. 3.3 – 3.6
2 001   5 000	611   1 524	707   634	94   85	Approx. 3.0 – 3.3
5 001   8 000	1 525   2 438	634   567	85   76	Approx. 2.7 – 3.0
8 001   10 000	2 439   3 048	567   526	76   70	Approx. 2.5 – 2.7

## “C14” TP SENSOR CIRCUIT MALFUNCTION

DETECTED CONDITION	POSSIBLE CAUSE
Output voltage is out of the specified range. $0.1\text{ V} \leq \text{Sensor voltage} < 4.8\text{ V}$	<ul style="list-style-type: none"> <li>• TP sensor maladjusted.</li> <li>• TP sensor circuit open or short.</li> <li>• TP sensor malfunction.</li> <li>• ECM malfunction.</li> </ul>

### INSPECTION

#### Step 1

- 1) Remove the fuel tank (☞ 5-7).
- 2) Turn the ignition switch OFF.
- 3) Check the TP sensor coupler for loose or poor contacts.  
If OK, then measure the TP sensor input voltage.
- 4) Disconnect the TP sensor coupler.

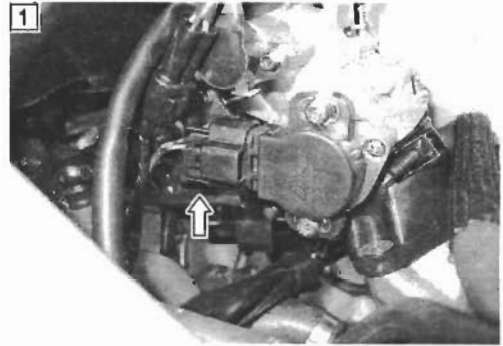

- 5) Turn the ignition switch ON.
- 6) Measure the voltage at the Red wire and ground.
- 7) If OK, then measure the voltage at the Red wire and B/Br wire.

**DATA** TP sensor input voltage: 4.5 – 5.5 V

(⊕ Red – ⊖ Ground)

(⊕ Red – ⊖ B/Br)

**TOOL** 09900-25008: Multi circuit tester set

**Tester knob indication: Voltage (V)**

Is the voltage OK?

YES	Go to Step 2
NO	<ul style="list-style-type: none"> <li>• Loose or poor contacts on the ECM coupler.</li> <li>• Open or short circuit in the Red wire or B/Br wire.</li> </ul>

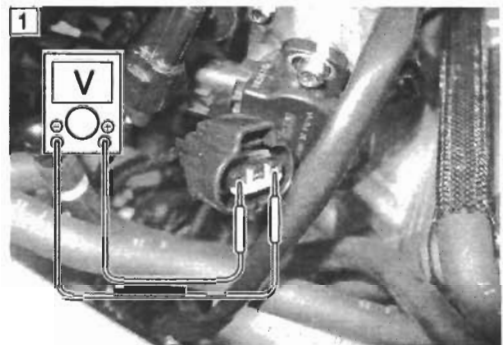
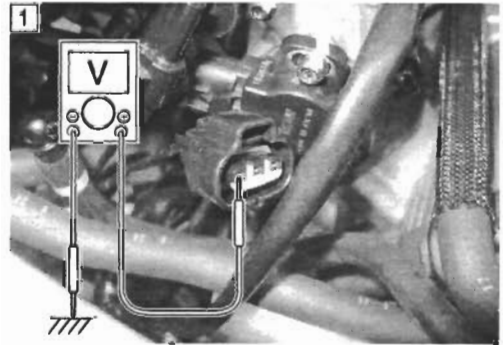

**Step 2**

- 1) Remove the air cleaner box. (☞ 5-15)
- 2) Turn the ignition switch OFF.
- 3) Disconnect the TP sensor coupler.
- 4) Check the continuity between (A) and ground.

**DATA** TP sensor continuity:  $\infty \Omega$  (Infinity)  
(A – Ground)

- 5) If OK, then measure the TP sensor resistance (between (A) and (B)).
- 6) Turn the throttle grip and measure the resistance.

**DATA** TP sensor resistance  
Throttle valve is closed : Approx. 1.12 k $\Omega$   
Throttle valve is opened: Approx. 4.26 k $\Omega$

**TOOL** 09900-25008: Multi circuit tester set

**Tester knob indication: Resistance ( $\Omega$ )**

Are the resistance and continuity OK?

YES	Go to Step 3
NO	<ul style="list-style-type: none"> <li>• Reset the TP sensor position correctly.</li> <li>• Replace the TP sensor with a new one.</li> </ul>

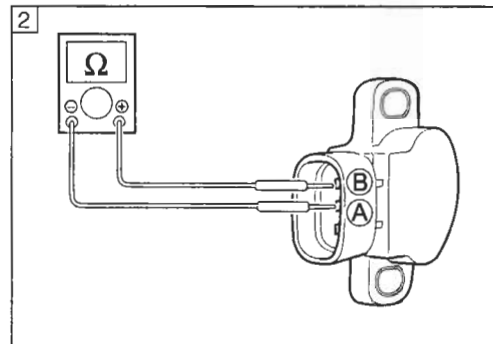
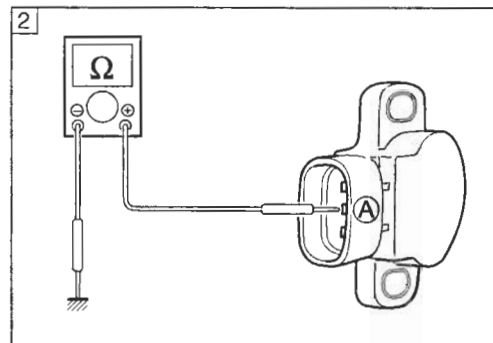

**Step 3**

- 1) Connect the TP sensor coupler.
- 2) Insert the needle pointed probes to the lead wire coupler.
- 3) Turn the ignition switch ON.

Measure the TP sensor output voltage at the coupler (between ⊕ P/W and ⊖ B/Br) by turning the throttle grip.

**DATA** TP sensor output voltage

Throttle valve is closed : Approx. 1.12 V

Throttle valve is opened: Approx. 4.26 V

- TOOL** 09900-25008: Multi circuit tester set  
 09900-25009: Needle pointed probe set

**Tester knob indication: Voltage (V)**

Is the voltage OK?

YES	<ul style="list-style-type: none"> <li>• Red, P/W or B/Br wire open or shorted to ground, or poor ⑩, ⑲ or ⑳ connection.</li> <li>• If wire and connection are OK, intermittent trouble or faulty ECM.</li> <li>• Recheck each terminal and wire harness for open circuit and poor connection.</li> </ul>
NO	If check result is not satisfactory, replace TP sensor with a new one.

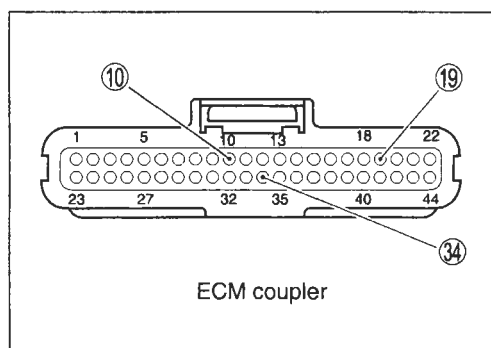
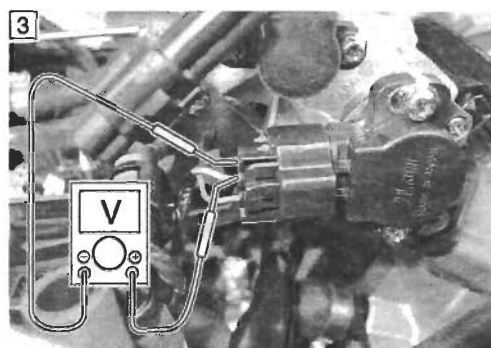

## “C15” ECT SENSOR CIRCUIT MALFUNCTION

DETECTED CONDITION	POSSIBLE CAUSE
Output voltage is out of the specified range. $0.1\text{ V} \leq \text{Sensor voltage} < 4.6\text{ V}$	<ul style="list-style-type: none"> <li>ECT sensor circuit open or short.</li> <li>ECT sensor malfunction.</li> <li>ECM malfunction.</li> </ul>

### INSPECTION

#### Step 1

- 1) Turn the ignition switch OFF.
- 2) Check the ECT sensor coupler for loose or poor contacts.  
If OK, then measure the ECT sensor voltage at the wire side coupler.
- 3) Disconnect the coupler and turn the ignition switch ON.

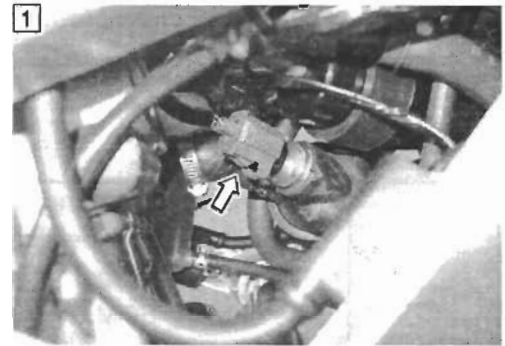

- 4) Measure the voltage between B/BI wire terminal ① and ground.
- 5) If OK, then measure the voltage between B/BI wire terminal ① and B/Br wire terminal ②.

**DATA** ETC sensor voltage: 4.5 – 5.5 V  
 (+ B/BI – – Ground)  
 (+ B/BI – – B/Br)

**TOOL** 09900-25008: Multi circuit tester set

**Tester knob indication: Voltage (V)**

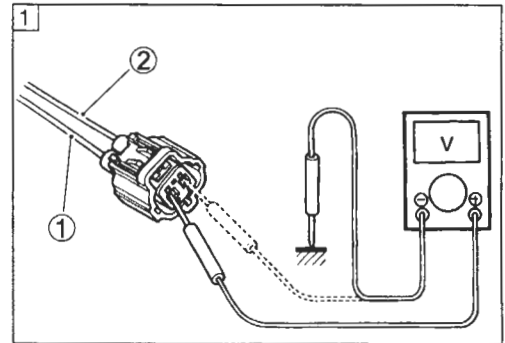

Is the voltage OK?

YES	Go to Step 2
NO	<ul style="list-style-type: none"> <li>Loose or poor contacts on the ECM coupler.</li> <li>Open or short circuit in the B/BI wire or B/Br wire.</li> </ul>

**Step 2**

- 1) Turn the ignition switch OFF.
- 2) Measure the ECT sensor resistance. (Refer to page 6-10 for details.)

**DATA** ECT sensor resistance:  
 Approx. 2.45 kΩ at 20 °C (68 °F) (Terminal – Terminal)

**TOOL** 09900-25008: Multi circuit tester set

**Tester knob indication: Resistance (Ω)**

Is the resistance OK?

YES	<ul style="list-style-type: none"> <li>• B/Br or B/BI wire open or shorted to ground, or poor ③④ or ③⑥ connection.</li> <li>• If wire and connection are OK, intermittent trouble or faulty ECM.</li> <li>• Recheck each terminal and wire harness for open circuit and poor connection.</li> </ul>
NO	Replace the ECT sensor with a new one.

Engine Coolant Temp	Resistance
20 °C (68 °F)	Approx. 2.45 kΩ
40 °C (104 °F)	Approx. 1.148 kΩ
60 °C (140 °F)	Approx. 0.587 kΩ
80 °C (176 °F)	Approx. 0.322 kΩ

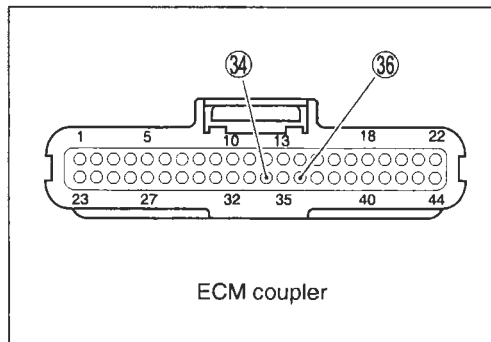
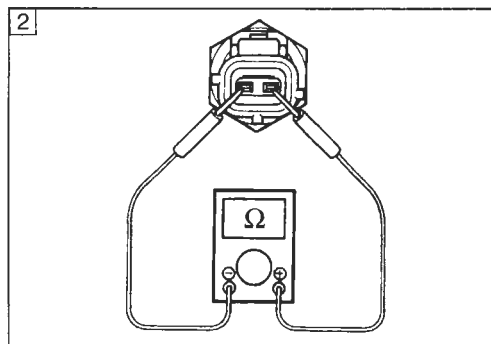



## “C21” IAT SENSOR CIRCUIT MALFUNCTION

DETECTED CONDITION	POSSIBLE CAUSE
Output voltage is out of the specified range. 0.1 V ≤ Sensor voltage < 4.6 V	<ul style="list-style-type: none"> <li>• IAT sensor circuit open or short.</li> <li>• IAT sensor malfunction.</li> <li>• ECM malfunction.</li> </ul>

### INSPECTION

#### Step 1

- 1) Lift and support the fuel tank. (☞ 5-7)
- 2) Turn the ignition switch OFF.
- 3) Check the IAT sensor coupler for loose or poor contacts.  
If OK, then measure the IAT sensor voltage at the wire side coupler.
- 4) Disconnect the coupler and turn the ignition switch ON.
- 5) Measure the voltage between Dg wire terminal ① and ground.
- 6) If OK, then measure the voltage between Dg wire terminal ① and B/Br wire terminal ②.

**DATA** IAT sensor voltage: 4.5 – 5.5 V  
 (+ Dg – ⊖ Ground)  
 (+ Dg – ⊖ B/Br)

**TOOL** 09900-25008: Multi circuit tester set

**Tester knob indication: Voltage (---)**

Is the voltage OK?

YES	Go to Step 2
NO	<ul style="list-style-type: none"> <li>• Loose or poor contacts on the ECM coupler.</li> <li>• Open or short circuit in the Dg wire or B/Br wire.</li> </ul>

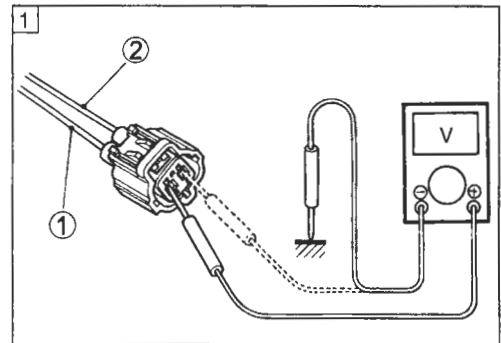

**Step 2**

- 1) Turn the ignition switch OFF.
- 2) Measure the IAT sensor resistance.

**DATA** IAT sensor resistance:  
 Approx. 2.45 kΩ at 20 °C (68 °F) (Terminal – Terminal)

**TOOL** 09900-25008: Multi circuit tester set

**TESTER** Tester knob indication: Resistance (Ω)

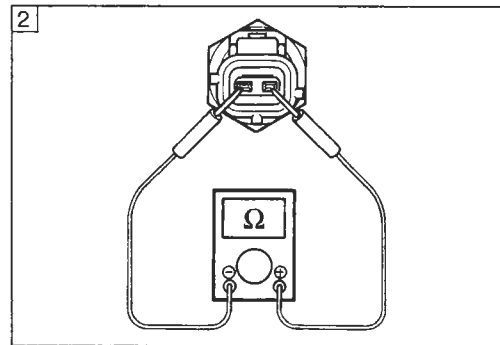

Is the resistance OK?

YES	<ul style="list-style-type: none"> <li>• Dg or B/Br wire open or shorted to ground, or poor ⑭ or ⑳ connection.</li> <li>• If wire and connection are OK, intermittent trouble or faulty ECM.</li> <li>• Recheck each terminal and wire harness for open circuit and poor connection.</li> </ul>
NO	Replace the IAT sensor with a new one.

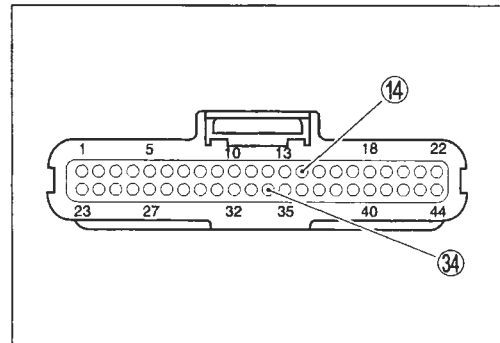

Intake Air Temp	Resistance
20 °C (68 °F)	Approx. 2.45 kΩ
40 °C (104 °F)	Approx. 1.148 kΩ
60 °C (140 °F)	Approx. 0.587 kΩ
80 °C (176 °F)	Approx. 0.322 kΩ

**NOTE:**

IAT sensor resistance measurement method is the same way as that of the ECT sensor. Refer to page 6-10 for details.

## “C23” TO SENSOR CIRCUIT MALFUNCTION

DETECTED CONDITION	POSSIBLE CAUSE
The sensor voltage should be the following for 2 sec. and more after ignition switch turns ON. $0.2\text{ V} \leq \text{Sensor voltage} \leq 4.6\text{ V}$	<ul style="list-style-type: none"> <li>• TO sensor circuit open or short.</li> <li>• TO sensor malfunction.</li> <li>• ECM malfunction.</li> </ul>

### INSPECTION

#### Step 1

- 1) Remove the seat. (7-4)
- 2) Turn the ignition switch OFF.
- 3) Check the TO sensor coupler for loose or poor contacts.  
If OK, then measure the TO sensor resistance.

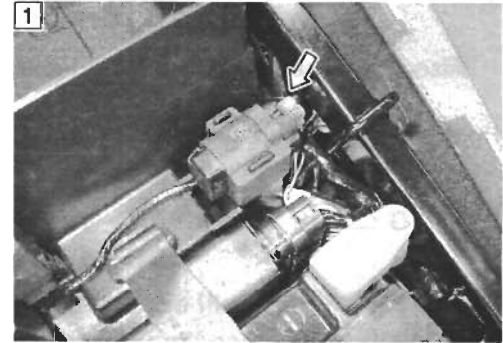

- 4) Remove the TO sensor.
- 5) Measure the resistance between (A) and (B) terminals.

**DATA** TO sensor resistance:

19.1 – 19.7 kΩ (A – B terminals)

**TOOL** 09900-25008: Multi circuit tester set

**Tester knob indication: Resistance (Ω)**

Is the resistance OK?

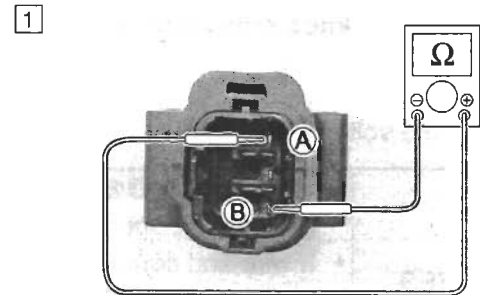

YES	Go to Step 2
NO	Replace the TO sensor with a new one.

**Step 2**

- 1) Connect the TO sensor coupler.
- 2) Insert the needle pointed probe to the lead wire coupler.
- 3) Turn the ignition switch ON.
- 4) Measure the voltage at the wire side coupler between Br/W and B/Br wires of the TO sensor at horizontal.

**DATA** TO sensor voltage: **0.4 – 1.4 V**  
 (+ Br/W – (-) B/Br)

Also, measure the voltage when leaning of the motorcycle.

- 5) Measure the voltage when it is leaned more than 65 °, left and right, from the horizontal level.

**DATA** TO sensor voltage: **3.7 – 4.4 V**  
 (+ Br/W – (-) B/Br)

- TOOL** 09900-25008: Multi circuit tester set  
 09900-25009: Needle pointed probe set

**Tester knob indication: Voltage (V)**

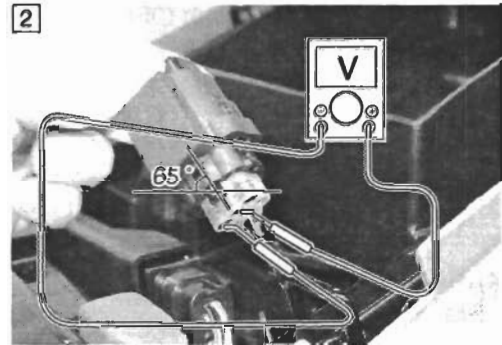
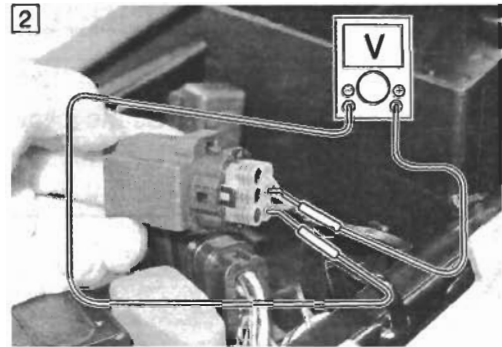

Is the voltage OK?

YES	<ul style="list-style-type: none"> <li>• Red, Br/W or B/Br wire open or shorted to ground, or poor (10), (41) or (34) connection.</li> <li>• If wire and connection are OK, intermittent trouble or faulty ECM.</li> <li>• Recheck each terminal and wire harness for open circuit and poor connection.</li> </ul>
NO	<ul style="list-style-type: none"> <li>• Loose or poor contacts on the ECM coupler.</li> <li>• Open or short circuit in the Br/W wire or B/Br wire.</li> <li>• Replace the TO sensor with a new one.</li> </ul>

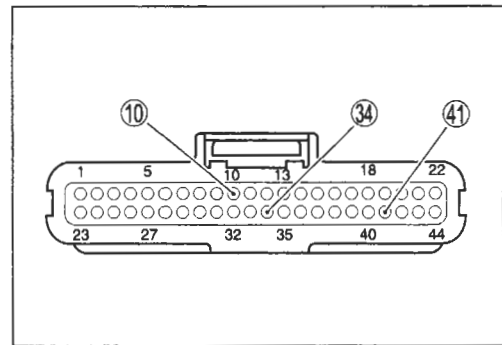

**“C24” or “C25” IGNITION SYSTEM MALFUNCTION**

\*Refer to the IGNITION SYSTEM for details. (➡ 8-23)

## “C28” STV ACTUATOR CIRCUIT MALFUNCTION

DETECTED CONDITION	POSSIBLE CAUSE
The operation voltage does not reach the STVA. ECM does not receive communication signal from the STVA.	<ul style="list-style-type: none"> <li>• STVA malfunction.</li> <li>• STVA circuit open or short.</li> <li>• STVA motor malfunction.</li> </ul>

### INSPECTION

#### Step 1

- 1) Remove the fuel tank and air cleaner box. (☞ 5-15)
- 2) Turn the ignition switch OFF.
- 3) Check the STVA coupler for loose or poor contacts.
- 4) Turn the ignition switch ON to check the STV operation.  
STV operating order: Full open (A) → Open (B)  
(Approx. 1 seconds later)  
Is the operation OK?

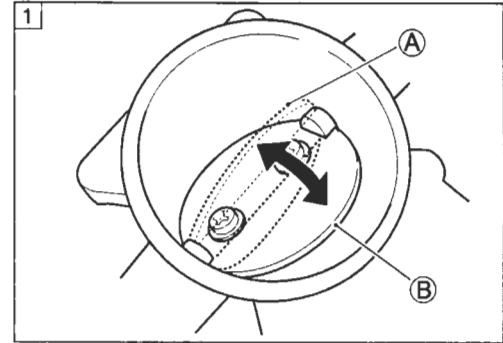

YES	Go to Step 2
NO	<ul style="list-style-type: none"> <li>• Loose or poor contacts on the STVA coupler.</li> <li>• Open or short circuit in the B/R and R/B wires.</li> </ul>

#### Step 2

- 1) Turn the ignition switch OFF.
- 2) Check the STVA coupler for loose or poor contacts.
- 3) Disconnect the STVA coupler.
- 4) Check the continuity between terminal ① and ground.

**DATA** STVA continuity: ∞ Ω (Infinity)

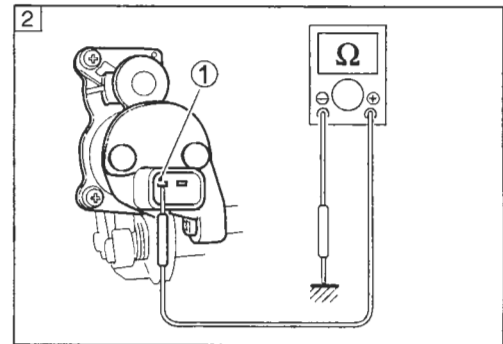

- 5) If OK, then measure the STVA resistance.

**DATA** STVA resistance: Approx. 7 – 14 Ω

**TOOL** 09900-25008: Multi circuit tester set

**Tester knob indication: Resistance (Ω)**

Is the resistance OK?

YES	<ul style="list-style-type: none"> <li>• Loose or poor contacts on the STVA coupler, or poor ⑳ or ㉓ connection.</li> <li>• If wire and connection are OK, intermittent trouble or faulty ECM. Recheck each terminal and wire harness for open circuit and poor connection.</li> </ul>
NO	Replace the STVA with a new one.

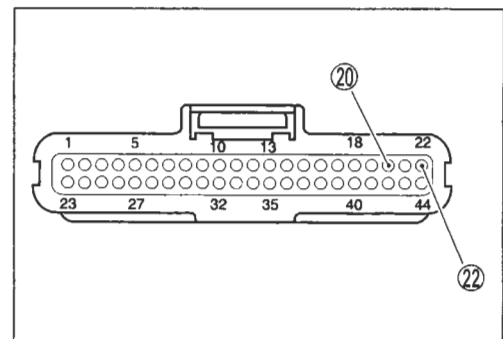
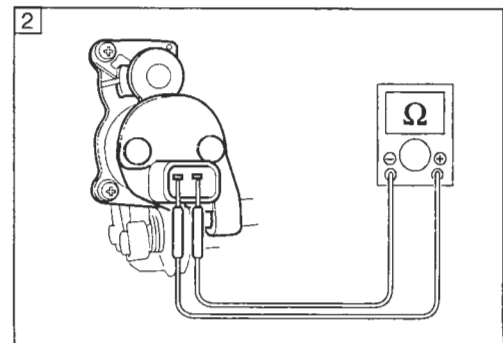

### “C29” STP SENSOR CIRCUIT MALFUNCTION

DETECTED CONDITION	POSSIBLE CAUSE
Signal voltage is out of the specified range. Difference between actual throttle opening and opening calculated by ECM is larger than specified value. $0.1\text{ V} \leq \text{Sensor voltage} \leq 4.8\text{ V}$	<ul style="list-style-type: none"> <li>• STP sensor maladjusted.</li> <li>• STP sensor circuit open or short.</li> <li>• STP sensor malfunction.</li> <li>• ECM malfunction.</li> </ul>

#### INSPECTION

##### Step 1

- 1) Remove the air cleaner box. (☞ 5-15)
- 2) Turn the ignition switch OFF.
- 3) Check the STP sensor coupler for loose or poor contacts.  
If OK, then measure the STP sensor input voltage.



- 4) Disconnect the STP sensor coupler.
- 5) Turn the ignition switch ON.
- 6) Measure the voltage at the Red wire and ground.
- 7) If OK, then measure the voltage at the Red wire and B/Br wire.

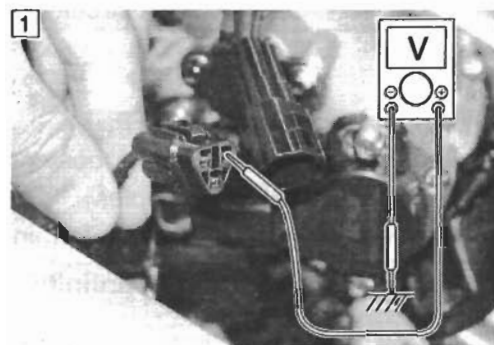

**DATA** STP sensor input voltage: 4.5 – 5.5 V  
 (+ Red – (–) Ground)  
 (+ Red – (–) B/Br)

**TOOL** 09900-25008: Multi circuit tester set

**Tester knob indication: Voltage (V)**



Is the voltage OK?

YES	Go to Step 2
NO	<ul style="list-style-type: none"> <li>• Loose or poor contacts on the ECM coupler.</li> <li>• Open or short circuit in the Red wire or B/Br wire.</li> </ul>

**Step 2**

- 1) Turn the ignition switch OFF.
- 2) Disconnect the STP sensor coupler.
- 3) Check the continuity between Yellow wire and ground.

**DATA** STP sensor continuity:  $\infty \Omega$  (Infinity)  
(Yellow – Ground)

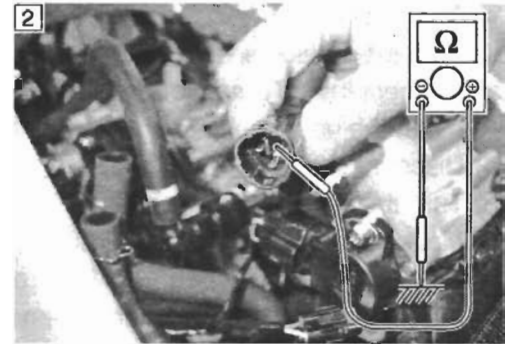

- 4) If OK, then measure the STP sensor resistance at the coupler (between Yellow and Black wires).

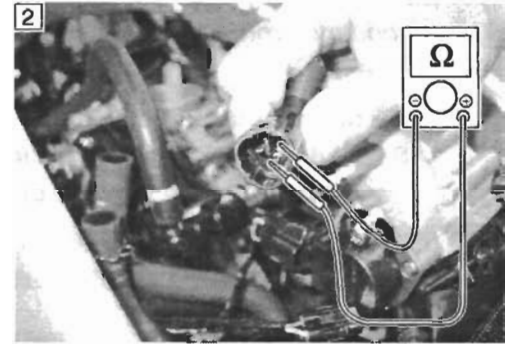

- 5) Close and open the secondary throttle valve fully by turning the actuator shaft end ①, and measure the STP sensor resistance with both STV positions.

**DATA** STP sensor resistance  
 Secondary throttle valve is closed: Approx. 0.58 kΩ  
 Secondary throttle valve is opened: Approx. 4.38 kΩ

**TOOL** 09900-25008: Multi circuit tester set  
**Tester knob indication:** Resistance (Ω)

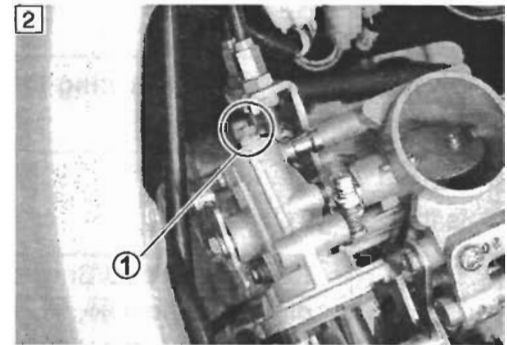

**CAUTION**

Do not use the tool for turning the STVA shaft to prevent breakdown.

Is the resistance OK?

YES	Go to Step 3
NO	<ul style="list-style-type: none"> <li>• Reset the STP sensor position correctly. (5-29)</li> <li>• Replace the STP sensor with a new one.</li> </ul>

**Step 3**

- 1) Turn the ignition switch OFF.
- 2) Connect the STP sensor coupler.
- 3) Insert the needle pointed probes to the STP sensor coupler.
- 4) Disconnect the STVA coupler.
- 5) Turn the ignition switch ON.
- 6) Measure the STP sensor output voltage at the coupler (between ⊕ Yellow and ⊖ B/Br wires) when the secondary throttle valve is full closed and opened.

**NOTE:**

The secondary throttle valve can be turned by rotating the actuator shaft end ①.

**DATA** STP sensor output voltage

Secondary throttle valve is closed: Approx. 0.58 V

Secondary throttle valve is opened: Approx. 4.40 V

- TOOL** 09900-25008: Multi circuit tester set  
 09900-25009: Needle pointed probe set

**Tester knob indication: Voltage (V)**

**CAUTION**

Do not use the tool for turning the STVA shaft to prevent breakdown.

Is the voltage OK?

YES	<ul style="list-style-type: none"> <li>Red, Yellow or B/Br wire open or shorted to ground, or poor ⑩, ④④ or ③④ connection.</li> <li>If wire and connection are OK, intermittent trouble or faulty ECM.</li> <li>Recheck each terminal and wire harness for open circuit and poor connection.</li> </ul>
NO	If check result is not satisfactory, replace STP sensor with a new one.

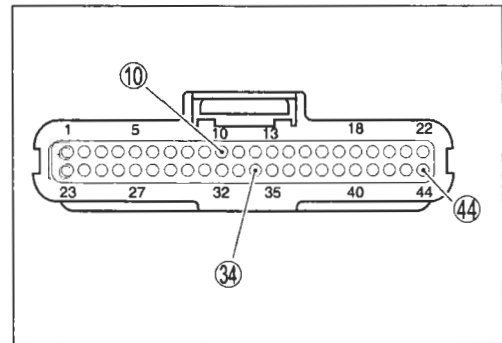
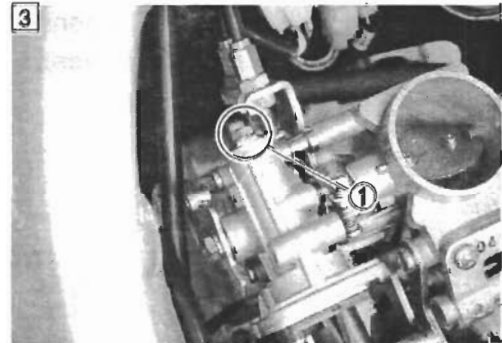
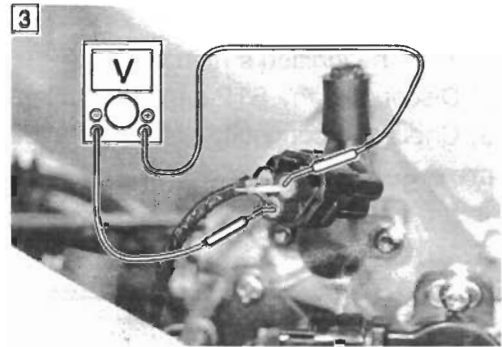



## “C31” GEAR POSITION (GP) SWITCH CIRCUIT MALFUNCTION

DETECTED CONDITION	POSSIBLE CAUSE
No Gear Position switch voltage Switch voltage is out of the specified range. Switch Voltage $\leq 0.2$ V	<ul style="list-style-type: none"> <li>• Gear Position switch circuit open or short.</li> <li>• Gear Position switch malfunction.</li> <li>• ECM malfunction.</li> </ul>

### INSPECTION

#### Step 1

- 1) Remove the left frame cover. (☞ 7-5)
- 2) Turn the ignition switch OFF.
- 3) Check the GP switch coupler for loose or poor contacts.  
If OK, then measure the GP switch voltage.

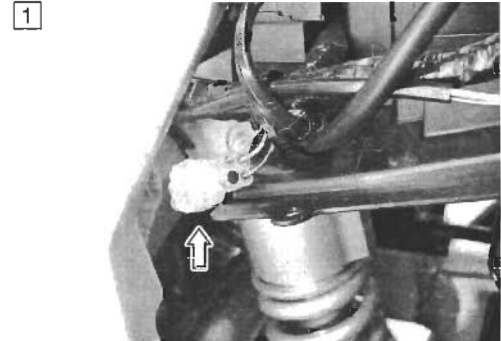

- 4) Support the motorcycle with a jack.
- 5) Turn the side-stand to up-right position.
- 6) Make sure the engine stop switch is in the “RUN” position.
- 7) Insert the needle pointed probes to the GP switch coupler.
- 8) Turn the ignition switch ON.
- 9) Measure the voltage at the wire side coupler between Pink wire and ground, when shifting the gearshift lever from 1st to Top.

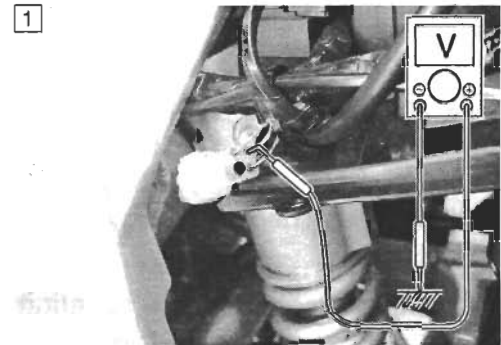

**DATA** GP switch voltage: 1.0 V and more  
(Pink – Ground)

**TOOL** 09900-25008: Multi circuit tester set  
09900-25009: Needle pointed probe set

**Tester knob indication: Voltage (V)**

Is the voltage OK?

YES	<ul style="list-style-type: none"> <li>• Inspect the GP switch voltage. (☞ 8-20)</li> <li>• Pink wire open or shorted to ground, or poor (31) connection.</li> <li>• If wire and connection are OK, intermittent trouble or faulty ECM.</li> <li>• Recheck each terminal and wire harness for open circuit and poor connection.</li> </ul>
NO	Open or short circuit in the Pink wire.

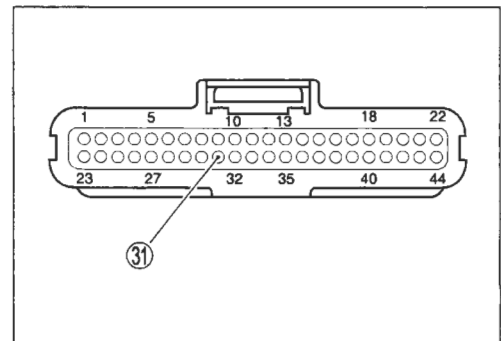

## “C32” or “C33” FUEL INJECTOR CIRCUIT MALFUNCTION

DETECTED CONDITION	POSSIBLE CAUSE
Fuel injector voltage is 1.3 V and less.	<ul style="list-style-type: none"> <li>• Injector circuit open or short.</li> <li>• Injector malfunction.</li> <li>• ECM malfunction.</li> </ul>

### INSPECTION

#### Step 1

- 1) Remove the air cleaner box. (☞ 5-15)
- 2) Turn the ignition switch OFF.
- 3) Check the injector couplers for loose or poor contacts.  
If OK, then measure the injector resistance.

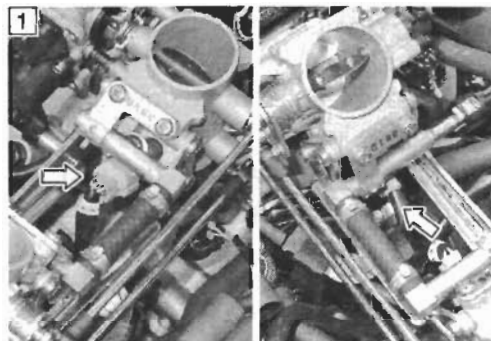

- 4) Disconnect the injector couplers and measure the resistance between terminals.

**DATA** Injector resistance: 11 – 13 Ω at 20 °C (68 °F)

(No.1: ① – ②)

(No.2: ③ – ④)

- 5) If OK, then check the continuity between injector terminals and ground.

**DATA** Injector continuity: ∞ Ω (Infinity)

(No.1: ① – Ground)

(No.2: ③ – Ground)

**TOOL** 09900-25008: Multi circuit tester set

**TESTER** Tester knob indication: Resistance (Ω)

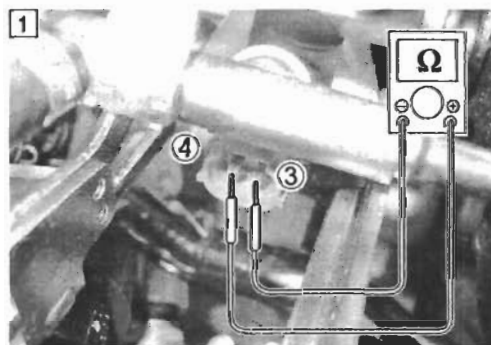
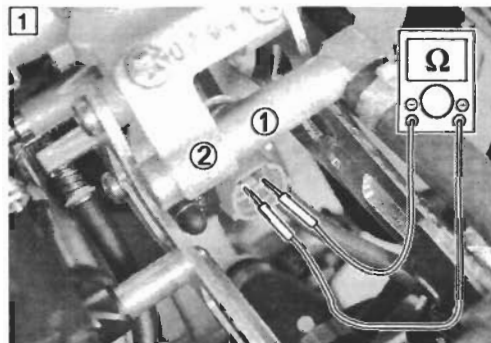

Is the resistance OK?

YES	Go to Step 2
NO	Replace the Injector with a new one. (☞ 5-18)

**Step 2**

- 1) Disconnect the injector couplers.
- 2) Turn the ignition switch ON.
- 3) Measure the injector voltage between Y/R wire (No.1 injector coupler and No.2 injector coupler) and ground.

**DATA** **Injector voltage: Battery voltage**  
 (+ Y/R - - Ground)

**NOTE:**

*Injector voltage can be detected only 2 seconds after ignition switch is turned ON.*

**TOOL** 09900-25008: Multi circuit tester set

**Tester knob indication: Voltage (---)**

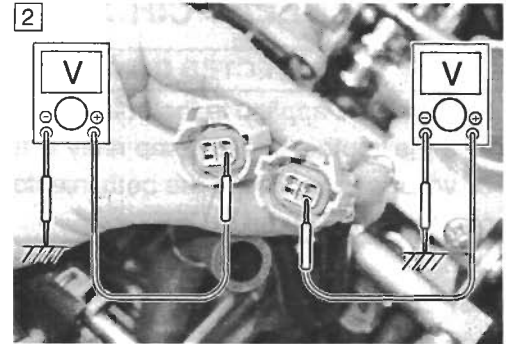

Is the voltage OK?

YES	<ul style="list-style-type: none"> <li>• Gr/W or Gr/B wire open or shorted to ground, or poor ⑤ or ⑥ connection.</li> <li>• If wire and connection are OK, intermittent trouble or faulty ECM.</li> <li>• Recheck each terminal and wire harness for open circuit and poor connection.</li> </ul>
NO	<ul style="list-style-type: none"> <li>• Inspect the fuel pump relay. (↪ 5-10)</li> </ul>

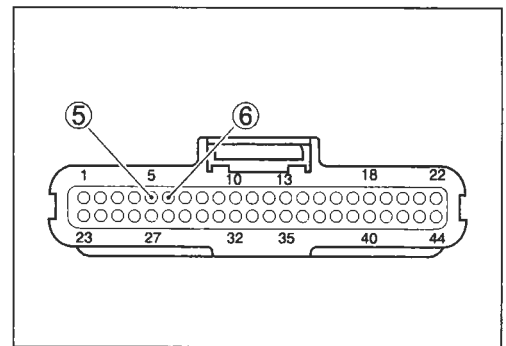

### “C41” FP RELAY CIRCUIT MALFUNCTION

DETECTED CONDITION	POSSIBLE CAUSE
No voltage is applied to the both injectors for 3 sec. after the contact of fuel pump relay is turned ON. Or voltage is applied to the both injectors, when the contact of fuel pump is OFF.	<ul style="list-style-type: none"> <li>Fuel pump relay circuit open or short.</li> <li>Fuel pump relay malfunction.</li> <li>ECM malfunction.</li> </ul>

**INSPECTION**

**Step 1**

- Remove the seat. (☞ 7-4)
- Turn the ignition switch OFF.
- Check the FP relay coupler for loose or poor contacts.  
If OK, then check the insulation and continuity. Refer to page 5-10 for details.

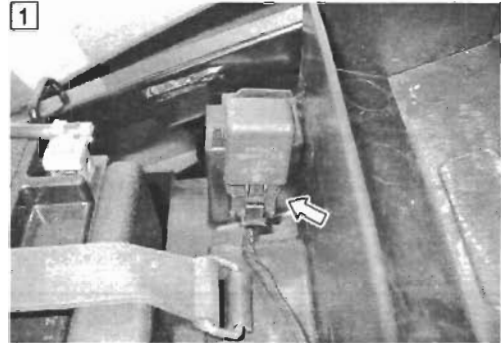

Is the FP relay OK?

YES	<ul style="list-style-type: none"> <li>Y/B or O/G (O/W: For E-03, 24, 28 and 33) wire open or shorted to ground, or poor ③② or ⑨ connection.</li> <li>If wire and connection are OK, intermittent trouble or faulty ECM.</li> <li>Recheck each terminal and wire harness for open circuit and poor connection.</li> <li>Inspect the fuel injectors. (☞ 4-42)</li> </ul>
NO	Replace the FP relay with a new one.

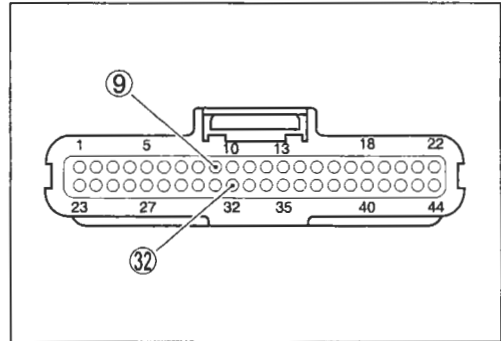

**NOTE:**

When the both fuel injectors break down at a time, “C41” is indicated.

### “C42” IG SWITCH CIRCUIT MALFUNCTION

DETECTED CONDITION	POSSIBLE CAUSE
Ignition switch signal is not input in the ECM.	<ul style="list-style-type: none"> <li>Ignition system circuit open or short.</li> <li>ECM malfunction.</li> </ul>

**INSPECTION**

\*Refer to the IGNITION SWITCH INSPECTION for details. (☞ 8-39)

## “C49” PAIR CONTROL SOLENOID VALVE CIRCUIT MALFUNCTION

DETECTED CONDITION	POSSIBLE CAUSE
PAIR control solenoid valve voltage is not input in ECM.	<ul style="list-style-type: none"> <li>• PAIR control solenoid valve circuit open or short.</li> <li>• PAIR control solenoid valve malfunction.</li> <li>• ECM malfunction.</li> </ul>

### INSPECTION

#### Step 1

- 1) Remove the fuel tank. (☞ 5-7)
- 2) Turn the ignition switch OFF.
- 3) Check the PAIR control solenoid valve coupler for loose or poor contacts.  
If OK, then measure the PAIR control solenoid valve resistance.

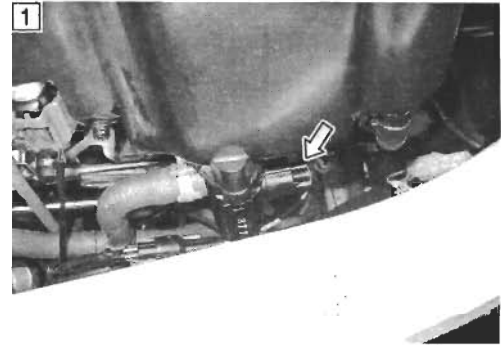

- 4) Remove the air cleaner box. (☞ 5-15)
- 5) Disconnect the PAIR control solenoid valve coupler and measure the resistance between terminals.

**DATA** PAIR control solenoid valve resistance:  
20 – 24 Ω at 20 °C/68 °F

**TOOL** 09900-25008: Multi circuit tester set

**Tester knob indication: Resistance (Ω)**

Is the resistance OK?

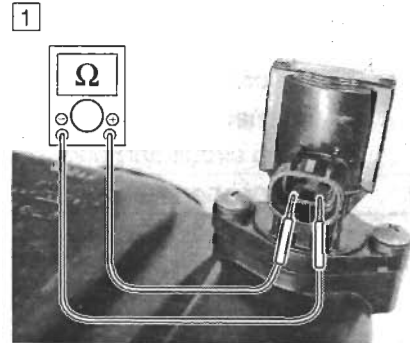

YES	Go to Step 2
NO	<ul style="list-style-type: none"> <li>• Loose or poor contacts on the ECM coupler.</li> <li>• Replace the PAIR control solenoid valve with a new one.</li> </ul>

**Step 2**

- 1) Connect the PAIR control solenoid valve coupler.
- 2) Turn the ignition switch ON.
- 3) Insert the needle pointed probes to the PAIR control solenoid valve coupler.
- 4) Measure the voltage at the wire side coupler between Brown wire and ground.

**DATA** PAIR control solenoid valve voltage: Battery voltage  
(+ Brown - - Ground)

**TOOL** 09900-25008: Multi circuit tester set  
09900-25009: Needle pointed probe set

**TESTER** Tester knob indication: Voltage (V)

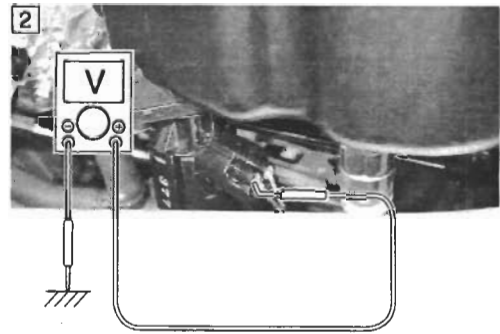

Is the voltage OK?

YES	<ul style="list-style-type: none"> <li>• Brown wire open or shorted to ground, or ⑦ connection.</li> <li>• If wire and connection are OK, intermittent trouble or faulty ECM.</li> <li>• Recheck each terminal and wire harness for open circuit and poor connection.</li> </ul>
NO	Open or short circuit in the Brown wire.

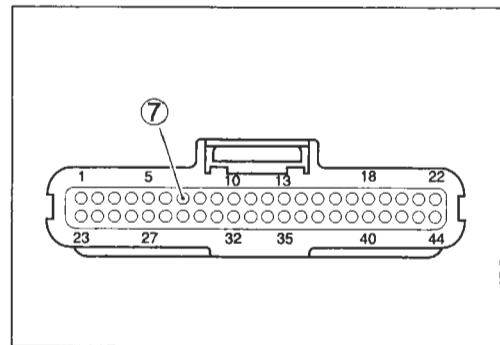

## “C44” HO2 SENSOR (HO2S) CIRCUIT MALFUNCTION (E-02, 19)

DETECTED CONDITION	POSSIBLE CAUSE
The sensor voltage should be the following and less after warming up condition. (Sensor Voltage $\leq 0.4$ V)	<ul style="list-style-type: none"> <li>• HO2 sensor or its circuit open or short.</li> <li>• Fuel system malfunction.</li> <li>• ECM malfunction.</li> </ul>

### INSPECTION

#### Step 1

- 1) Lift and support the fuel tank. (☞ 5-7)
- 2) Turn the ignition switch OFF.
- 3) Check the HO2 sensor coupler for loose or poor contacts.

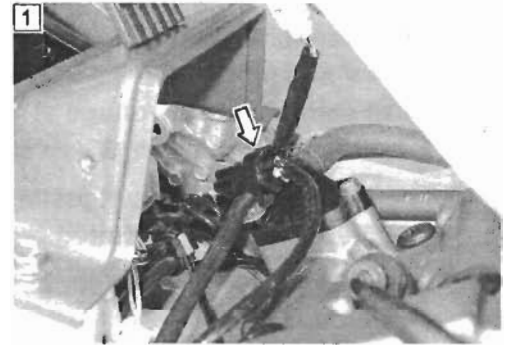

- 4) Insert the needle pointed probes to the HO2 sensor coupler.
- 5) Turn the ignition switch ON and measure the heater voltage between O/W wire (ECM side) and ground.
- 6) If the tester voltage indicates the battery voltage for few seconds, it is good condition.

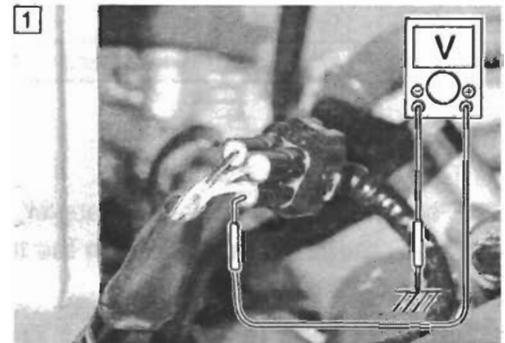

**DATA** Heater voltage: Battery voltage (O/W – Ground)

#### NOTE:

Battery voltage can be detected only during few seconds after ignition switch is turned ON.

- TOOL** 09900-25008: Multi circuit tester set
- 09900-25009: Needle pointed probe set

**TESTER** Tester knob indication: Voltage (---)

Is the voltage OK?

YES	Go to Step 2
NO	Replace the HO2 sensor with a new one.

**Step 2**

- 1) Warm up the engine enough.
- 2) Insert the needle pointed probes to the HO2 sensor coupler.
- 3) Measure the HO2 sensor output voltage at the coupler (between W/G and B/Br wires) when idling condition.
- 4) Also, measure the HO2 sensor output voltage while holding the engine speed at 5 000 r/min.

**DATA** HO2 sensor output voltage at idle speed:  
 0.4 V and less (+ W/G – - B/Br)  
 HO2 sensor output voltage at 5 000 r/min:  
 0.6 V and more (+ W/G – - B/Br)

**TOOL** 09900-25008: Multi circuit tester set  
 09900-25009: Needle pointed probe set

**Tester knob indication: Voltage (V)**

Is the voltage OK?

YES	Go to Step 3
NO	Replace the HO2 sensor with a new one.

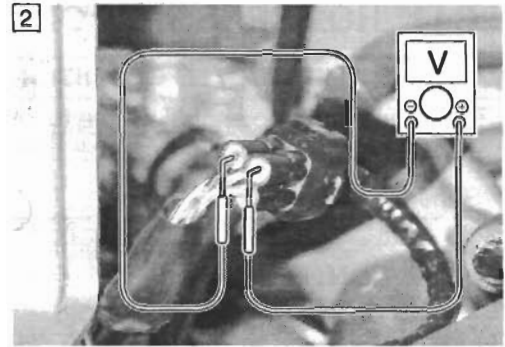

**Step 3**

- 1) Turn the ignition switch OFF.
- 2) Disconnect the HO2 sensor coupler.
- 3) Check the resistance between the terminals (White – White) of the HO2 sensor.

**DATA** HO2 heater resistance: 4 – 5 Ω (at 23 °C/73.4 °F)  
 (White – White)

**NOTE:**

- \* Temperature of the sensor affects resistance value largely.
- \* Make sure that the sensor heater is at correct temperature.

**TOOL** 09900-25008: Multi circuit tester set

**Tester knob indication: Resistance (Ω)**

Is the resistance OK?

YES	<ul style="list-style-type: none"> <li>• W/B, O/G, W/G or B/Br wire open or shorted to ground, or poor ⑧, ⑨, ⑳ or ㉔ connection.</li> <li>• If wire and connection are OK, intermittent trouble or faulty ECM.</li> <li>• Recheck each terminal and wire harness for open circuit and poor connection.</li> </ul>
NO	Replace the HO2 sensor with a new one.

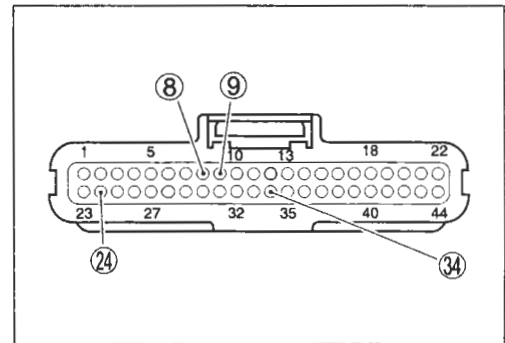
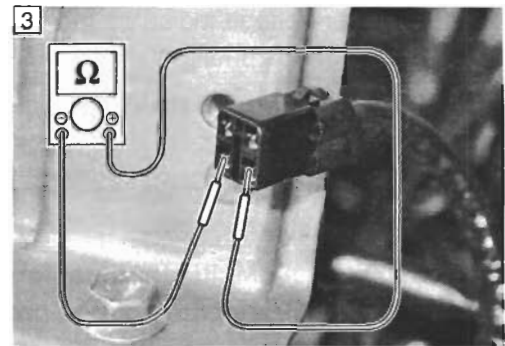



## SENSORS

### CKP SENSOR INSPECTION

The crankshaft position sensor is installed in the generator cover. (☞ 4-23)

### CKP SENSOR REMOVAL AND INSTALLATION

- Remove the generator cover. (☞ 3-26)
- Install the generator cover in the reverse order of removal.

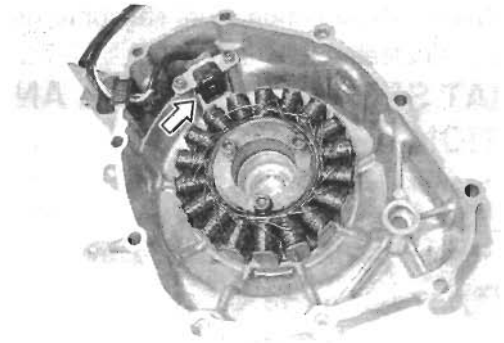

### IAP SENSOR INSPECTION

The intake air pressure sensor is installed at the rear side of the air cleaner box. (☞ 4-25)

### IAP SENSOR REMOVAL AND INSTALLATION

- Lift and support the fuel tank. (☞ 5-7)
- Remove the IAP sensor from the air cleaner box.
- Install the IAP sensor in the reverse order of removal.



### TP SENSOR INSPECTION

The throttle position sensor is installed at the left side of the No.2 throttle body. (☞ 4-28)

### TP SENSOR REMOVAL AND INSTALLATION

- Remove the air cleaner box. (☞ 5-15)
- Remove the TP sensor. (☞ 5-19)
- Install the TP sensor in the reverse order of removal.

 TP sensor mounting screw: 3.5 N·m (0.35 kgf·m, 2.5 lb·ft)

### TPS ADJUSTMENT

- Adjust the TP sensor. (☞ 4-16)

### ECT SENSOR INSPECTION

The ECT sensor is installed on the thermostat case. (☞ 4-31)

### ECT SENSOR REMOVAL AND INSTALLATION

- Remove the ECT sensor. (☞ 6-10)
- Install the ECT sensor in the reverse order of removal.

 ECT sensor: 19 N·m (1.9 kgf·m, 13.5 lb·ft)

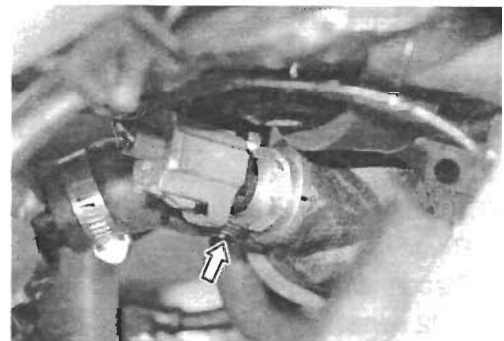
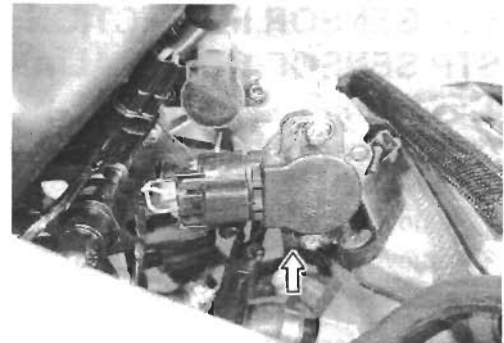

## IAT SENSOR INSPECTION

The intake air temperature sensor is installed on the right side of the air cleaner box. (☞ 4-33)

## IAT SENSOR REMOVAL AND INSTALLATION

- Lift and support the fuel tank. (☞ 5-7)
- Remove the IAT sensor from the air cleaner box.
- Install the IAT sensor in the reverse order of removal.

**🔩 IAT sensor: 18 N·m (1.8 kgf·m, 13.0 lb-ft)**

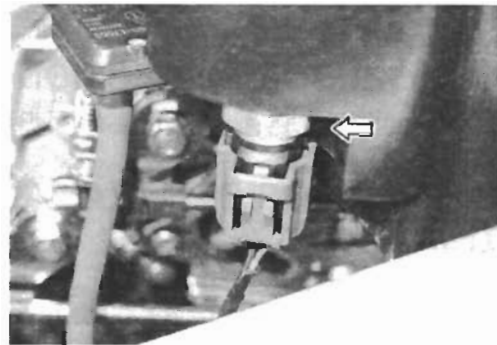

## TO SENSOR INSPECTION

## TO SENSOR REMOVAL AND INSTALLATION

The tip over sensor is located in under the seat. (☞ 4-35)

- Remove the right frame cover. (☞ 7-5)
- Remove the TO sensor from the rear fender.
- Install the TO sensor in the reverse order of removal.

### NOTE:

When installing the TO sensor, the "UP" mark **A** must be pointed upward.

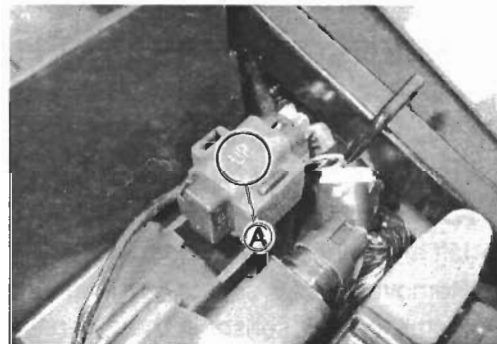

## STP SENSOR INSPECTION

## STP SENSOR REMOVAL AND INSTALLATION

The secondary throttle position sensor is installed at the left side of the No.2 throttle body.

- Remove the air cleaner box. (☞ 5-15)
- Remove the STP sensor. (☞ 5-19)
- Install the STP sensor in the reverse order of removal.

**🔩 STP sensor mounting screw: 2.0 N·m (0.2 kgf·m, 1.5 lb-ft)**

## STP SENSOR ADJUSTMENT

- Adjust the STP sensor. (☞ 5-28)



## HO2 SENSOR INSPECTION (E-02, 19)

## HO2 SENSOR REMOVAL AND INSTALLATION

The HO2 sensor is installed at the exhaust pipe.

- Remove the seat. (☞ 7-4)
- Disconnect the HO2 sensor lead wire coupler and remove the HO2 sensor.
- Install the HO2 sensor in the reverse order of removal.

**🔩 HO2 sensor: 47.5 N·m (4.75 kgf·m, 34.3 lb-ft)**



# FUEL SYSTEM AND THROTTLE BODY

## CONTENTS

<b>FUEL SYSTEM .....</b>	<b>5- 2</b>
<b>FUEL DELIVERY SYSTEM.....</b>	<b>5- 2</b>
<b>FUEL PUMP .....</b>	<b>5- 3</b>
<b>FUEL PRESSURE REGULATOR.....</b>	<b>5- 5</b>
<b>FUEL INJECTOR .....</b>	<b>5- 5</b>
<b>FUEL PUMP CONTROL SYSTEM.....</b>	<b>5- 6</b>
<b>FUEL SYSTEM .....</b>	<b>5- 7</b>
<b>FUEL TANK LIFT-UP.....</b>	<b>5- 7</b>
<b>FUEL TANK REMOVAL.....</b>	<b>5- 7</b>
<b>FUEL TANK INSTALLATION .....</b>	<b>5- 7</b>
<b>FUEL PRESSURE INSPECTION.....</b>	<b>5- 8</b>
<b>FUEL PUMP INSPECTION .....</b>	<b>5- 9</b>
<b>FUEL PUMP RELAY INSPECTION.....</b>	<b>5-10</b>
<b>FUEL PUMP AND FUEL FILTER REMOVAL .....</b>	<b>5-10</b>
<b>FUEL MESH FILTER INSPECTION AND CLEANING .....</b>	<b>5-12</b>
<b>FUEL PUMP AND FUEL MESH FILTER INSTALLATION.....</b>	<b>5-12</b>
<b>THROTTLE BODY AND STV ACTUATOR.....</b>	<b>5-14</b>
<b>CONSTRUCTION.....</b>	<b>5-14</b>
<b>AIR CLEANER AND THROTTLE BODY REMOVAL .....</b>	<b>5-15</b>
<b>THROTTLE BODY DISASSEMBLY .....</b>	<b>5-18</b>
<b>THROTTLE BODY CLEANING.....</b>	<b>5-22</b>
<b>THROTTLE BODY INSPECTION .....</b>	<b>5-22</b>
<b>THROTTLE BODY REASSEMBLY .....</b>	<b>5-23</b>
<b>STV SYNCHRONIZATION.....</b>	<b>5-27</b>
<b>THROTTLE BODY INSTALLATION.....</b>	<b>5-27</b>
<b>STP SENSOR ADJUSTMENT .....</b>	<b>5-28</b>
<b>AIR CLEANER BOX INSTALLATION .....</b>	<b>5-28</b>
<b>TP SENSOR ADJUSTMENT.....</b>	<b>5-29</b>
<b>FAST IDLE INSPECTION .....</b>	<b>5-30</b>
<b>FAST IDLE ADJUSTMENT.....</b>	<b>5-31</b>
<b>THROTTLE VALVE SYNCHRONIZATION.....</b>	<b>5-32</b>

## FUEL SYSTEM

### FUEL DELIVERY SYSTEM

The fuel delivery system consists of the fuel tank, fuel pump, fuel filters, fuel feed hose, fuel delivery pipe (including fuel injectors) and fuel pressure regulator. There is no fuel return hose. The fuel in the fuel tank is pumped up by the fuel pump and pressurized fuel flows into the injector installed in the fuel delivery pipe. Fuel pressure is regulated by the fuel pressure regulator. As the fuel pressure applied to the fuel injector (the fuel pressure in the fuel delivery pipe) is always kept at absolute fuel pressure of 300 kPa (3.0 kgf/cm<sup>2</sup>, 43 psi), the fuel is injected into the throttle body in conic dispersion when the injector opens according to the injection signal from the ECM.

The fuel relieved by the fuel pressure regulator flows back to the fuel tank.

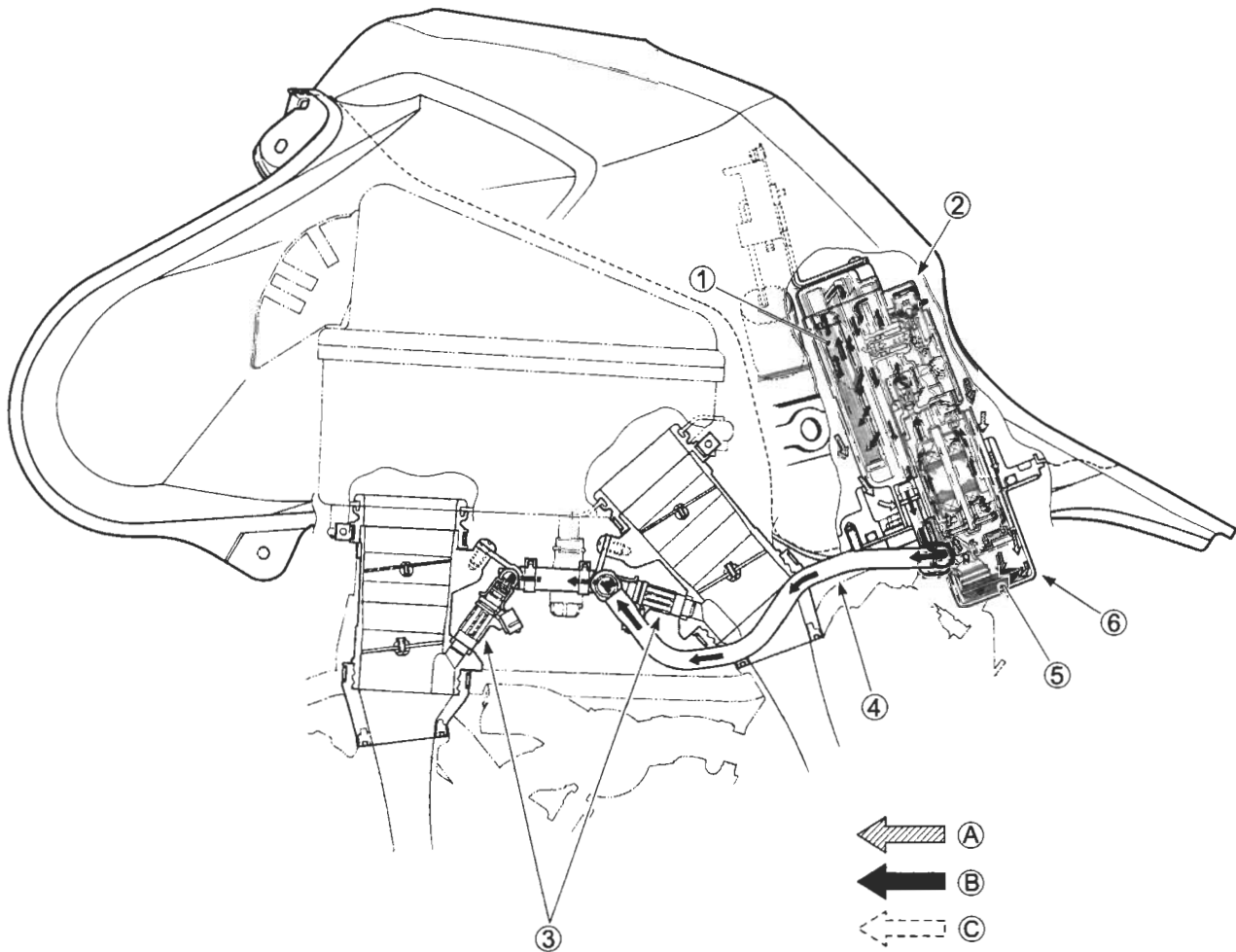

① Fuel filter (For high pressure)	Ⓐ BEFORE-PRESSURIZED FUEL
② Fuel pressure regulator	Ⓑ PRESSURIZED FUEL
③ Fuel injector	Ⓒ RELIEVED FUEL
④ Fuel feed hose	
⑤ Fuel mesh filter (For low pressure)	
⑥ Fuel pump	

## FUEL PUMP

The electric fuel pump is mounted at the bottom of the fuel tank, which consists of the armature, magnet, impeller, brush, check valve and relief valve. The ECM controls its ON/OFF operation as controlled under the FUEL PUMP CONTROL SYSTEM.

When electrical energy is supplied to the fuel pump, the motor in the pump runs and together with the impeller. This causes a pressure difference to occur on both sides of the impeller as there are many grooves around it. Then the fuel is drawn through the inlet port, and with its pressure increased, it is discharged through the outlet port. The fuel pump has a check valve to keep some pressure in the fuel feed hose even when the fuel pump is stopped. Also, the relief valve is equipped in the fuel pump, which releases pressurized fuel to the fuel tank when the outlet of the fuel pressure has increased up to 450 – 600 kPa (4.5 – 6.0 kgf/cm<sup>2</sup>, 64 – 85 psi).

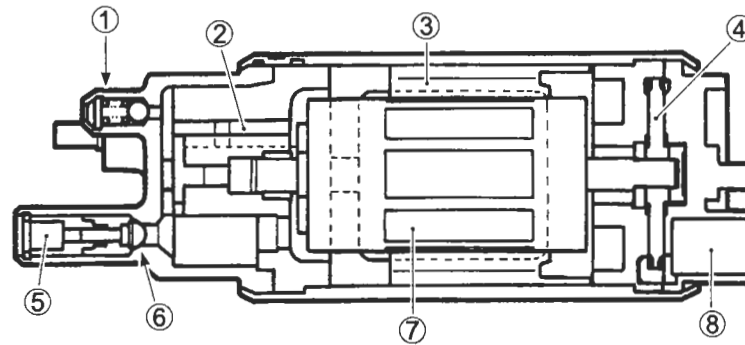

① Relief valve	⑤ Outlet port
② Brush	⑥ Check valve
③ Magnet	⑦ Armature
④ Impeller	⑧ Inlet port

When the impeller is driven by the motor, pressure differential occurs between the front part and the rear part of the blade groove as viewed in angular direction due to fluid friction. This process continuously takes place causing fuel pressure to be built up. The pressurized fuel is then let out from the pump chamber and discharged through the motor section and the check valve.

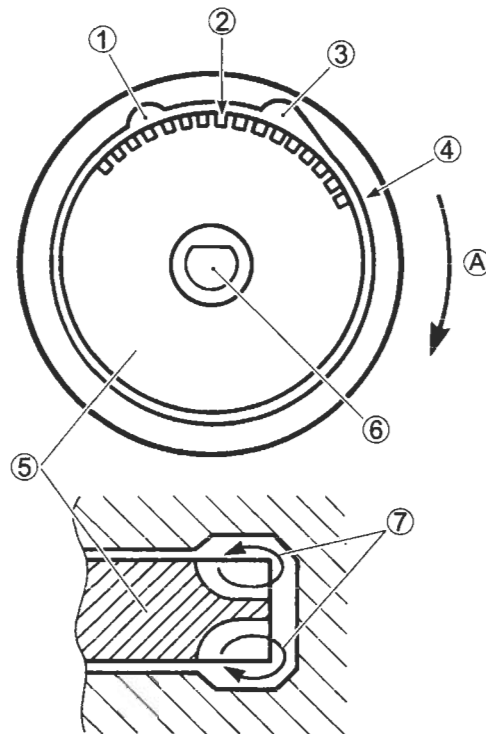

①	Outlet	⑤	Impeller
②	Blade groove	⑥	Motor shaft
③	Inlet	⑦	Vortex flow
④	Flow clearance	Ⓐ	Turning direction

## FUEL PRESSURE REGULATOR

The fuel pressure regulator consists of the spring and valve. It keeps absolute fuel pressure of 300 kPa (3.0 kgf/cm<sup>2</sup>, 43 psi) to be applied to the injector at all times.

When the fuel pressure rises more than 300 kPa (3.0 kgf/cm<sup>2</sup>, 43 psi), the fuel pushes the valve in the regulator open and excess fuel returns to the fuel tank.

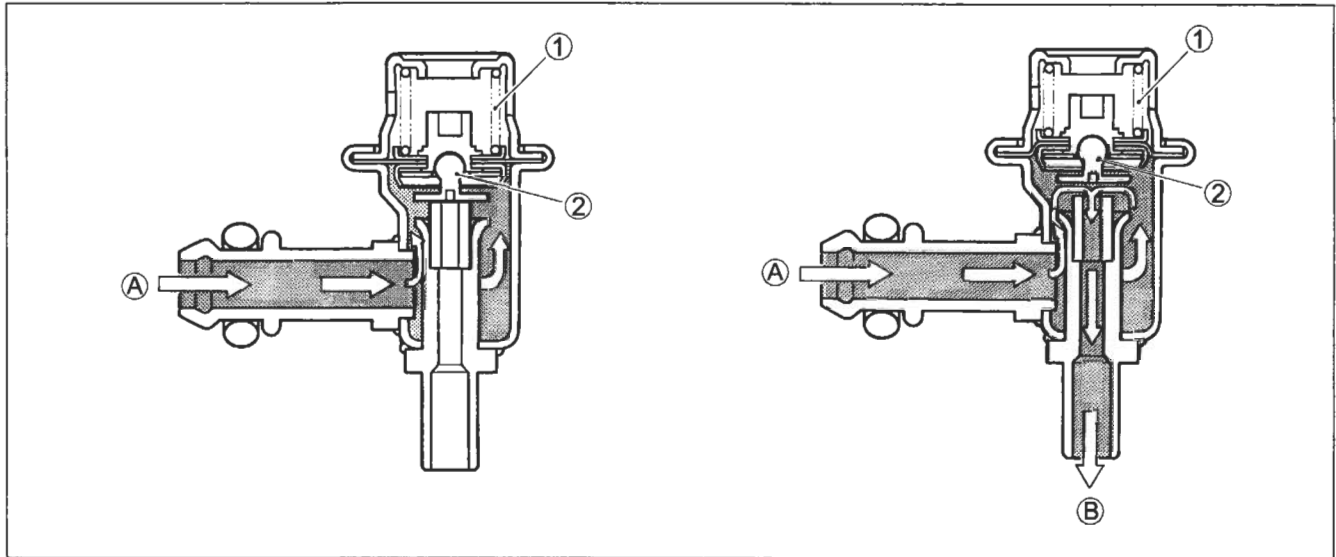

① Spring      ② Valve      A Fuel from fuel pump      B Fuel returns to the fuel tank

## FUEL INJECTOR

The fuel injector consists of the solenoid coil, plunger, needle valve and filter.

It is an electromagnetic type injection nozzle which injects fuel in the throttle body according to the signal from the ECM.

When the solenoid coil of the injector is energized by the ECM, it becomes an electromagnet and attracts the plunger. At the same time, the needle valve incorporated with the plunger opens and the injector which is under the fuel pressure injects fuel in conic dispersion. As the lift stroke of the needle valve of the injector is set constant, the volume of the fuel injected at one time is determined by the length of time during which the solenoid coil is energized (injection time).

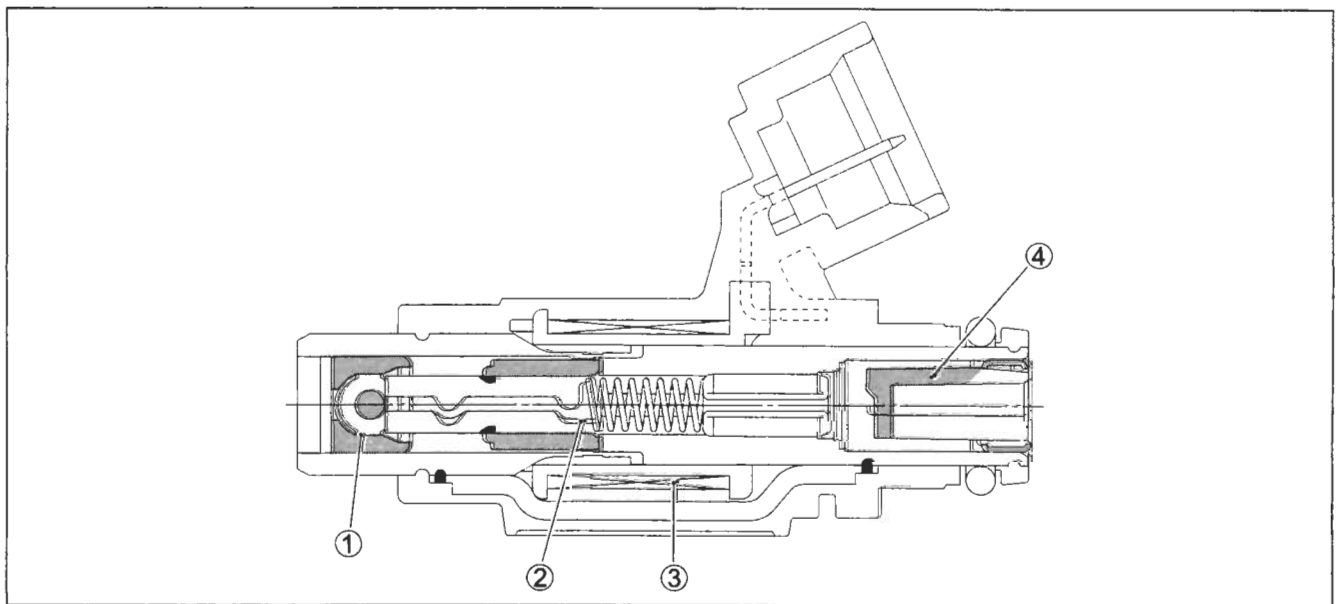

① Needle valve      ② Plunger      ③ solenoid coil      ④ Filter

## FUEL PUMP CONTROL SYSTEM

When the ignition switch is turned on, current from the battery flows to the fuel pump motor through the side-stand relay and the fuel pump relay causing the motor to turn.

Since the ECM has a timer function, the fuel pump motor stops turning in three seconds after the switch has been turned on.

Thereafter, when the crankshaft is turned by the starter motor or the engine has been started, the engine revolving signal is input to the ECM. Then, current flows to the fuel pump motor from the battery through the side-stand relay and the fuel pump relay so that the pump continues to function.

A tip over sensor is provided in the fuel pump control circuit. By this provision, anytime the motorcycle tips over, the tip over sensor sends a signal to the ECM to turn off power to the fuel pump relay, causing the fuel pump motor to stop. At the same time, current to the fuel injectors as well as the ignition coil is interrupted, which then stops the engine.

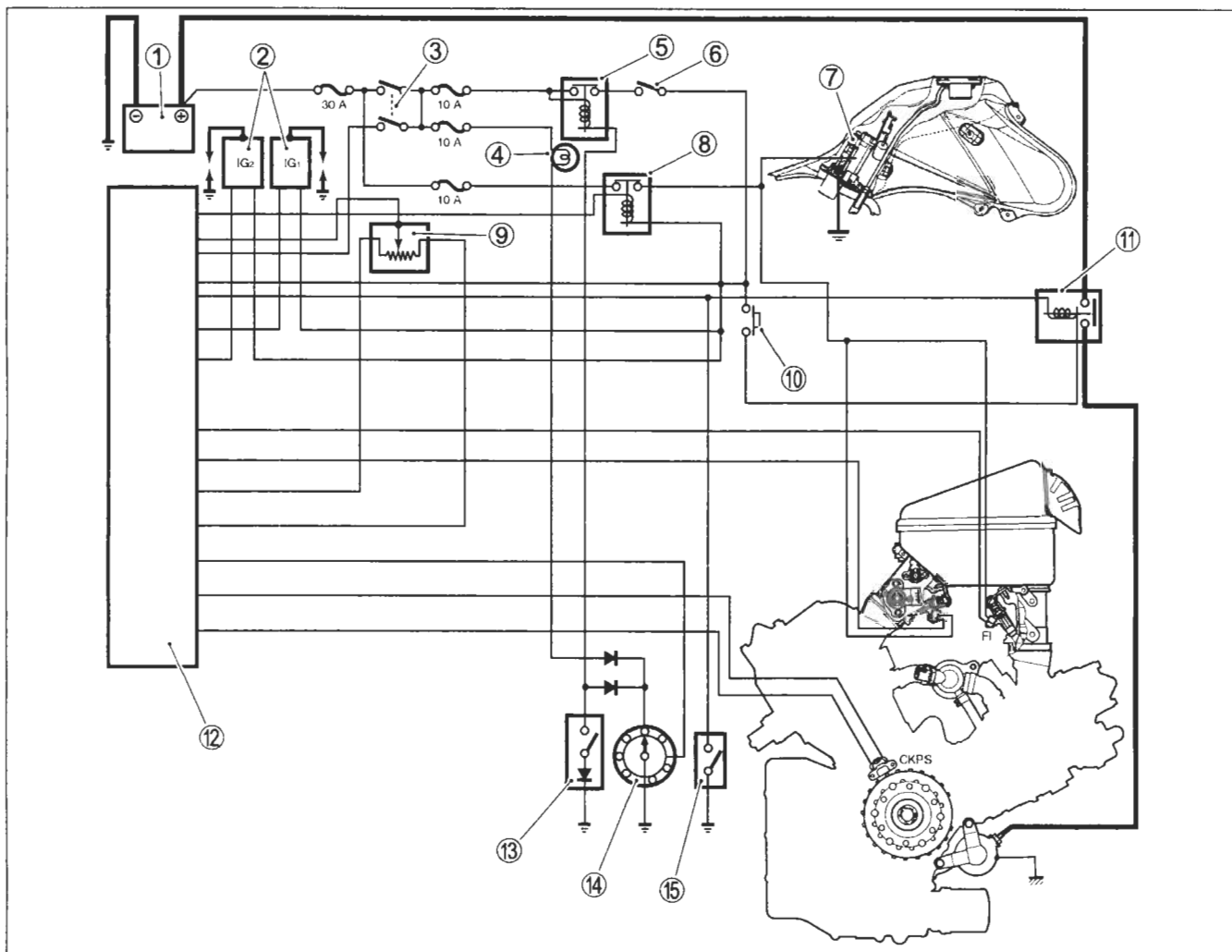

① Battery	⑨ Tip over sensor
② Ignition coil	⑩ Starter button
③ Main switch	⑪ Starter relay
④ Neutral lamp	⑫ ECM
⑤ Side-stand relay	⑬ Side-stand switch
⑥ Engine stop switch	⑭ Gear position switch
⑦ Fuel pump	⑮ Clutch switch
⑧ Fuel pump relay	



## FUEL SYSTEM

### FUEL TANK LIFT-UP

- Remove the seat. (☞7-4)
- Remove the coving. (☞7-5)
- Remove the fuel tank mounting bolt and fuel tank mount stay ①.

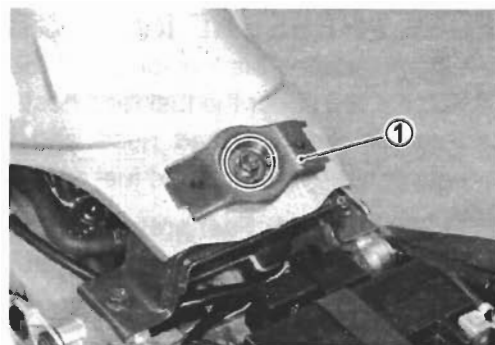

- Lift and support the fuel tank with the fuel tank mount stay.



### FUEL TANK REMOVAL

- Lift and support the fuel tank. (☞5-7)
- Disconnect the fuel pump lead wire coupler ①.
- Place a rag under the fuel feed hose and disconnect the fuel feed hose ② from the fuel tank.
- Disconnect the fuel tank drain hose ③.

#### CAUTION

When removing the fuel tank, do not leave the fuel feed hose ② on the fuel tank side.

#### ⚠ WARNING

Gasoline is highly flammable and explosive.  
Keep heat, spark and flame away.

- Remove the fuel tank mounting bolt and nut.
- Remove the fuel tank.

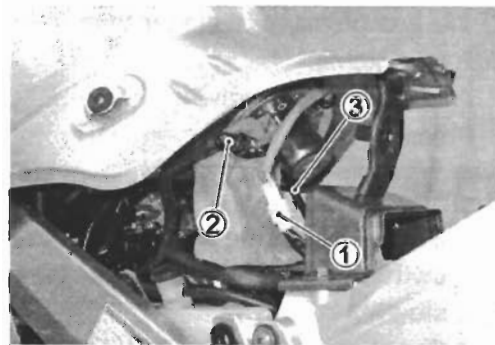

### FUEL TANK INSTALLATION

- Installation is in the reverse order of removal.

## FUEL PRESSURE INSPECTION

- Lift and support the fuel tank. (☞ 5-7)
- Place a rag under the fuel feed hose.
- Remove the fuel feed hose and install the special tools between the fuel tank and fuel delivery pipe.

**TOOL** 09940-40211: Fuel pressure gauge adaptor  
 09940-40220: Fuel pressure gauge hose attachment  
 09915-74511: Oil pressure gauge set

Turn the ignition switch ON and check the fuel pressure.

**DATA** Fuel pressure: Approx. 300 kPa (3.0 kgf/cm<sup>2</sup>, 43 psi)

If the fuel pressure is lower than the specification, inspect the following items:

- \* Fuel hose leakage
- \* Clogged fuel filter
- \* Pressure regulator
- \* Fuel pump

If the fuel pressure is higher than the specification, inspect the following items:

- \* Fuel pump check valve
- \* Pressure regulator

### **⚠ WARNING**

- \* Before removing the special tools, turn the ignition switch to OFF position and release the fuel pressure slowly.
- \* Gasoline is highly flammable and explosive. Keep heat, sparks and flame away.

Ⓐ To fuel delivery pipe.    Ⓑ To fuel feed hose.

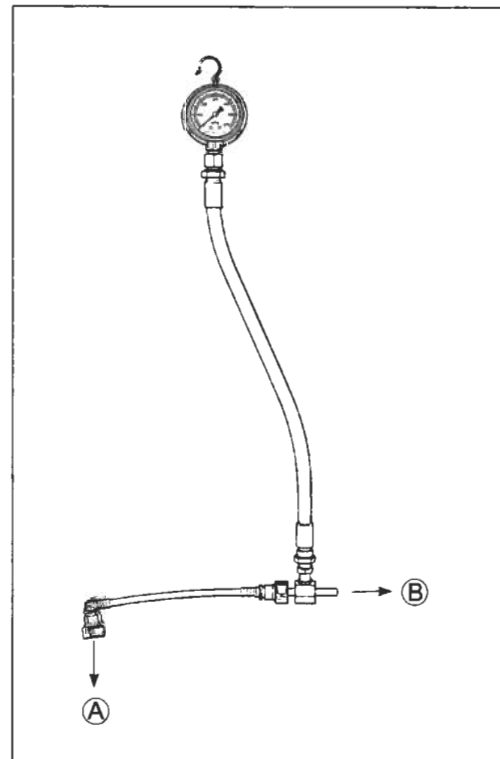
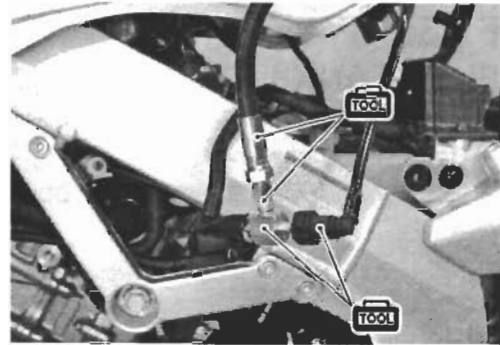

## FUEL PUMP INSPECTION

Turn the ignition switch ON and check that the fuel pump operates for few seconds.

If the fuel pump motor does not make operating sound, replace the fuel pump assembly or inspect the fuel pump relay and tip over sensor.

## FUEL DISCHARGE AMOUNT INSPECTION

### ⚠ WARNING

**Gasoline is highly flammable and explosive.  
Keep heat, spark and flame away.**

- Lift and support the fuel tank. (☞ 5-7)
- Disconnect the fuel feed hose from the fuel tank.
- Connect a proper fuel hose to the fuel pump.
- Place the measuring cylinder and insert the fuel hose end into the measuring cylinder.
- Disconnect the ECM lead wire coupler from the ECM.
- Push the lock (A) to pull out the power source lead wire (Yellow with black tracer (32)).
- Connect the ECM to the ECM lead wire coupler.

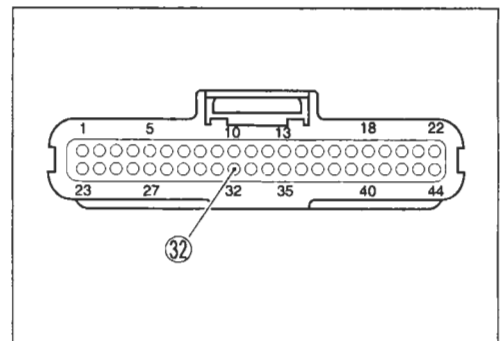
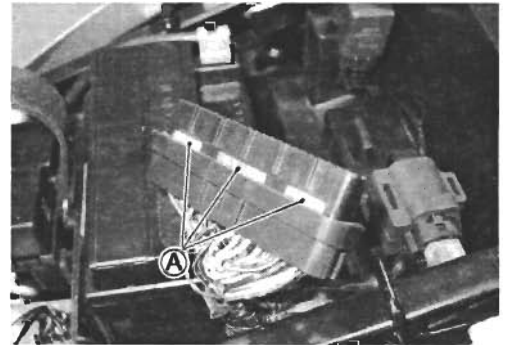
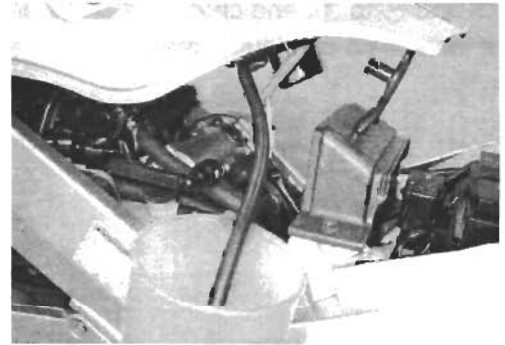

- Apply 12 volts to the fuel pump for 10 seconds and measure the amount of fuel discharged.

Battery (+) terminal — Power source lead wire ①  
(Yellow with black tracer)

If the pump does not discharge the amount specified, it means that the fuel pump is defective or that the fuel filter is clogged.

**DATA** Fuel discharge amount: MIN. 168 ml  
(5.7/5.9 US/lmp oz)/10 sec.

### NOTE:

The battery must be in fully charged condition.

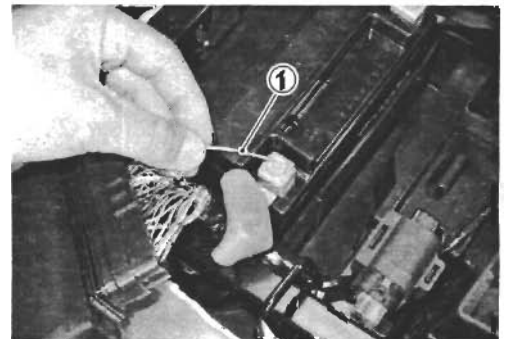

## FUEL PUMP RELAY INSPECTION

Fuel pump relay is located behind the ECM.

- Remove the seat. (☞ 7-4)
- Remove the fuel pump relay.

First, check the insulation between ① and ② terminals with pocket tester. Then apply 12 volts to ③ and ④ terminals,  $\oplus$  to ③ and  $\ominus$  to ④, and check the continuity between ① and ②.

If there is no continuity, replace it with a new one.

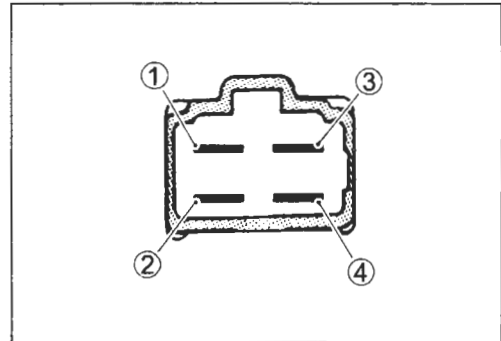
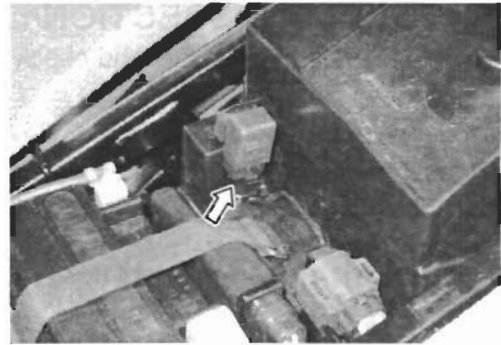

## FUEL PUMP AND FUEL FILTER REMOVAL

- Remove the fuel tank. (☞ 5-7)
- Remove the fuel pump assembly by removing its mounting bolts diagonally.

### ⚠ WARNING

Gasoline is highly flammable and explosive.  
Keep heat, spark and flame away.

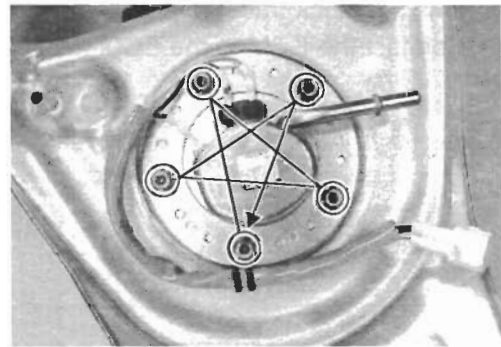

- Remove the screws.



- Remove the nuts ① and screw ②.
- Disconnect the clamp ③.
- Remove the fuel level gauge.

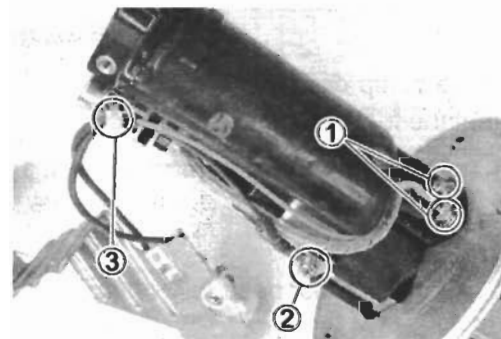

- Remove the screws.

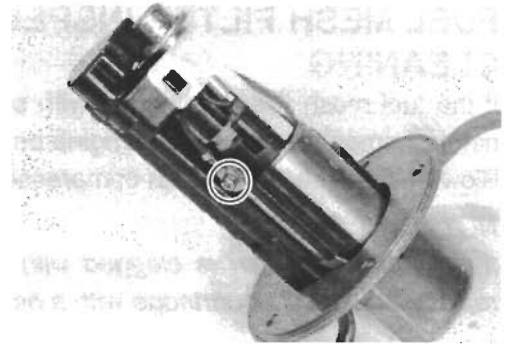

- Remove the fuel pump assy ④ from the fuel pump plate ⑤.

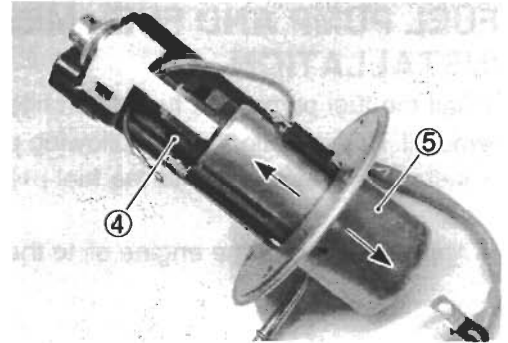

- Remove the fuel pump holder ⑥.

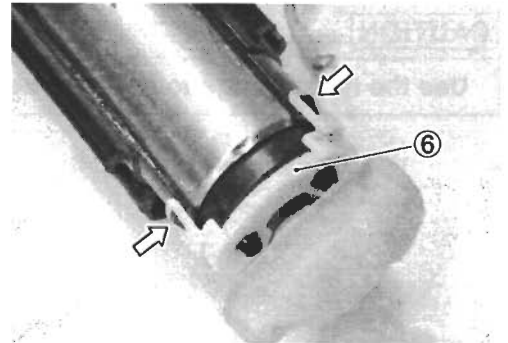

- Remove the fuel mesh filter ⑦.

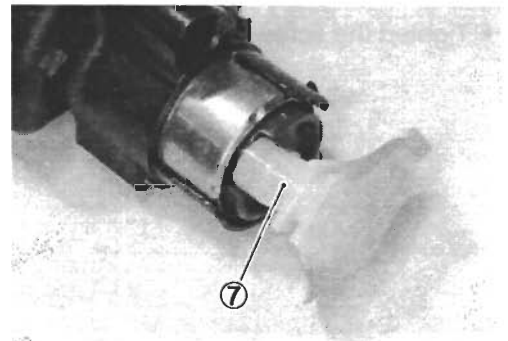

- Remove the fuel pressure regulator holder ⑧ and the fuel pressure regulator ⑨.

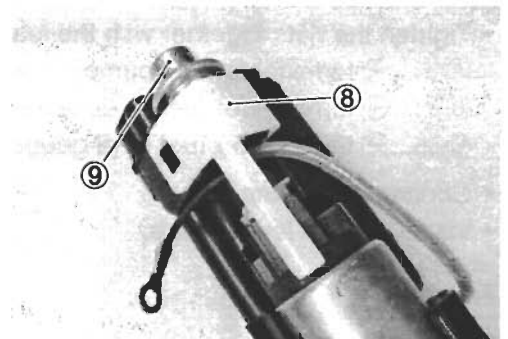

## FUEL MESH FILTER INSPECTION AND CLEANING

If the fuel mesh filter is clogged with sediment or rust, fuel will not flow smoothly and loss in engine power may result. Blow the fuel mesh filter with compressed air.

### NOTE:

If the fuel mesh filter is clogged with many sediment or rust, replace the fuel filter cartridge with a new one.

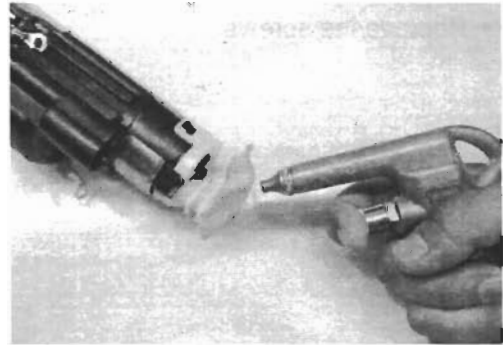

## FUEL PUMP AND FUEL MESH FILTER INSTALLATION

Install the fuel pump and fuel mesh filter in the reverse order of removal. Pay attention to the following points:

- Install the new O-rings to the fuel pressure regulator and fuel pipe.
- Apply thin coat of the engine oil to the O-rings.

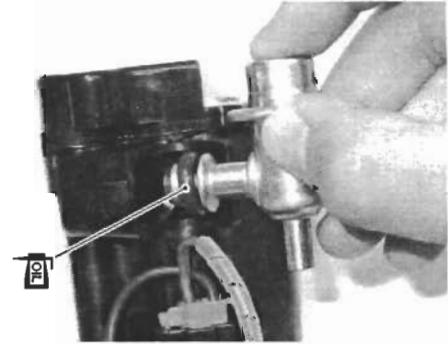

### CAUTION

Use the new O-rings to prevent fuel leakage.

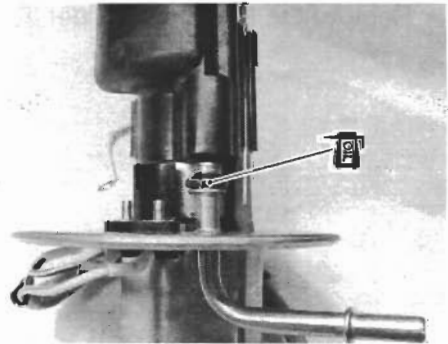

- Tighten the screw together with the lead wire terminal.

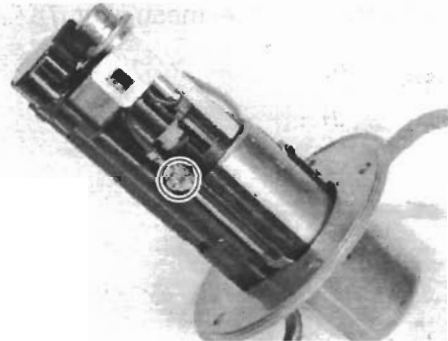

- Tighten the nuts together with the lead wire terminals.
  - Ⓐ .....⊕ terminal for fuel pump
  - Ⓑ .....⊕ terminal for fuel level gauge
  - Ⓒ .....⊖ terminal for fuel level gauge
- Connect the clamp ①.
- Install the fuel level gauge.

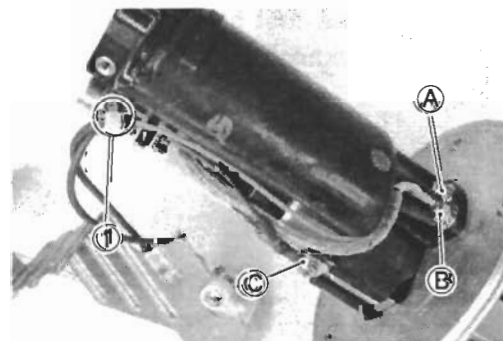

- Install the new O-ring and apply SUZUKI SUPER GREASE to it.

**⚠ WARNING**

The O-ring must be replaced with a new one to prevent fuel leakage.

- **Ⓐ** 99000-25030: SUZUKI SUPER GREASE "A" (USA)  
99000-25010: SUZUKI SUPER GREASE "A" (Others)

- When installing the fuel pump assembly, first tighten all the fuel pump assembly mounting bolts lightly in the ascending order of numbers, and then tighten them to the specified torque in the above tightening order

**🔧 Fuel pump mounting bolt: 10 N-m (1.0 kgf-m, 7.3 lb-ft)**

**NOTE:**

Apply a small quantity of the **THREAD LOCK** to the thread portion of the fuel pump mounting bolt.

- **🔧 1342** 99000-32050: **THREAD LOCK "1342"**

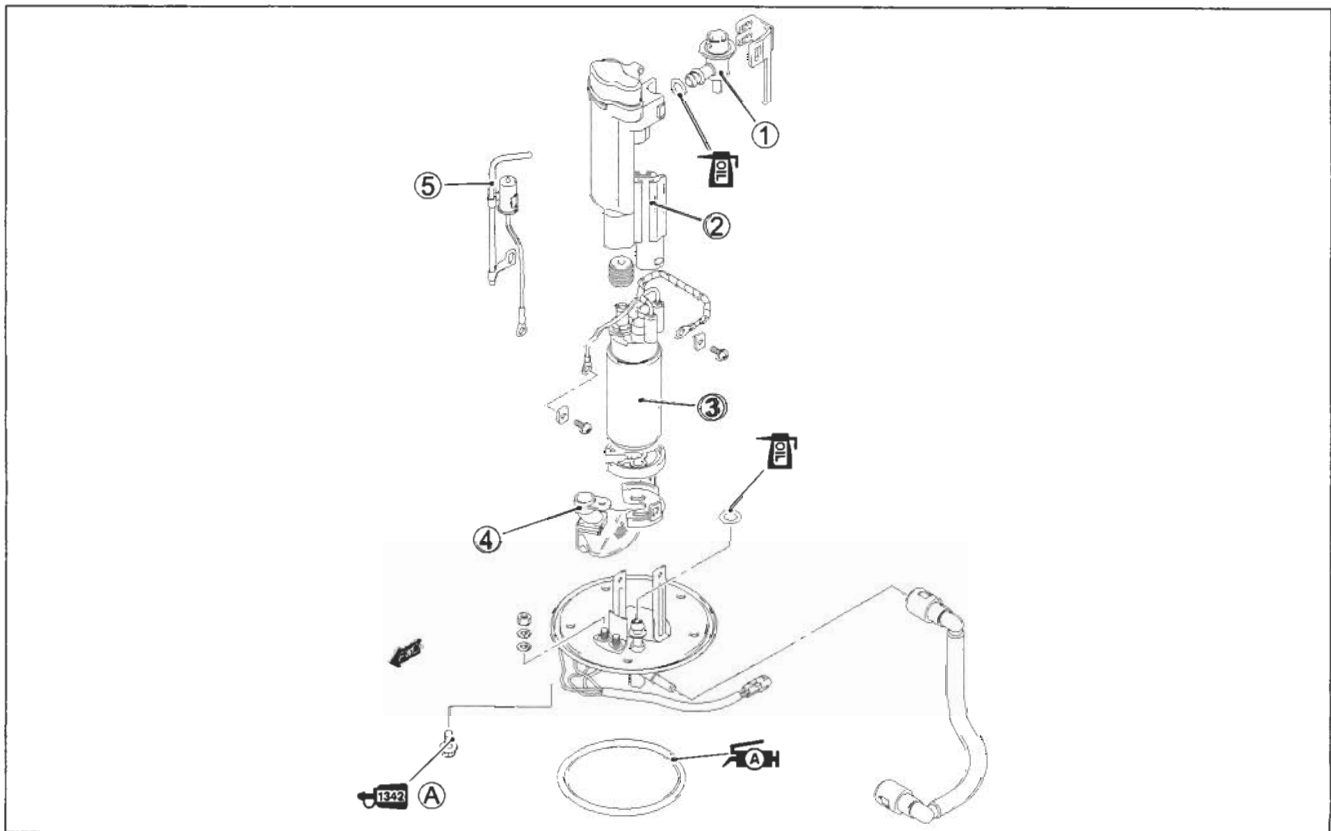
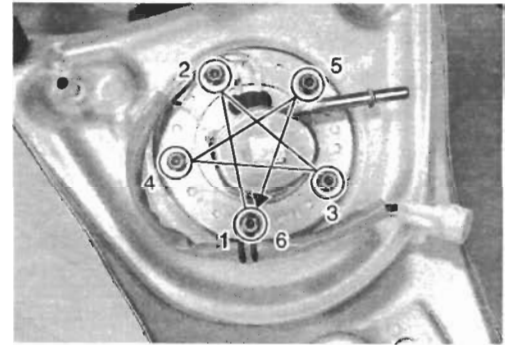
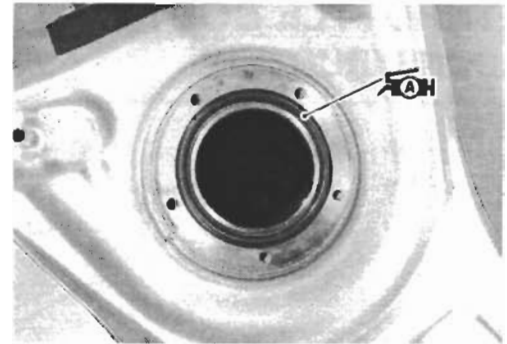

①	Fuel pressure regulator	④	Fuel mesh filter (For low pressure)
②	Fuel pump case/Fuel filter cartridge (For high pressure)	⑤	Fuel level gauge
③	Fuel pump	Ⓐ	Fuel pump mounting bolt

ITEM	N-m	kgf-m	lb-ft
Ⓐ	10	1.0	7.3

# THROTTLE BODY AND STV ACTUATOR CONSTRUCTION

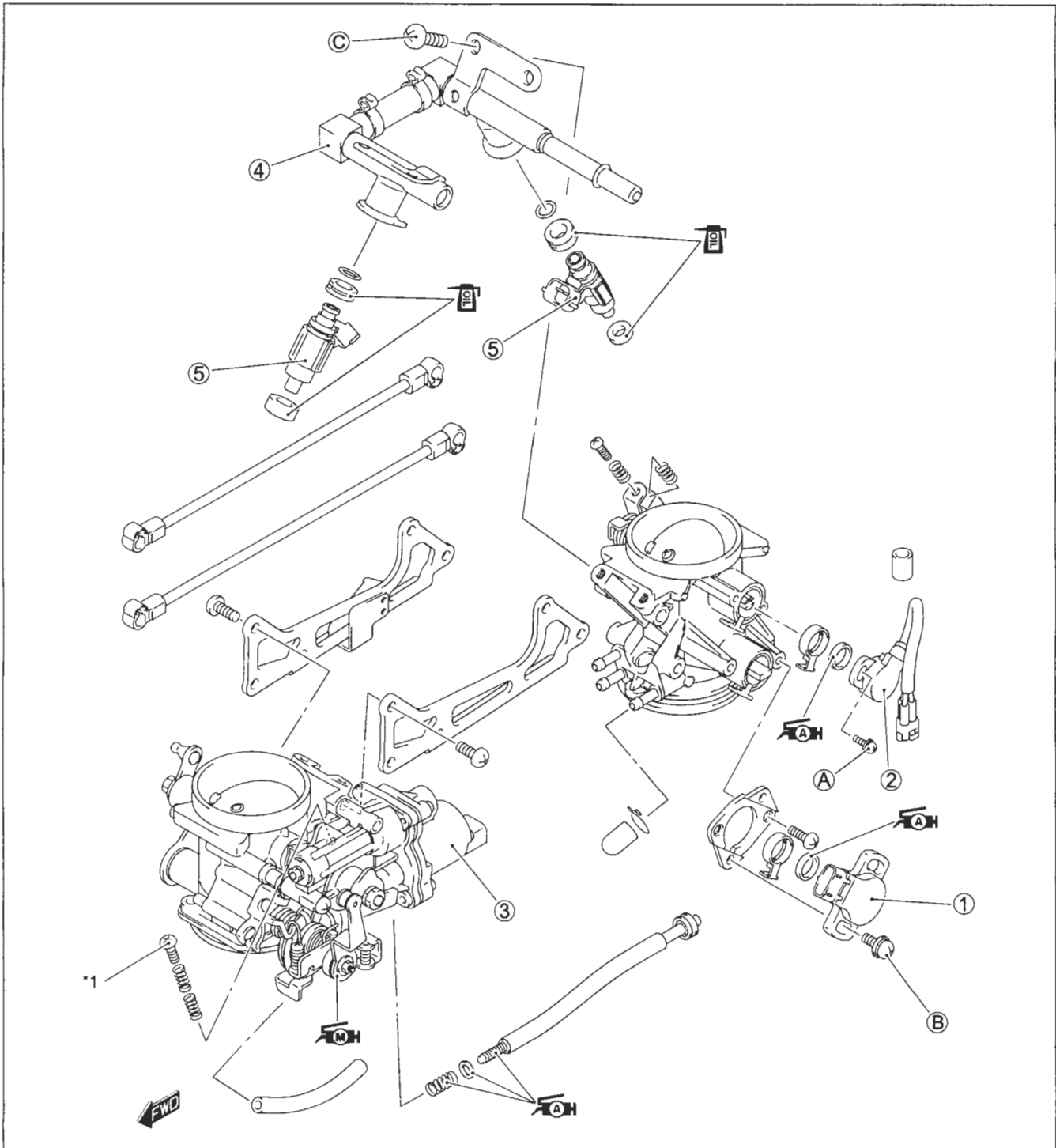

①	TP sensor	A	STP sensor mounting screw
②	STP sensor	B	TP sensor mounting screw
③	STVA	C	Fuel delivery pipe mounting screw
④	Fuel delivery pipe	*1	Do not turn the screw.
⑤	Injector		

ITEM	N·m	kgf·m	lb·ft
A	2.0	0.2	1.5
B	3.5	0.35	2.5
C	5.0	0.5	3.7



## AIR CLEANER AND THROTTLE BODY REMOVAL

### AIR CLEANER BOX

- Remove the fuel tank. (☞ 5-7)
- Disconnect the IAT sensor coupler ①.
- Remove the IAP sensor vacuum hose ②.
- Disconnect the IAP sensor coupler ③.

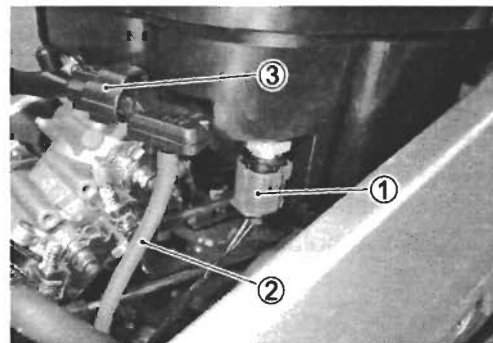

- Loosen the throttle body clamp screws.

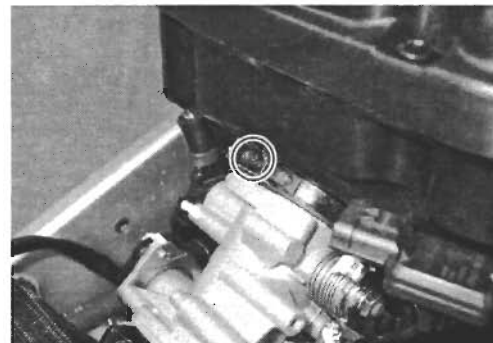

- Disconnect the PAIR hose.
- Disconnect the PAIR lead wire coupler ④.

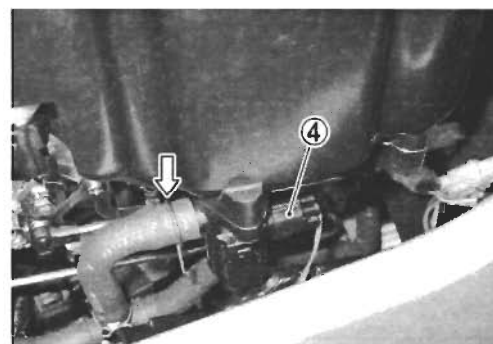

- Disconnect the crankcase breather hoses.
- Remove the air cleaner box.

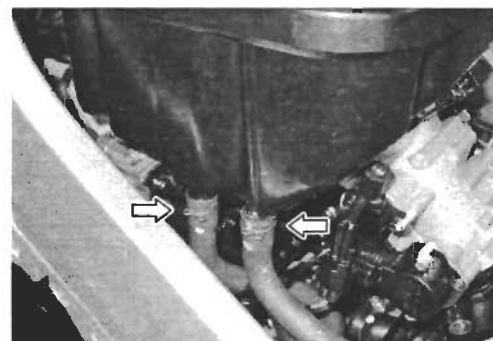

**THROTTLE BODY**

- Remove the fuel tank. (☞ 5-7)
- Remove the air cleaner box. (☞ 5-15)
- Disconnect the various lead wire couplers.
  - ① TP sensor
  - ② STP sensor
  - ③ STVA motor

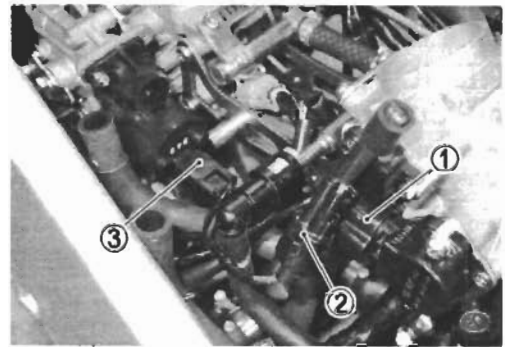

- Remove the injector lead wire coupler.

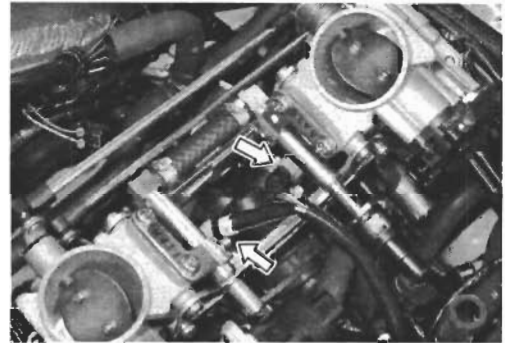

- Disconnect the idle stop screw.

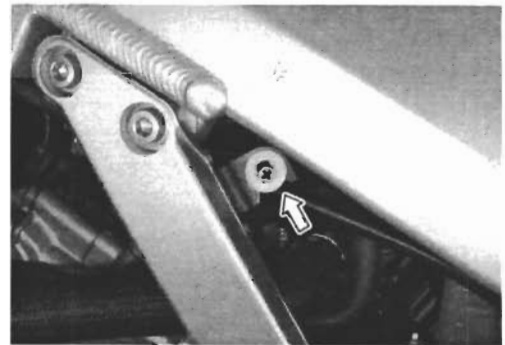

- Loosen the throttle body clamp screws.

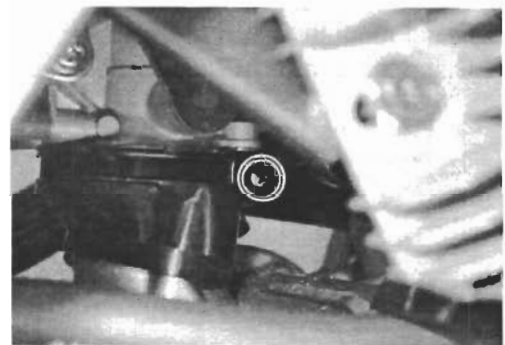

- Disconnect the throttle cables from their drum.
- Dismount the throttle body assembly.

**CAUTION**

- \* Be careful not to damage the throttle cable bracket and fast idle lever when dismantling or remounting the throttle body assembly.
- \* After disconnecting the throttle cables, do not snap the throttle valve from full open to full close. It may cause damage to the throttle valve and throttle body.

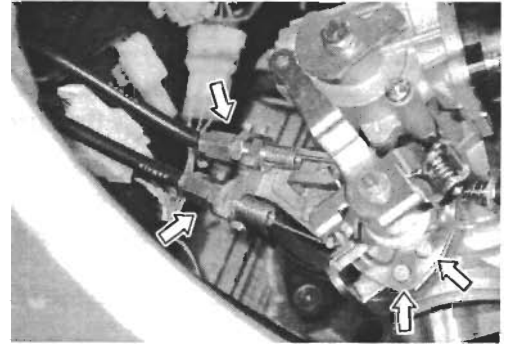

## THROTTLE BODY DISASSEMBLY

### CAUTION

- \* Be careful not to damage the throttle lever when disassembling the throttle body.
- \* The throttle body is assembled precisely in factory. Do not disassemble it other than shown in this manual.

- Remove the IAP sensor vacuum damper and its hose.
- Disconnect the fuel feed hose ①.

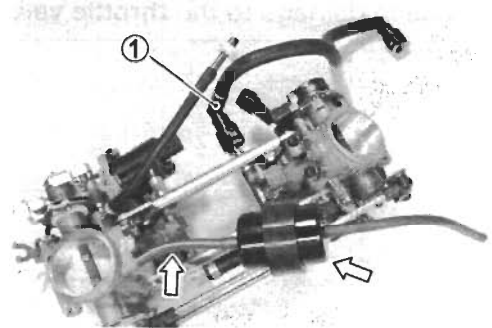

- Remove the throttle link rod ② and secondary throttle link rod ③.

**NOTE:**

The throttle link rod ② is longer than the secondary throttle link rod ③.

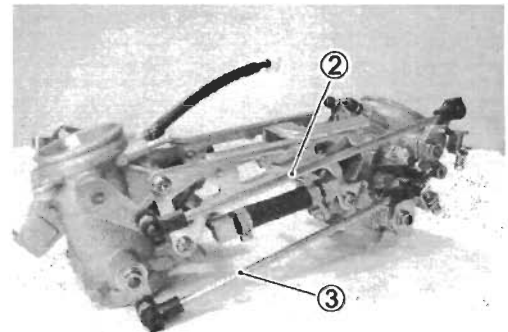

- Remove the fuel delivery pipe ④.

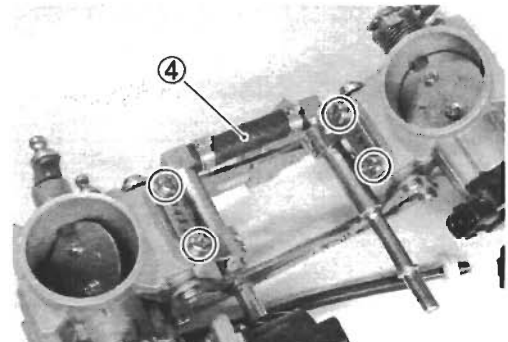

- Remove the fuel injectors.

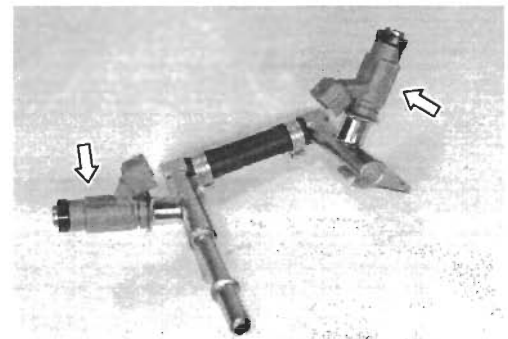

- Remove the TPS ⑤ and STPS ⑥ with the special tool.

**TOOL** 09930-11950: Torx wrench (TH 25)  
 09930-11960: Torx wrench (TH 20)

**NOTE:**

*Prior to disassembly, mark each sensor's original position with a paint or scribe for accurate reinstallation.*

- Remove the oil seals ⑦.

**CAUTION**

Do not turn the screws ⑧.

**CAUTION**

Never remove the STVA.

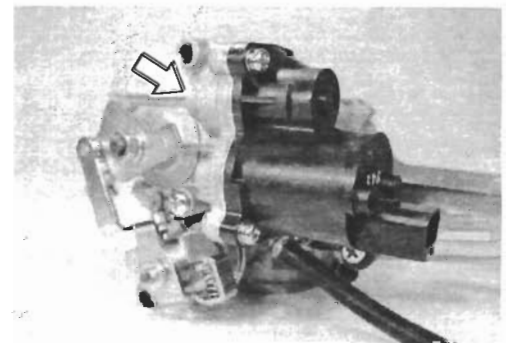
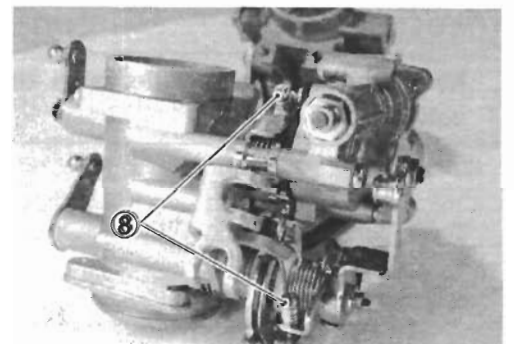
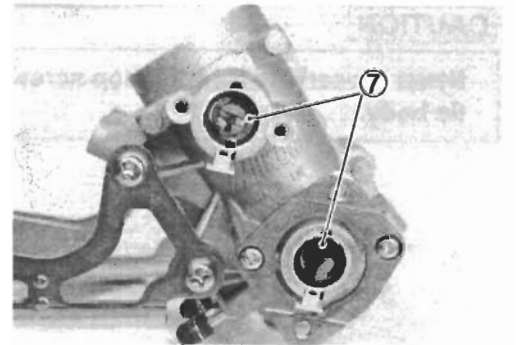
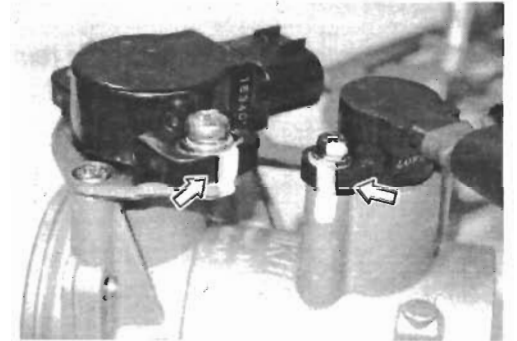
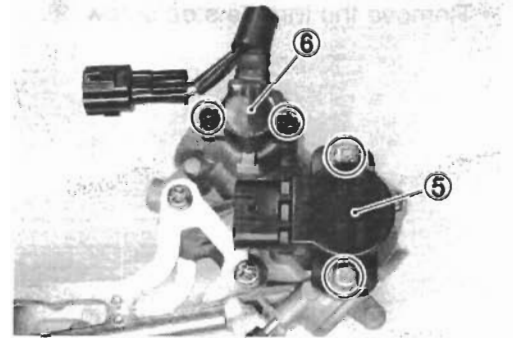

- Remove the throttle stop screw ⑨.

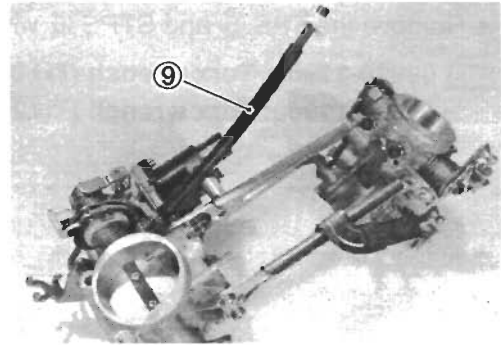

**NOTE:**  
Measure the length ① for accurate reinstallation.

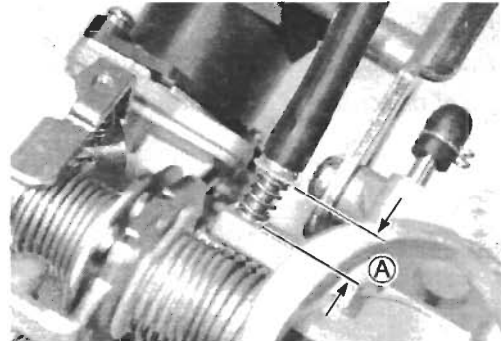

**CAUTION**

Never loosen the throttle stop screw ② on the No.2 throttle body.

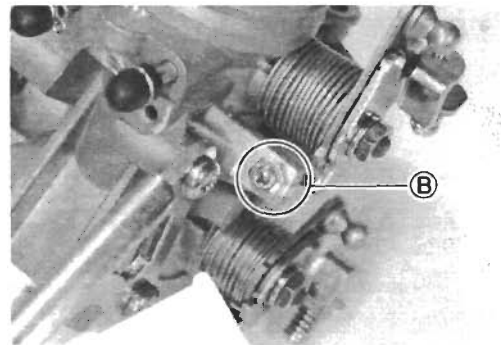

**CAUTION**

Never remove the throttle valve and secondary throttle valve.

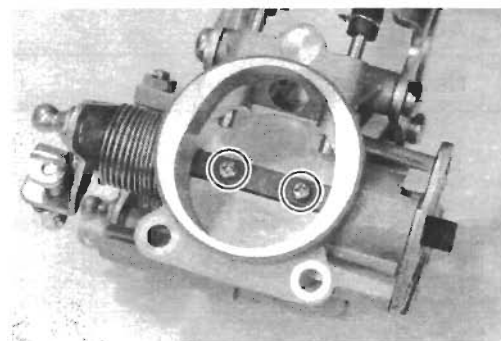
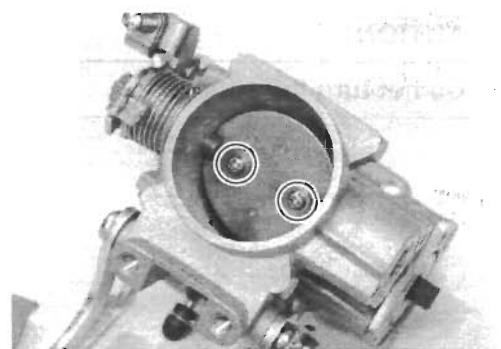

**CAUTION**

Never remove the throttle body link plates.

- Remove the fast idle link lever ⑩.

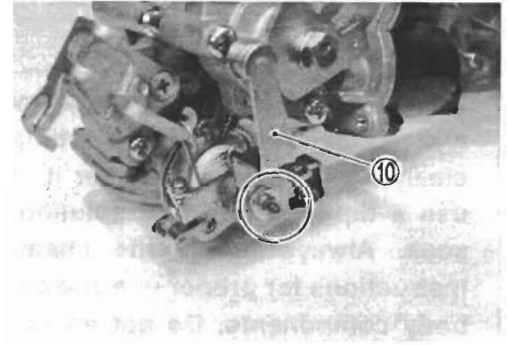
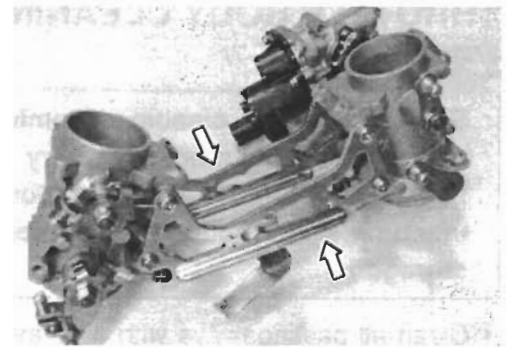

- Remove the spring ⑪.

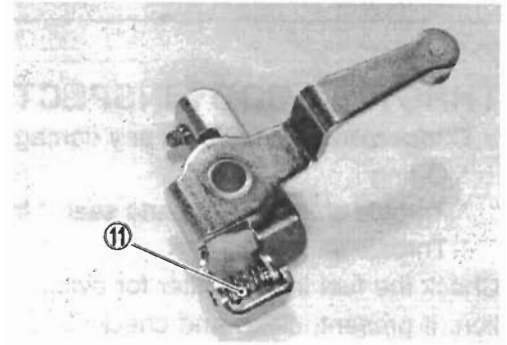

- Remove the spring ⑫, bushing ⑬ and plastic washer ⑭.

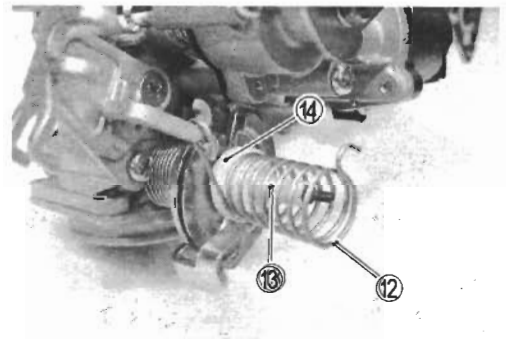

## THROTTLE BODY CLEANING

### ⚠ WARNING

Some carburetor cleaning chemicals, especially dip-type soaking solutions, are very corrosive and must be handled carefully. Always follow the chemical manufacturer's instructions on proper use, handling and storage.

- Clean all passageways with a spray type carburetor cleaner and blow dry with compressed air.

### CAUTION

Do not use wire to clean passageways. Wire can damage passageways. If the components cannot be cleaned with a spray cleaner it may be necessary to use a dip-type cleaning solution and allow them to soak. Always follow the chemical manufacturer's instructions for proper use and cleaning of the throttle body components. Do not apply carburetor cleaning chemicals to the rubber and plastic materials.

## THROTTLE BODY INSPECTION

- Check following items for any damage or clogging.
 

* O-ring	* Secondary throttle valve
* Throttle shaft bushing and seal	* Injector cushion seal
* Throttle valve	* Vacuum hose

Check the fuel injector filter for evidence of dirt and contamination. If present, clean and check for presence of dirt in the fuel lines and fuel tank.

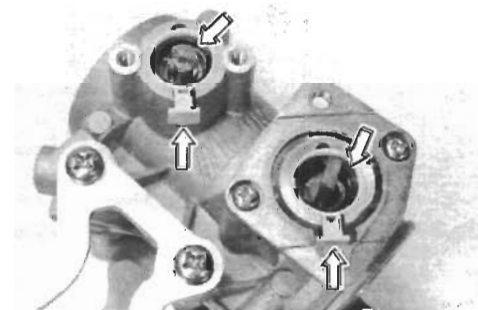
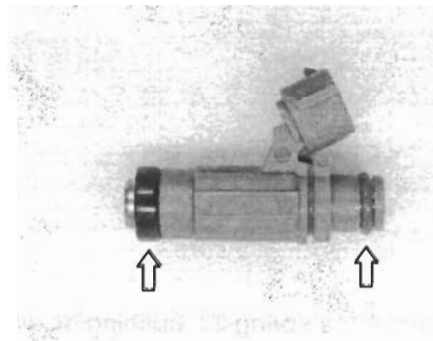



## THROTTLE BODY REASSEMBLY

Reassemble the throttle body in the reverse order of disassembly.

Pay attention to the following points:

- Apply SUZUKI SUPER GREASE to the throttle stop screw tip and the both ends of a spring.

 **99000-25030: SUZUKI SUPER GREASE "A" (USA)**  
**99000-25010: SUZUKI SUPER GREASE "A" (Others)**

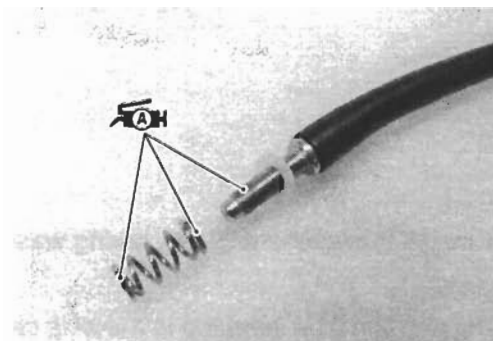

- Install the plastic washer ① and bushing ②.

**NOTE:**

*The concave of a bushing is faced outside.*

- Install the spring.

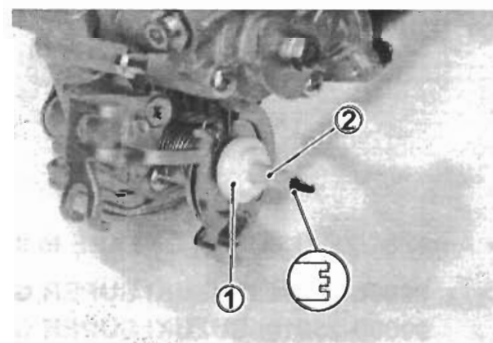

- Apply SUZUKI MOLY PASTE to the fast idle link lever.

 **99000-25140: SUZUKI MOLY PASTE**

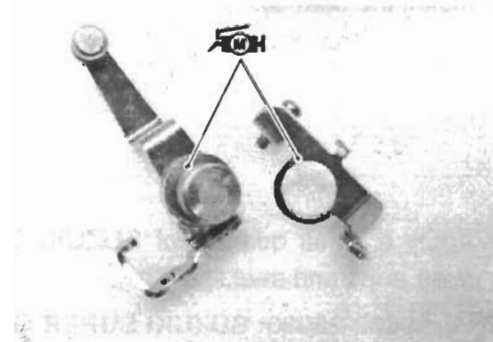

- Install the spring ③.

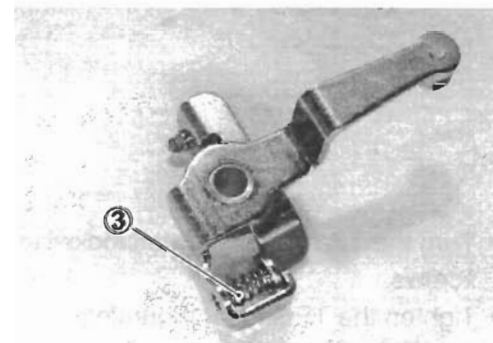

- Install the spring ④ and fast idle link lever ⑤.

**NOTE:**

*Make sure that the spring ends are hooked correctly.*

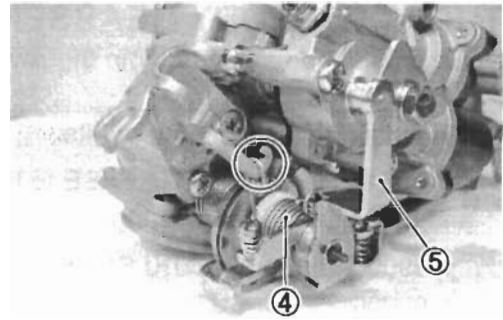

- Install the washers ⑤, ⑥, spring washer ⑦ and nut ⑧.

**NOTE:**

*The washer ⑤ is inserting in the axis certainly.*

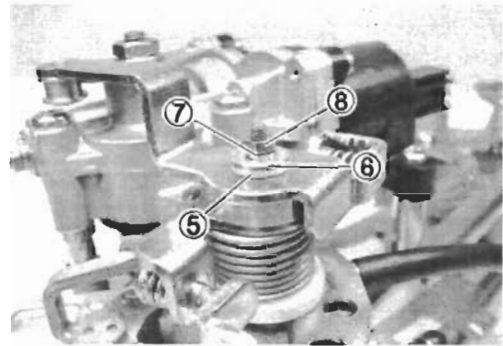

- Apply SUZUKI SUPER GREASE to the seal lips.

**FAH 99000-25030: SUZUKI SUPER GREASE "A" (USA)**  
**99000-25010: SUZUKI SUPER GREASE "A" (Others)**

- Install the seal ⑨.

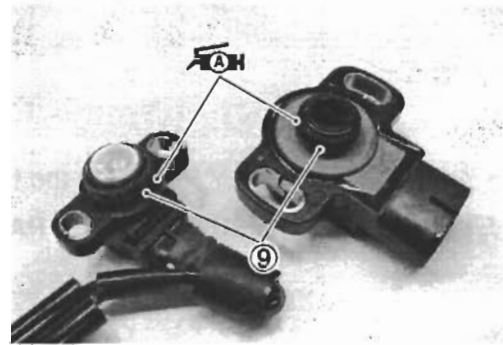

- Apply a small quantity of SUZUKI SUPER GREASE to the shaft ends and seal lips.

**FAH 99000-25030: SUZUKI SUPER GREASE "A" (USA)**  
**99000-25010: SUZUKI SUPER GREASE "A" (Others)**

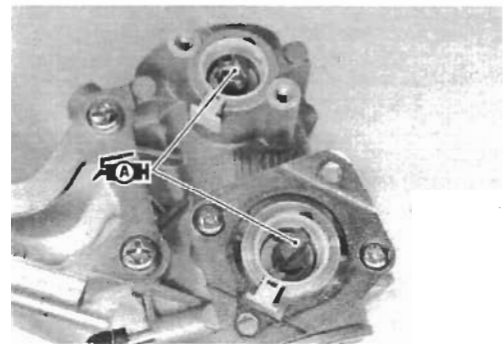

- Turn the TP sensor counterclockwise and install the mounting screws.
- Tighten the TP sensor mounting screws.

**TOOL 09930-11950: Torx wrench**

**TP sensor mounting screw: 3.5 N·m (0.35 kgf·m, 2.5 lb·ft)**

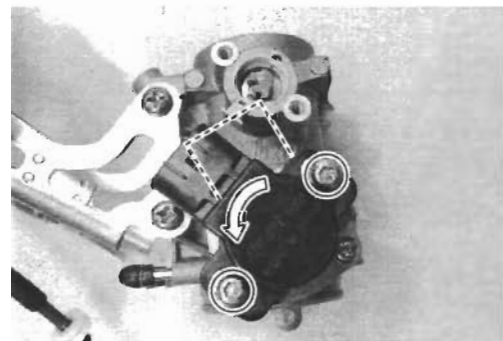

**NOTE:**

*Make sure the throttle valve open or close smoothly.*

- Align the boss ① of the STP sensor with the groove ② of the ST valve shaft.
- Install the STP sensor.

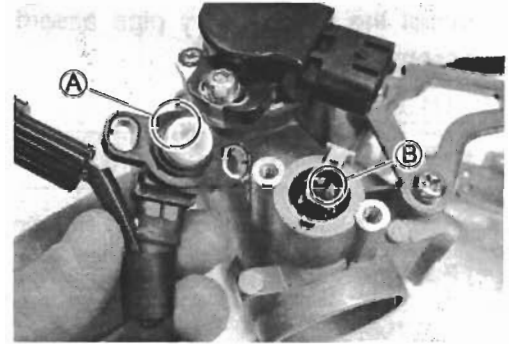
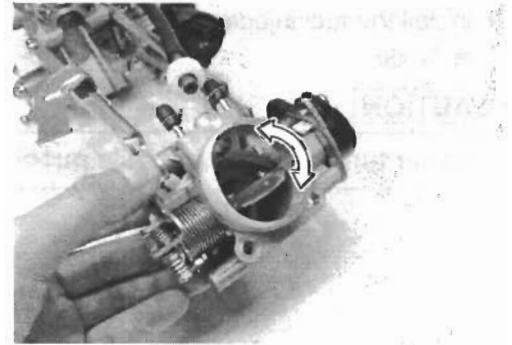

- Tighten the STP sensor mounting screws.

 **09930-11960: Torx wrench**

 **STP sensor mounting screw:**

**2.0 N·m (0.2 kgf-m, 1.5 lb-ft)**

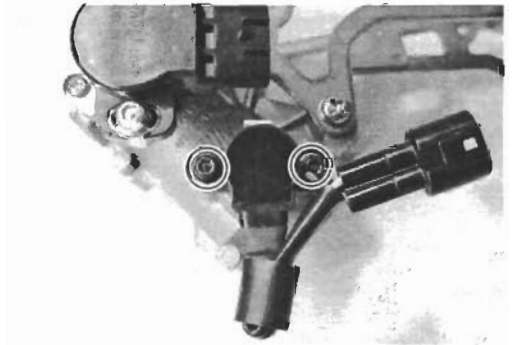
**NOTE:**

*Make sure the ST valve open or close smoothly.*

- Apply thin coat of the engine oil to the new fuel injector cushion seal ⑩, and install it to the fuel injector.

**CAUTION**

**Replace the cushion seal and O-ring with a new one.**

- Install the O-ring ⑪ to the fuel injector.
- Apply thin coat of the engine oil to the new O-ring ⑪.

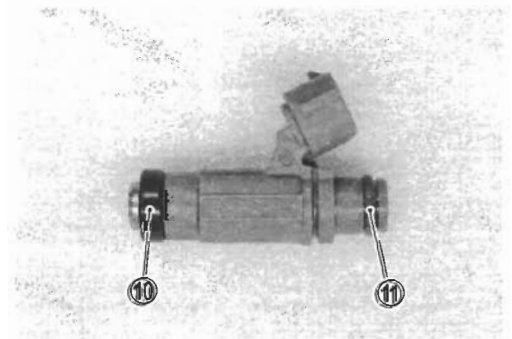

- Install the fuel injectors by pushing them straight to each throttle body.

**CAUTION**

**Never turn the injector while pushing it.**

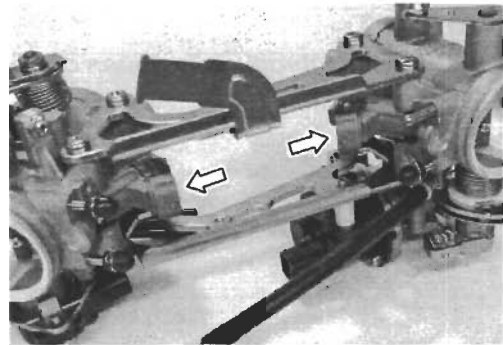

- Install the fuel delivery pipe assembly to the throttle body assembly.

**CAUTION**

**Never turn the fuel injectors while installing them.**

- Tighten the fuel delivery pipe mounting screws.

**Fuel delivery pipe mounting screw:**  
5.0 N·m (0.5 kgf-m, 3.7 lb-ft)

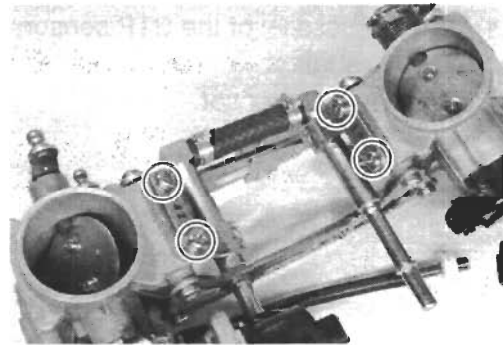

- Install the throttle link rod ⑫ and secondary throttle link rod ⑬.

**NOTE:**  
The throttle link rod ⑫ is longer than the secondary throttle link rod ⑬.

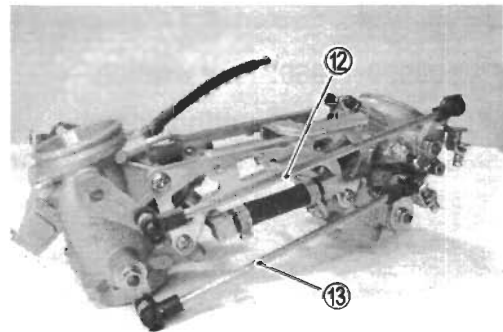

- Install the IAP sensor vacuum damper and hose.

**CAUTION**

**The stamp © of the IAP sensor vacuum damper faces into the throttle body side.**

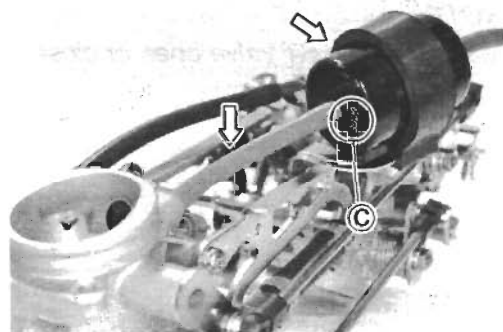

## STV SYNCHRONIZATION

- Install the throttle body. (☞ 5-27)
- Turn the ignition switch OFF, if STV synchronization is performed on the vehicle.
- Turn the STVA shaft with a finger so that the throttle valve height (A) will be same as (B).

### CAUTION

Do not use the tool for turning the STVA shaft to prevent breakdown.

### NOTE:

Measure the throttle valve height (A), (B) from top of the throttle body (1) to the throttle valve (2).

- While holding above No.1 STV position, turn the adjust screw (3) so that the throttle valve height (C) will be same as (D).

## THROTTLE BODY INSTALLATION

Installation is in the reverse order of removal. Pay attention to the following points:

- Connect the throttle pulling cable and throttle returning cable to the throttle cable drum.

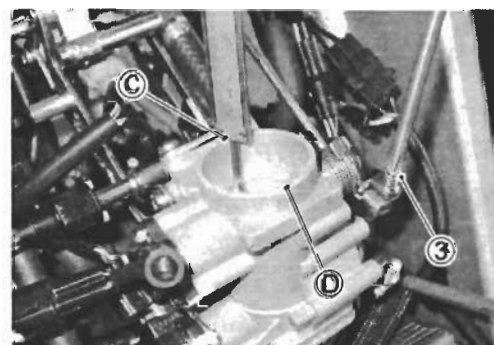
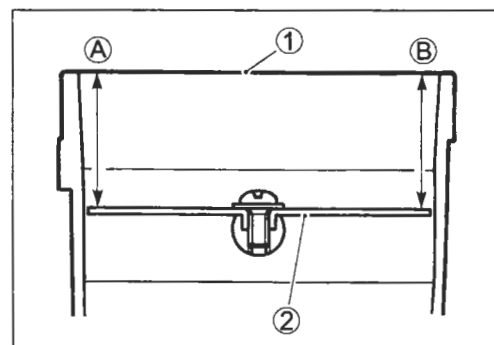
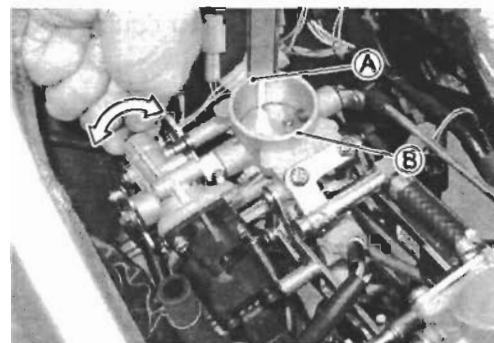

- Connect the fuel injector couplers to the fuel injectors.

**NOTE:**

- \* The fuel injector coupler No.1 (FRONT) can be distinguished from that of the No.2 (REAR) by the "F" mark (A).
- \* Adjust the throttle cable play with the cable adjusters. Refer to page 2-15 for details.

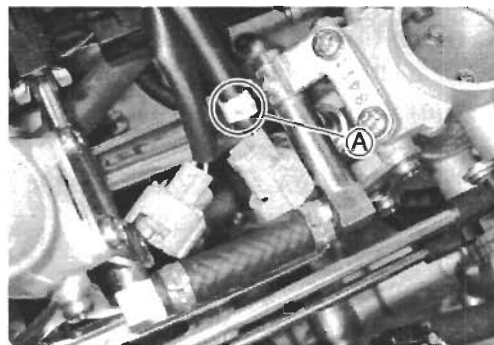
**STP SENSOR ADJUSTMENT**

If the STP sensor adjustment is necessary, measure the sensor resistance and adjust the STP sensor positioning as follows:

- Disconnect the STVA coupler ① and turn the ignition switch ON.

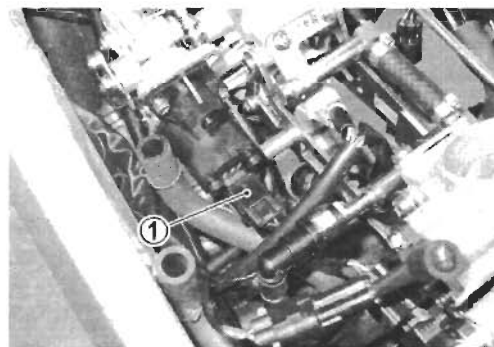

- To set the ST valve to fully open position.
- Measure the STP sensor voltage at fully open position.

**DATA** STP sensor voltage

ST valve is fully opened: Approx. 4.38 V and more  
(Yellow – Black)

- TOOL** 09900-25008: Multi circuit tester set
- 09900-25009: Needle pointed probe set

**TESTER** Tester knob indication: Voltage (---)

**CAUTION**

Do not use the tool for turning the STVA shaft to prevent breakdown.

- Loosen the STP sensor mounting screws.
- Adjust the STP sensor until voltage is within specification and tighten the STP sensor mounting screws.

**TOOL** 09930-11960: Torx wrench

**SCREW** STP sensor mounting screw:  
2.0 N·m (0.2 kgf-m, 1.5 lb-ft)

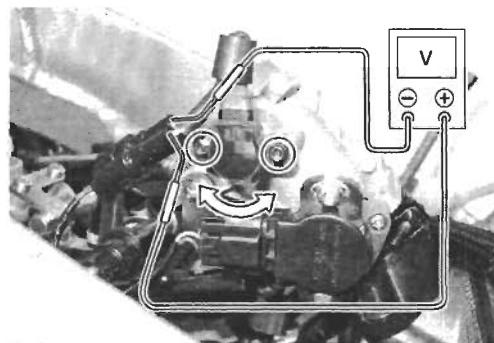
**AIR CLEANER BOX INSTALLATION**

Installation is in the reverse order of removal.

## TP SENSOR ADJUSTMENT

After checking or adjusting the throttle valve synchronization, adjust the TP sensor positioning as follows:

- After warming up engine, adjust the idling speed to 1 300 rpm.
- Stop the warmed-up engine and connect the special tool to the dealer mode coupler. (☞ 5-20)

 **09930-82720: Mode select switch**

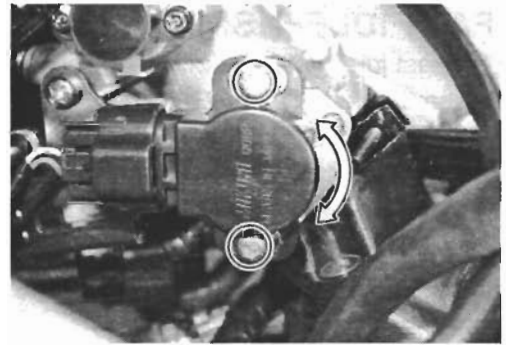

- If the TP sensor adjustment is necessary, loosen the TP sensor mounting screws.
- Turn the TP sensor and bring the line to middle.
- Tighten the TP sensor mounting screws.

 **09930-11950: Torx wrench**

 **TP sensor mounting screw: 3.5 N·m (0.35 kgf·m, 2.5 lb-ft)**

- Ⓐ Incorrect
- Ⓑ Correct position

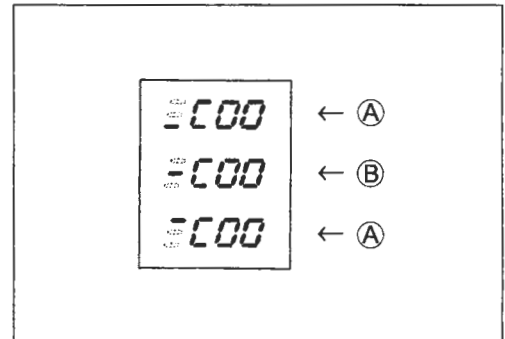

## FAST IDLE INSPECTION

The fast idle system is automatic type.

When the fast idle cam is turned by the secondary throttle valve actuator, the cam pushes the lever on the throttle valve shaft causing the throttle valve to open and raise the engine speed. When the engine has warmed up, depending on the water temperature and ambient temperature as shown in the following table, the fast idle is cancelled allowing the engine to resume idle speed.

- ① Fast idle link lever
- ② Fast idle cam
- ③ STVA

**NOTE:**

*The fast idle link lever opens throttle valve a little to increase the engine speed.*

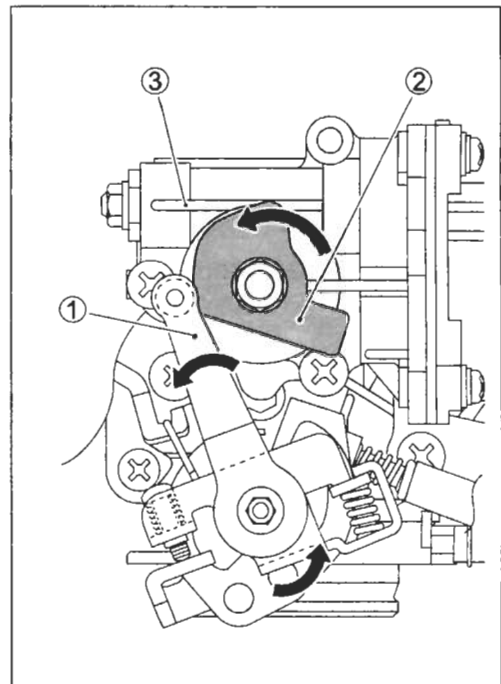

**DATA**

Fast idle rpm	Fast idle cancelling Water Temp.
1 500 – 2 000 rpm	40 – 50 °C (104 – 122 °F)

If, under the above conditions, the fast idle cannot be cancelled, the cause may possibly be short-circuit in the ECT sensor or wiring connections or maladjusted fast idle.



## FAST IDLE ADJUSTMENT

- Remove the fuel tank. (☞ 5-7)
- Remove the air cleaner box. (☞ 5-15)
- Disconnect the STVA lead wire coupler and turn the ignition switch ON.

- Open the STV fully with a finger. Measure the output voltage of the TP sensor.

### CAUTION

Do not use the tool for turning the STVA shaft to prevent breakdown.

- If the TP sensor output voltage is out of specification, turn the fast idle adjusting screw ① and adjust the output voltage to specification.

**DATA** TP sensor output voltage: 1.21 V  
(Red – B/Br)

**TOOL** 09900-25008: Multi circuit tester set  
09900-25009: Needle pointed probe set

**TESTER** Tester knob indication: Voltage (V)

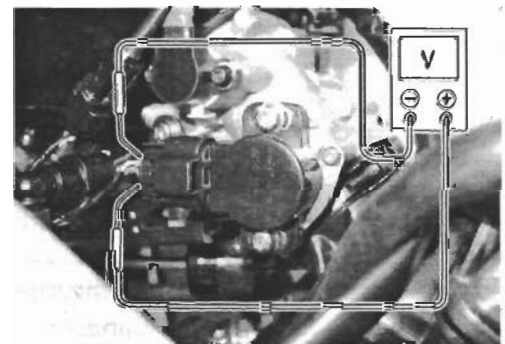
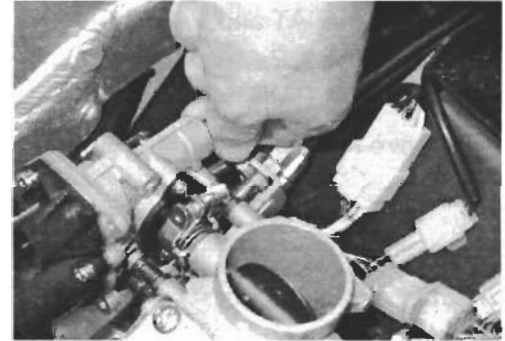
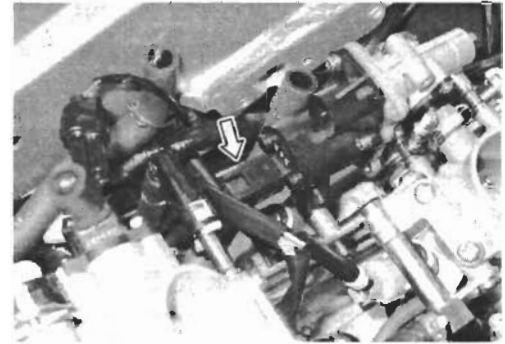

- After adjusting the fast idle speed, set the idle speed to 1 300 rpm by turning the throttle stop screw ②.



## THROTTLE VALVE SYNCHRONIZATION

Check and adjust the throttle valve synchronization between two cylinders.

### CALIBRATING EACH GAUGE (For vacuum balancer gauge)

- Start up the engine and run it in idling condition for warming up.
- Stop the warmed-up engine.
- Remove the fuel tank. (☞ 5-7)
- Remove the air cleaner box. (☞ 5-15)
- Install the fuel tank.
- Connect the IAT and PAIR control valve sensor couplers.
- Connect the IAP sensor coupler and vacuum hose.
- Connect the PAIR hose.
- Remove the rubber cap ① from the No.1 throttle body.

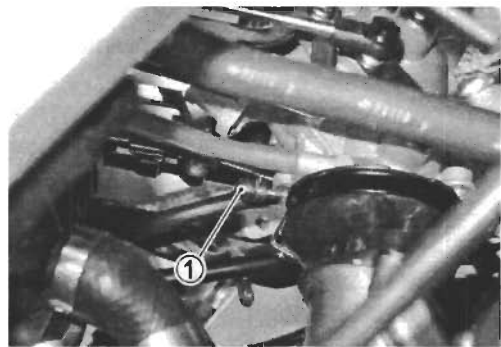

- Connect one of the four rubber hoses of the vacuum balancer gauge to the nipple on the No.1 throttle body.

**TOOL** 09913-13121: Vacuum balancer gauge

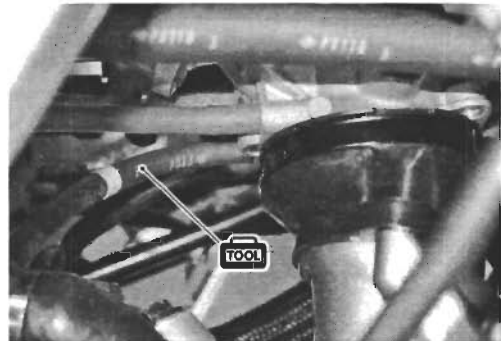

- Start up the engine and keep it running at 1 300 rpm by turning throttle stop screw ③.

### CAUTION

Avoid drawing dirt into the throttle body while running the engine without air cleaner box. Dirt drawn into the engine will damage the internal engine parts.

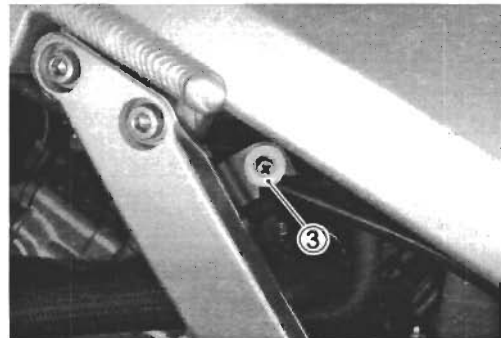

- Turn the air screw ④ of the gauge so that the vacuum acting on the tube of that hose will bring the steel ball ⑤ in the tube to the center line ⑥.

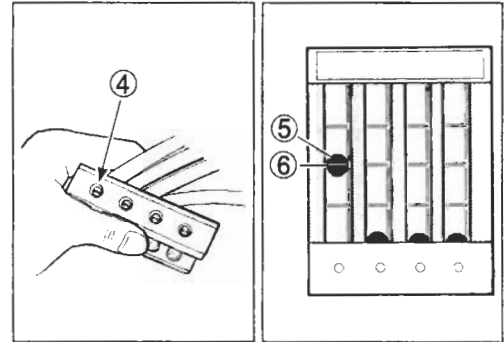

**NOTE:**

The vacuum gauge is positioned approx. 30 ° from the horizontal level.

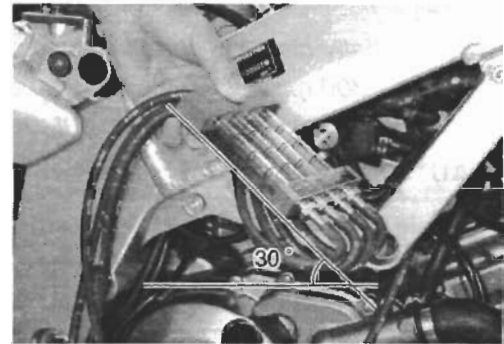

- After making sure that the steel ball stays steady at the center line, disconnect the hose from the No.1 throttle body nipple and connect the next hose of the gauge to this nipple.
- Turn air screw to bring the other steel ball ⑦ to the center line.

The balancer gauge is now ready for use in balancing the throttle valves.

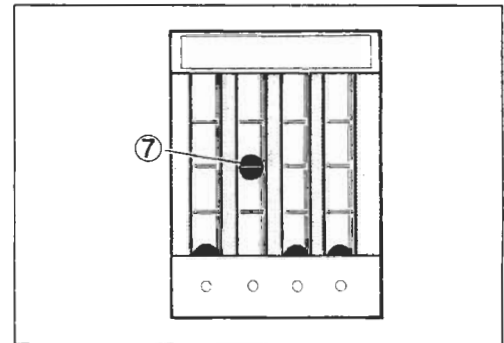

**THROTTLE VALVE SYNCHRONIZATION**

- To synchronize throttle valves, remove the rubber caps ① from each vacuum nipples on No.1 and No.2 throttle body.



- Connect the vacuum balancer gauge hoses to the vacuum nipples respectively.

 **09913-13121: Vacuum balancer gauge**

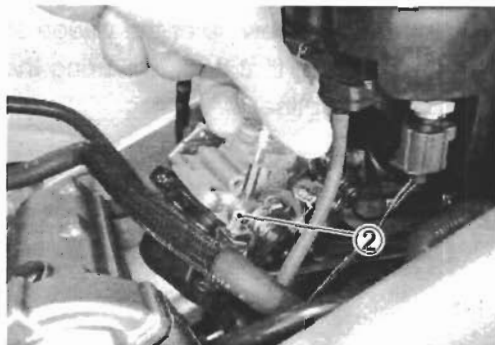

- Connect a tachometer and start up the engine.
- Bring the engine rpm to 1 300 rpm by the throttle stop screw.
- Check the vacuum of the two cylinders and balance the two throttle valves with the synchronizing screw ② on the No.2 throttle body.

**NOTE:**

- \* During balancing the throttle valves, always set the engine rpm at 1 300 rpm, using throttle stop screw.
- \* After balancing the two valves, set the idle rpm to 1 300 rpm.

**CAUTION**

**Avoid drawing dirt into the throttle body while running the engine without the air cleaner box. Dirt drawn into the engine will damage the internal engine parts.**

**NOTE:**

Make sure that the throttle lever should have a gap  $\text{\textcircled{A}}$  (between the throttle lever and throttle lever stopper screw) during synchronization.

**DATA** Throttle lever gap  $\text{\textcircled{A}}$ : 0.17 mm (0.007 in)

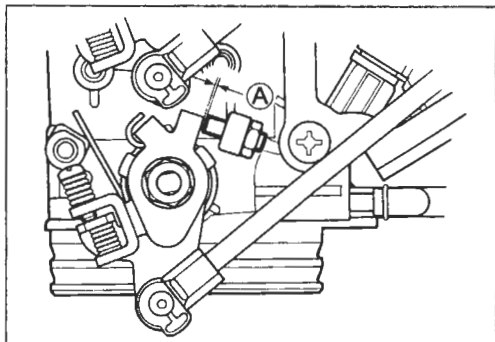

# COOLING AND LUBRICATION SYSTEM

## CONTENTS

<b>ENGINE COOLANT</b> .....	6- 2
<b>COOLING CIRCUIT</b> .....	6- 3
<b>COOLING CIRCUIT INSPECTION</b> .....	6- 3
<b>RADIATOR</b> .....	6- 4
<b>REMOVAL</b> .....	6- 4
<b>INSPECTION AND CLEANING</b> .....	6- 6
<b>INSTALLATION</b> .....	6- 6
<b>RADIATOR CAP</b> .....	6- 7
<b>INSPECTION</b> .....	6- 7
<b>WATER HOSE</b> .....	6- 7
<b>INSPECTION</b> .....	6- 7
<b>COOLING FAN</b> .....	6- 8
<b>INSPECTION</b> .....	6- 8
<b>REMOVAL</b> .....	6- 8
<b>INSTALLATION</b> .....	6- 8
<b>COOLING FAN THERMO-SWITCH</b> .....	6- 9
<b>REMOVAL</b> .....	6- 9
<b>INSPECTION</b> .....	6- 9
<b>INSTALLATION</b> .....	6- 9
<b>ECT SENSOR</b> .....	6-10
<b>REMOVAL</b> .....	6-10
<b>INSPECTION</b> .....	6-10
<b>INSTALLATION</b> .....	6-11
<b>THERMOSTAT CASE ASSEMBLY</b> .....	6-12
<b>REMOVAL</b> .....	6-12
<b>INSPECTION</b> .....	6-12
<b>INSTALLATION</b> .....	6-13
<b>WATER PUMP</b> .....	6-14
<b>REMOVAL AND DISASSEMBLY</b> .....	6-14
<b>INSPECTION</b> .....	6-16
<b>REASSEMBLY AND INSTALLATION</b> .....	6-17
<b>LUBRICATION SYSTEM</b> .....	6-20
<b>OIL PRESSURE</b> .....	6-20
<b>OIL FILTER</b> .....	6-20
<b>OIL PRESSURE REGULATOR</b> .....	6-20
<b>OIL STRAINER</b> .....	6-20
<b>OIL JET</b> .....	6-20

<b>OIL PUMP.....</b>	<b>6-20</b>
<b>OIL PRESSURE SWITCH.....</b>	<b>6-20</b>
<b>OIL COOLER.....</b>	<b>6-21</b>
<b>REMOVAL.....</b>	<b>6-21</b>
<b>INSPECTION AND CLEANING.....</b>	<b>6-21</b>
<b>INSTALLATION.....</b>	<b>6-22</b>
<b>ENGINE LUBRICATION FLOW CHART.....</b>	<b>6-23</b>
<b>ENGINE LUBRICATION CIRCUIT.....</b>	<b>6-24</b>

## ENGINE COOLANT

At the time of manufacture, the cooling system is filled with a 50:50 mixture of distilled water and ethylene glycol anti-freeze. This 50:50 mixture will provide the optimum corrosion protection and excellent heat protection, and will protect the cooling system from freezing at temperatures above  $-31\text{ }^{\circ}\text{C}$  ( $-24\text{ }^{\circ}\text{F}$ ).

If the motorcycle is to be exposed to temperatures below  $-31\text{ }^{\circ}\text{C}$  ( $-24\text{ }^{\circ}\text{F}$ ), this mixing ratio should be increased up to 55 % or 60 % according to the figure.

Anti-freeze density	Freezing point
50 %	$-31\text{ }^{\circ}\text{C}$ ( $-24\text{ }^{\circ}\text{F}$ )
55 %	$-40\text{ }^{\circ}\text{C}$ ( $-40\text{ }^{\circ}\text{F}$ )
60 %	$-55\text{ }^{\circ}\text{C}$ ( $-67\text{ }^{\circ}\text{F}$ )

### CAUTION

- \* Use a high quality ethylene glycol base anti-freeze, mixed with distilled water. Do not mix an alcohol base anti-freeze and different brands of anti-freeze.
- \* Do not put in 60 % and more anti-freeze or 50 % and less. (Refer to below figure.)
- \* Do not use a radiator anti-leak additive.

50 % Engine coolant including reserve tank capacity

Anti-freeze	950 ml (2.01/1.67 US/Imp.pt)
Water	950 ml (2.01/1.67 US/Imp.pt)

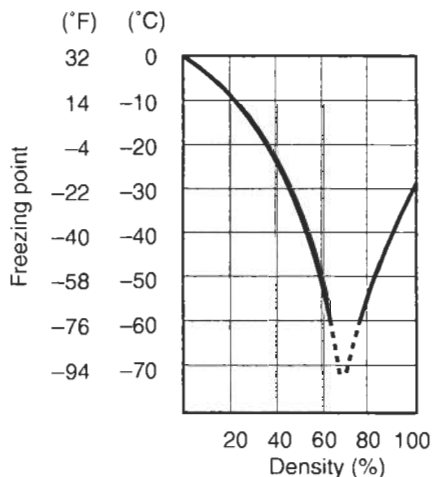

Fig.1 Engine coolant density-freezing point curve.

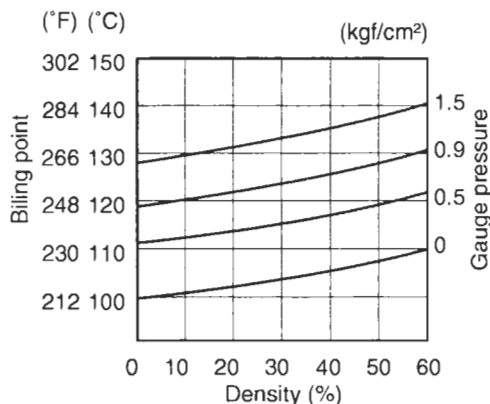
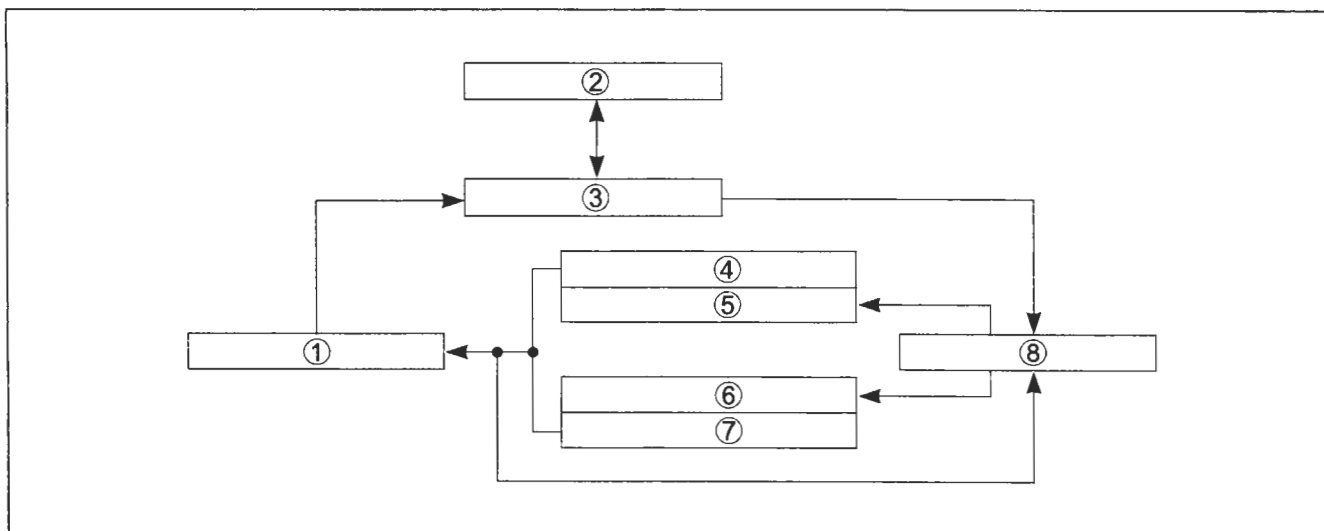

Fig.2 Engine coolant density-boiling point curve.

### WARNING

- \* You can be injured by scalding fluid or steam if you open the radiator cap when the engine is hot. After the engine cools, wrap a thick cloth around cap and carefully remove the cap by turning it a quarter turn to allow pressure to escape and then turn the cap all the way off.
- \* The engine must be cool before servicing the cooling system.
- \* Coolant is harmful;
  - If it comes in contact with skin or eyes, flush with water.
  - If swallowed accidentally, induce vomiting and call physician immediately.
  - Keep it away from children.

## COOLING CIRCUIT



- ① Thermostat   ② Reserve tank   ③ Radiator   ④ No.1 cylinder head   ⑤ No.1 cylinder  
⑥ No.2 cylinder   ⑦ No.2 cylinder head   ⑧ Water pump

## COOLING CIRCUIT INSPECTION

Before removing the radiator and draining the engine coolant, inspect the cooling circuit for tightness.

- Remove the cowling. (☞7-5)
- Remove the radiator cap ① and connect the radiator tester ② to the filler.

### ⚠ WARNING

**Do not remove the radiator cap when the engine is hot.**

- Give a pressure of about 120 kPa (1.2 kgf/cm<sup>2</sup>, 17.0 psi) and see if the system holds this pressure for 10 seconds.
- If the pressure should fall during this 10-second interval, it means that there is a leaking point in the system. In such a case, inspect the entire system and replace the leaking component or part.

### ⚠ WARNING

**When removing the radiator cap tester, put a rag on the filler to prevent spouting of engine coolant.**

### CAUTION

**Do not allow the pressure to exceed specified pressure, or the radiator can be damaged.**

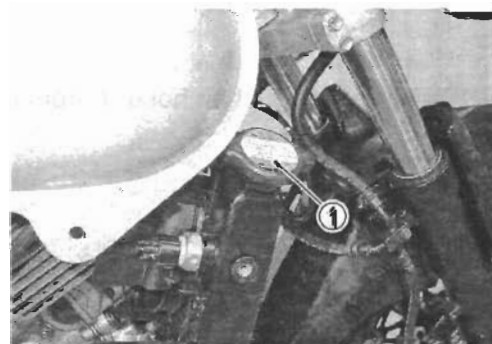



## RADIATOR

### REMOVAL

- Remove the cowling. (☞7-5)
- Drain the engine coolant. (☞2-18)
- Disconnect the right and left radiator hoses from the radiator.

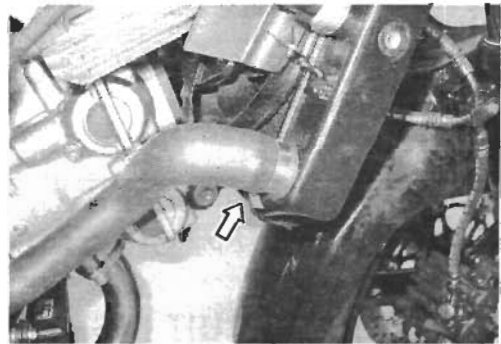
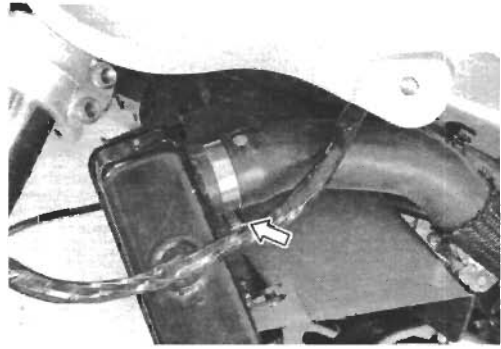

- Disconnect the siphon hose ① from the radiator.

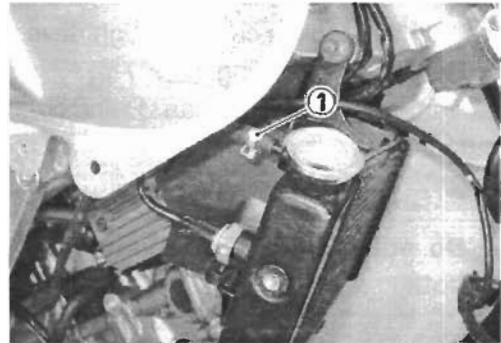

- Disconnect the horn lead wire coupler ②.

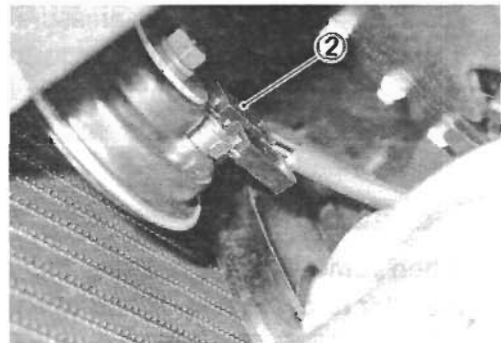

- Remove the radiator lower mounting bolt.
- Disconnect the cooling fan motor and thermo-switch lead wire coupler ③.

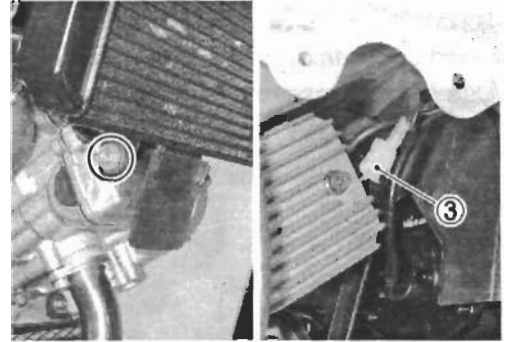

- Remove the radiator upper mounting bolt.
- Disconnect the speed sensor lead wire from the clamp ④.
- With the hooks A unlocked, remove the radiator from the radiator shroud ⑤.

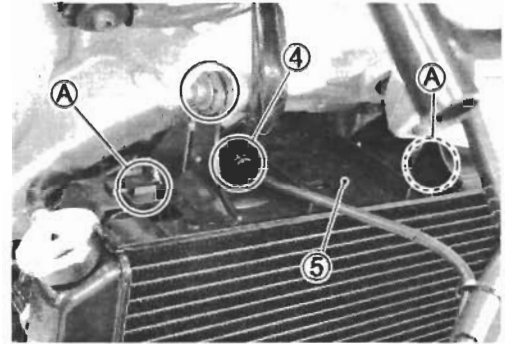

- Remove the cooling fan and thermo-switch lead wire coupler ⑥ from the radiator shroud.

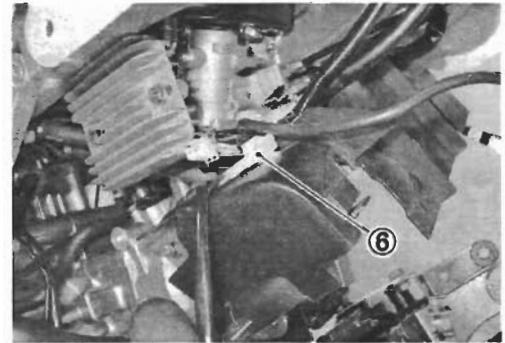

- Remove the cooling fan ⑦.
- Disconnect the cooling fan thermo-switch lead wire coupler and remove the cooling fan thermo-switch.
- Remove the horn ⑧.

#### CAUTION

When removing the horn ⑧, hold the nut by spanner to prevent the horn bracket distortion.

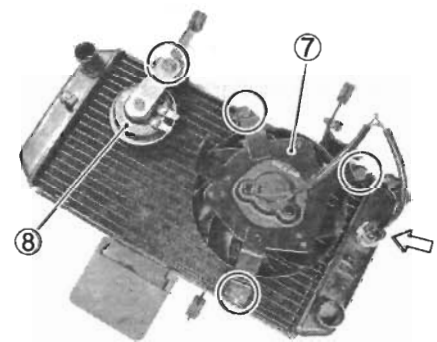

## INSPECTION AND CLEANING

Road dirt or trash stuck to the fins must be removed.  
Use of compressed air is recommended for this cleaning.

Fins bent down or dented can be repaired by straightening them with the blade of a small screwdriver.

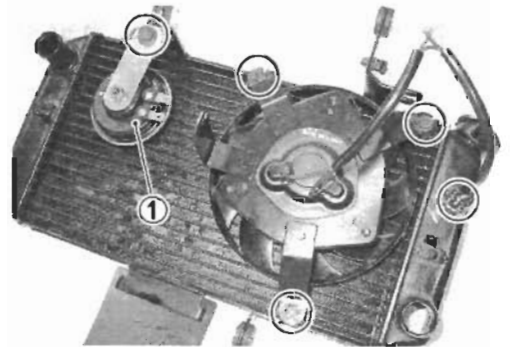
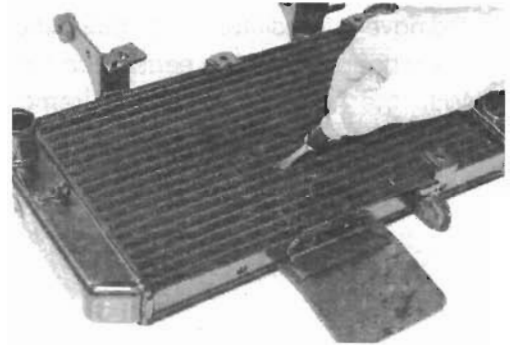
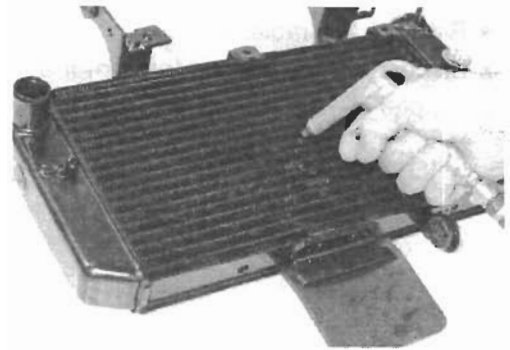

## INSTALLATION

- Install the radiator in the reverse order of removal.  
Pay attention to the following points :
- Install the cooling fan and horn ①.

### Cooling fan/horn mounting bolt:

**8 N·m (0.8 kgf·m, 6.0 lb-ft)**

- Install the cooling fan thermo-switch. (☞ 6-8)
- Route the radiator hoses properly. (☞ 9-24)
- Install the drain plug with a new sealing washer and pour engine coolant. (☞ 2-18)
- Bleed air from the cooling circuit. (☞ 2-19)
- Install the cowling. (☞ 7-8)

## RADIATOR CAP

### INSPECTION

- Remove the radiator cap. (☞6-3)
- Fit the cap ① to the radiator cap tester ②.
- Build up pressure slowly by operating the tester. Make sure that the pressure build-up stops at 95 – 125 kPa (0.95 – 1.25 kgf/cm<sup>2</sup>, 13.5 – 17.8 psi) and that, with the tester held standstill, the cap is capable of holding that pressure for at least 10 seconds.
- Replace the cap if it is found not to satisfy above requirements.

#### **DATA** Radiator cap valve opening pressure

Standard: 95 – 125 kPa

(0.95 – 1.25 kgf/cm<sup>2</sup>, 13.5 – 17.8 psi)

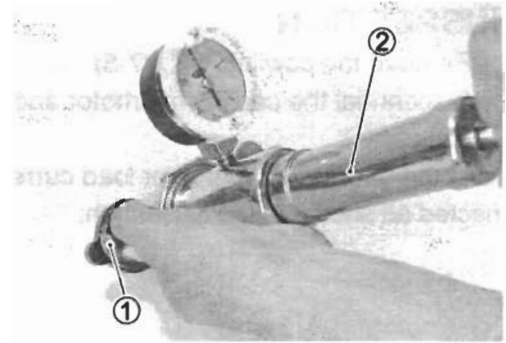

## WATER HOSE

### INSPECTION

- Remove the cowling. (☞7-5)

Any water hose found in a cracked condition or flattened or water leaked must be replaced.

Any leakage from the connecting section should be corrected by proper tightening.

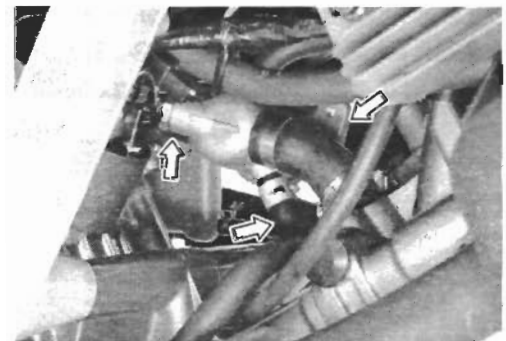
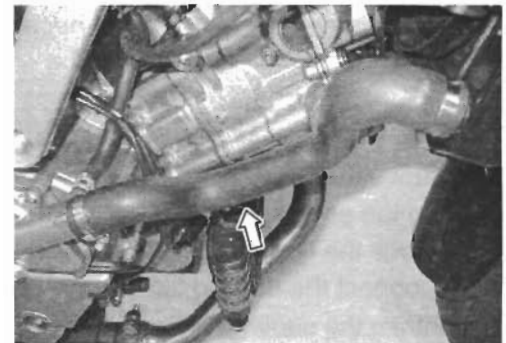

## COOLING FAN

### INSPECTION

- Remove the cowling. (☞7-5)
- Disconnect the cooling fan motor and thermo-switch lead wire coupler ①.

Test the cooling fan motor for load current with an ammeter connected as shown in the illustration.



The voltmeter is for making sure that the battery ② applies 12 volts to the fan motor ③. With the fan motor with electric motor fan running at full speed, the ammeter ④ should be indicating not 5 amperes and more.

If the fan motor does not turn, replace the fan motor assembly with a new one.

#### NOTE:

When making above test, it is not necessary to remove the cooling fan.

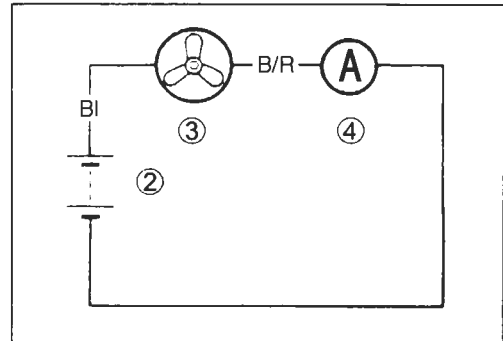

### REMOVAL

- Remove the cowling. (☞7-5)
- Drain the engine coolant. (☞2-18)
- Remove the radiator. (☞6-4)
- Disconnect the cooling fan thermo-switch coupler ①.
- Remove the cooling fan.

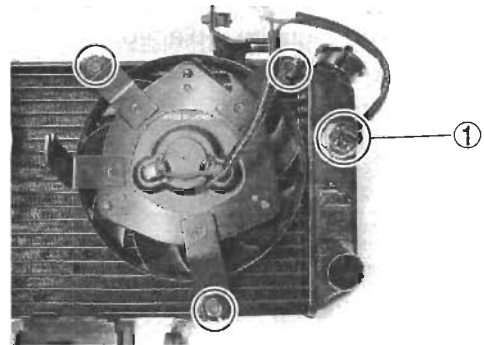

### INSTALLATION

- Install the cooling fan to the radiator.

#### ☑ Cooling fan motor mounting bolt:

**8 N·m (0.8 kgf-m, 6.0 lb-ft)**

- Connect the cooling fan thermo-switch coupler ①.
- Install the radiator.
- Route the radiator hoses properly. (☞9-24)
- Pour engine coolant. (☞2-18)
- Bleed the air from the cooling circuit. (☞2-19)
- Install the cowling. (☞7-8)

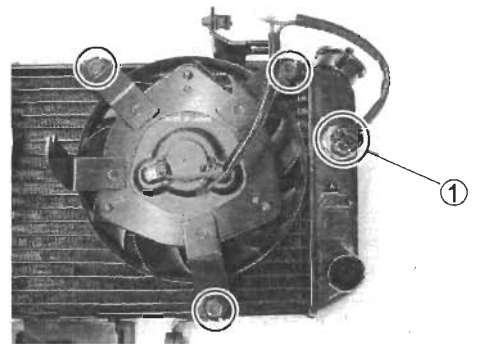

## COOLING FAN THERMO-SWITCH

### REMOVAL

- Remove the cowling. (☞ 7-5)
- Drain the engine coolant. (☞ 2-18)
- Disconnect the cooling fan thermo-switch lead wire coupler ①.
- Remove the cooling fan thermo-switch ②.

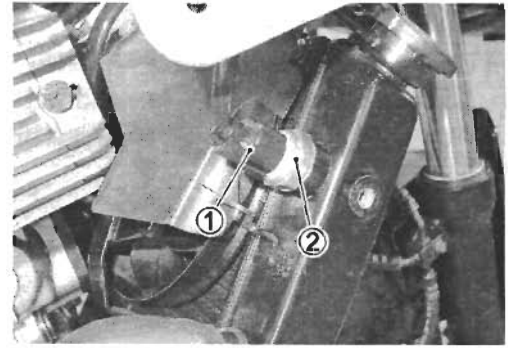

### INSPECTION

- Check the thermo-switch closing or opening temperatures by testing it at the bench as shown in the figure. Connect the thermo-switch ① to a circuit tester and place it in the OIL contained in a pan, which is placed on a stove.
- Heat the oil to raise its temperature slowly and read the column thermometer ② when the switch closes or opens.

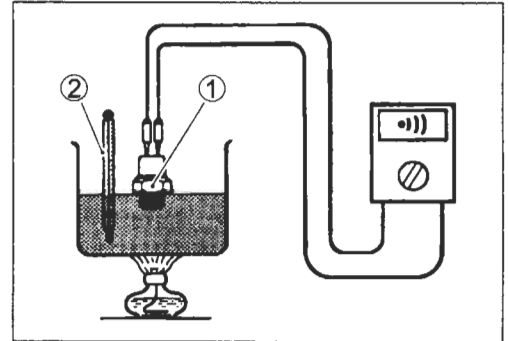

**TOOL** 09900-25008: Multi circuit tester set

**Tester knob indication: Continuity test (•••)**

**DATA** Cooling fan thermo-switch operating temperature  
 Standard (OFF→ON): Approx. 98 °C (208 °F)  
 (ON→OFF): Approx. 92 °C (198 °F)

### CAUTION

- \* Take special care when handling the thermo-switch. It may cause damage if it gets a sharp impact.
- \* Do not contact the cooling fan thermo-switch ① and the column thermometer ② with a pan.

### INSTALLATION

- Install a new O-ring ① and apply engine coolant to the O-ring.
  - Tighten the cooling fan thermo-switch to the specified torque.
- 🔧 Cooling fan thermo-switch: 17 N·m (1.7 kgf-m, 12.5 lb-ft)**
- Pour engine coolant. (☞ 2-18)
  - Bleed air from the cooling circuit. (☞ 2-19)
  - Install the cowling. (☞ 7-8)

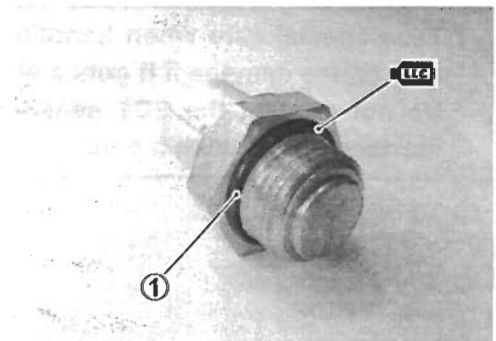

## ECT SENSOR

### REMOVAL

- Drain the engine coolant. (☞ 2-18)
- Disconnect the ECT sensor lead wire coupler.
- Place a rag under the ECT sensor and remove the ECT sensor ①.

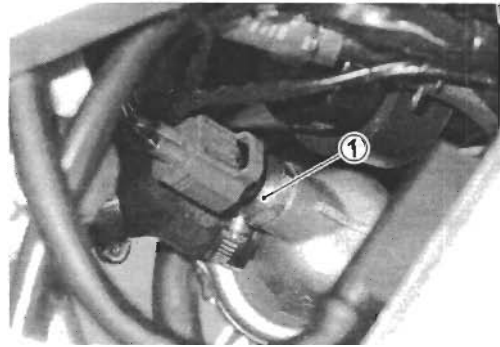

### INSPECTION

- Check the ECT sensor by testing it at the bench as shown in the figure. Connect the ECT sensor ① to a circuit tester and place it in the WATER contained in a pan, which is placed on a stove.
- Heat the water to raise its temperature slowly and read the column thermometer ② and the ohmmeter.
- If the ECT sensor ohmic value does not change in the proportion indicated, replace it with a new one.

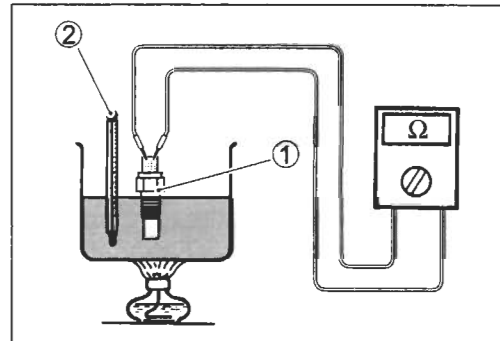

#### **DATA** Temperature sensor specification

Temperature	Standard resistance
20 °C (68 °F)	Approx. 2.45 kΩ
40 °C (104 °F)	Approx. 1.148 kΩ
60 °C (140 °F)	Approx. 0.587 kΩ
80 °C (176 °F)	Approx. 0.322 kΩ

If the resistance noted to show infinity or too much different resistance value, replace the ECT sensor with a new one.

#### **CAUTION**

- \* Take special care when handling the ECT sensor. It may cause damage if it gets a sharp impact.
- \* Do not contact the ECT sensor ① and the column thermometer ② with a pan.



## INSTALLATION

- Install a new sealing washer ①.
- Tighten the ECT sensor to the specified torque.

 ECT sensor: 19 N·m (1.9 kgf·m, 13.5 lb-ft)

### CAUTION

**Take special care when handling the ECT sensor. It may cause damage if it gets a sharp impact.**

- Pour engine coolant. ( 2-18)
- Bleed air from the cooling circuit. ( 2-19)

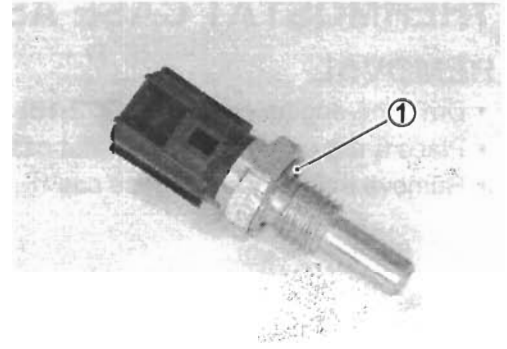



## THERMOSTAT CASE ASSEMBLY

### REMOVAL

- Drain the engine coolant. (☞ 2-18)
- Place a rag under the thermostat case.
- Remove the thermostat case cap ①.

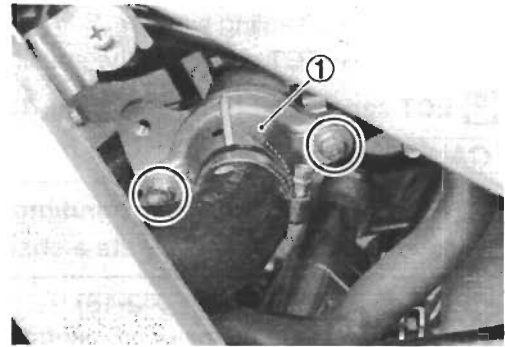

- Remove the thermostat ②.

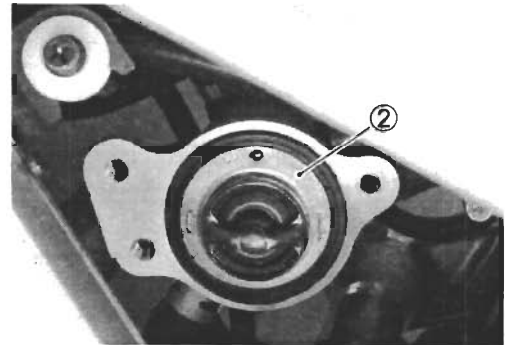

### INSPECTION

Inspect the thermostat pellet for signs of cracking.

Test the thermostat at the bench for control action, in the following manner.

- Pass a string between flange, as shown in the photograph.
- Immerse the thermostat in the WATER contained in a beaker, as shown in the illustration. Note that the immersed thermostat is in suspension. Heat the water by placing the beaker on a stove ① and observe the rising temperature on a thermometer ②.
- Read the thermometer just when opening the thermostat. This reading, which is the temperature level at which the thermostat valve begins to open, should be within the standard value.

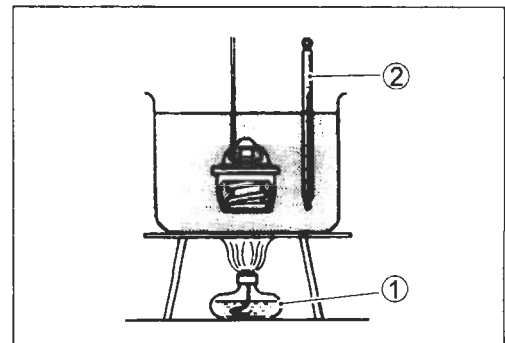
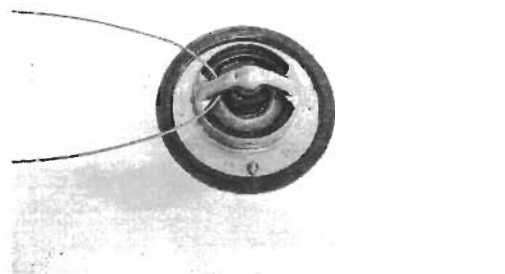

**DATA** Thermostat valve opening temperature  
Standard: Approx. 88 °C (190 °F)

- Keep on heating the water to raise its temperature.
- Just when the water temperature reaches specified value, the thermostat valve should have lifted by at least 8.0 mm (0.31 in).

**DATA** **Thermostat valve lift**

**Standard: Over 8.0 mm at 100 °C (Over 0.31 in at 212 °F)**

- A thermostat failing to satisfy either of the two requirements, start-to-open temperature and valve lift, must be replaced.

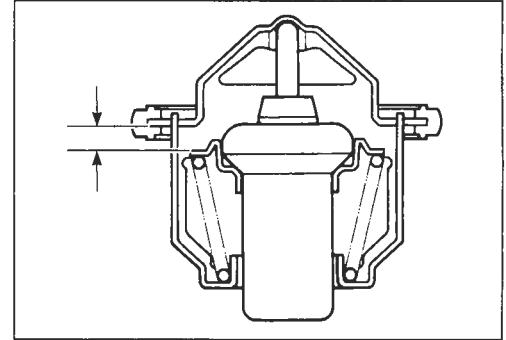

## INSTALLATION

- Apply engine coolant to the rubber seal on the thermostat.
- Install the thermostat.

**NOTE:**

The jiggle valve (A) of the thermostat faces upside.

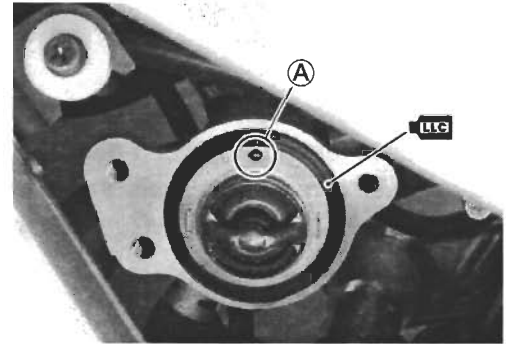

- Install the thermostat case cap (1).

**NOTE:**

The rib (A) of the thermostat case cap should be faced upward.

- Tighten the thermostat case bolts to the specified torque.

**Thermostat case bolt: 10 N·m (1.0 kgf-m, 7.0 lb-ft)**

- Pour engine coolant. (☞ 2-18)
- Bleed air from the cooling circuit. (☞ 2-19)

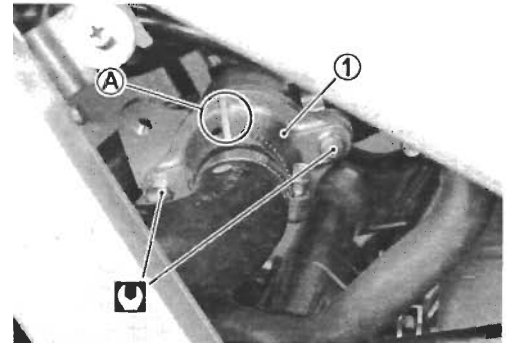

## WATER PUMP

### REMOVAL AND DISASSEMBLY

- Drain the engine coolant. (☞ 2-18)
- Drain the engine oil. (☞ 2-13)
- Disconnect the water hoses ①, ②.
- Remove the water pump case and clutch cover. (☞ 3-27)

#### NOTE:

Before draining engine oil and engine coolant, inspect engine oil and coolant leakage between the water pump and clutch cover. If engine oil is leaking, visually inspect the oil seal and O-ring. If engine coolant is leaking, visually inspect the mechanical seal and seal ring. (☞ 6-16)

- Remove the snap ring and water pump driven gear ③.

- Remove the pin ④ and washer ⑤.

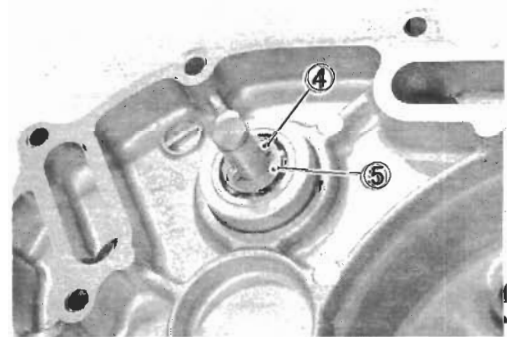
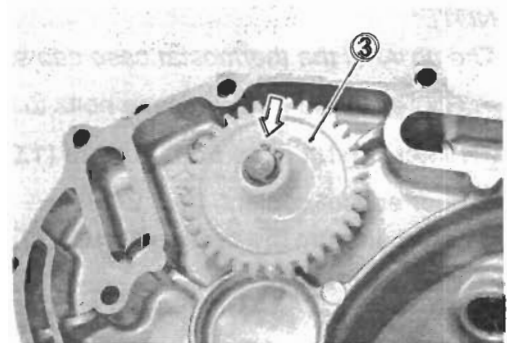
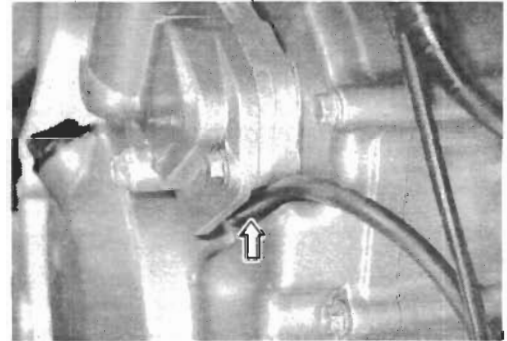
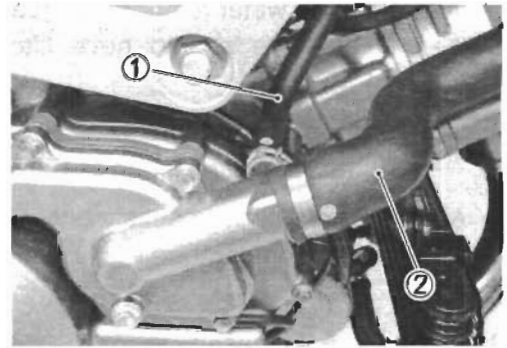

- Remove the water pump ⑥ from the clutch cover.

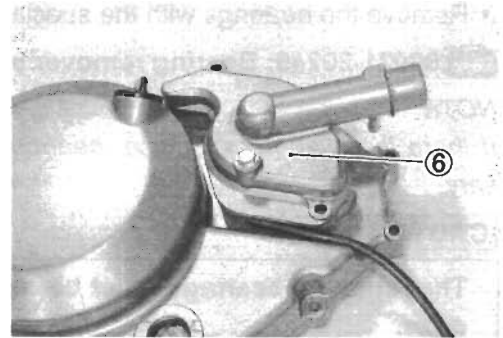

- Remove the screws and separate the water pump.
- Remove the O-rings ⑦.

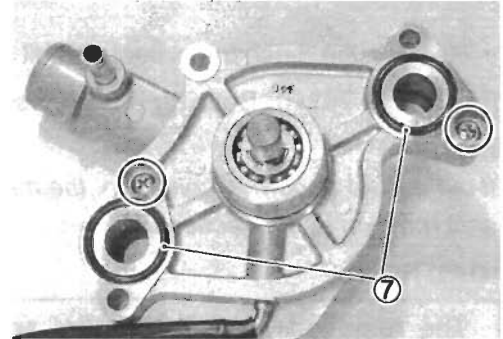

- Remove the E-ring from the impeller shaft.
- Remove the impeller from the other side.

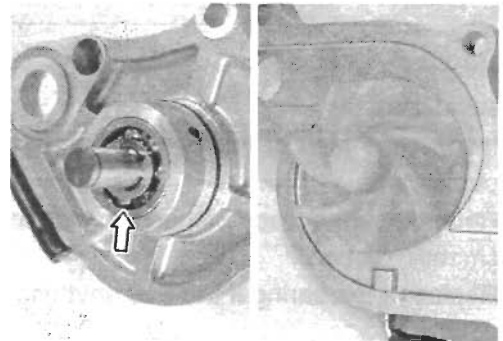

- Remove the mechanical seal ring ⑤ and rubber seal ⑥ from the impeller.

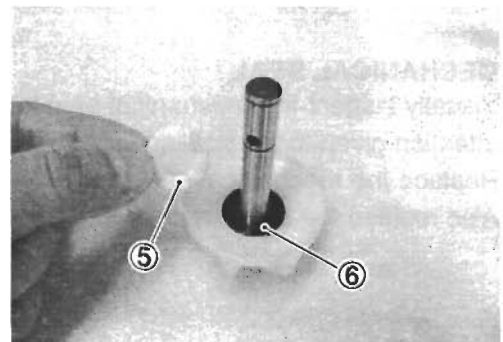

- Remove the bearings with the special tool.

**TOOL** 09921-20240: Bearing remover set (10 mm)

**NOTE:**

*If there is no abnormal noise, bearings removal is not necessary.*

**CAUTION**

**The removed bearings must be replaced with the new ones.**

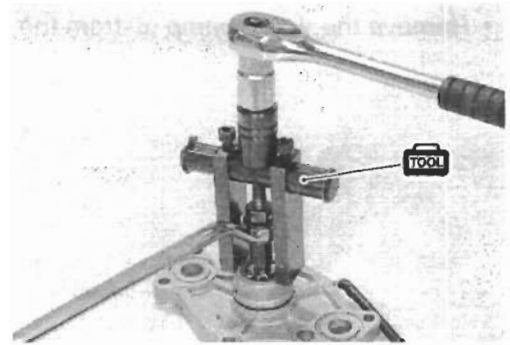

- Remove the mechanical seal and oil seal with the special tool.

**TOOL** 09913-70210: Bearing installer set ( $\phi$  20 mm)

**NOTE:**

*If there is no abnormal condition, the mechanical seal and the oil seal removal is not necessary.*

**CAUTION**

**The removed mechanical seal and oil seal must be replaced with a new one.**

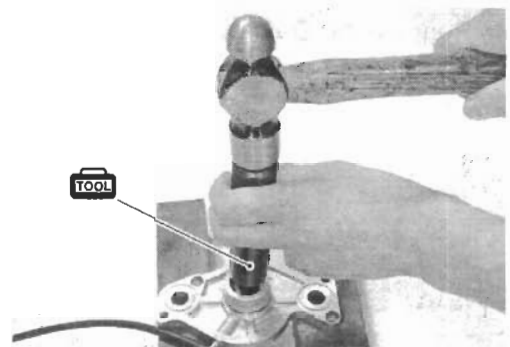

## INSPECTION

### BEARING

Inspect the play of the bearing by hand while it is in the water pump case.

Rotate the inner race by hand to inspect for abnormal noise and smooth rotation.

Replace the bearing if there is anything unusual.

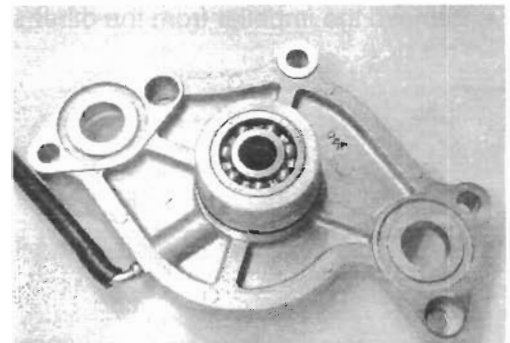

### MECHANICAL SEAL

Visually inspect the mechanical seal for damage, with particular attention given to the sealing face.

Replace the mechanical seal that shows indications of leakage. Also replace the seal ring if necessary.

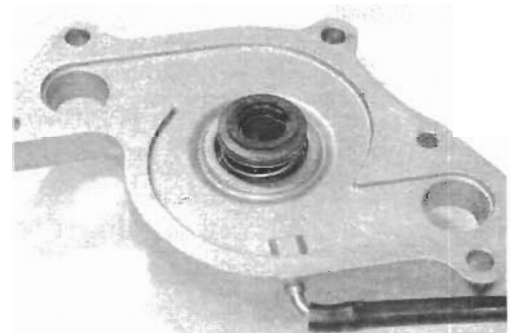

**OIL SEAL**

Visually inspect the oil seal for damage, with particular attention given to the lip.

Replace the oil seal that shows indications of oil leakage.

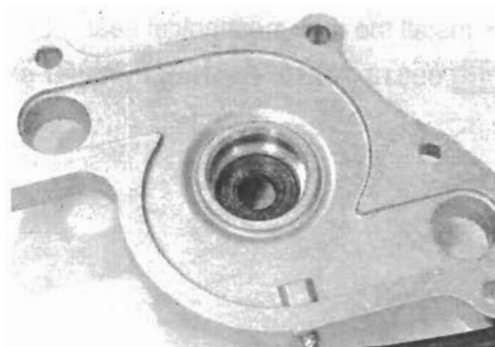
**BEARING CASE**

Visually inspect the bearing case for damage.

Replace the water pump body if necessary.

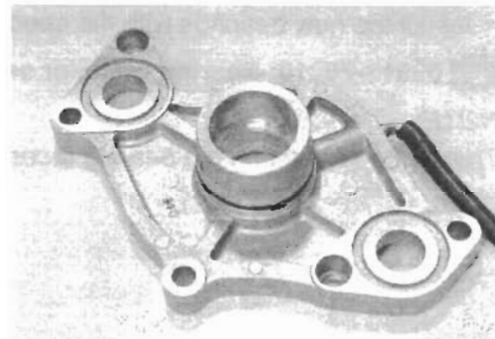
**REASSEMBLY AND INSTALLATION**

- Install the oil seal with the special tool.

**TOOL** 09913-70210: Bearing installer set ( $\phi$  22 mm)

**NOTE:**

*The stamped mark on the oil seal faces impeller side.*

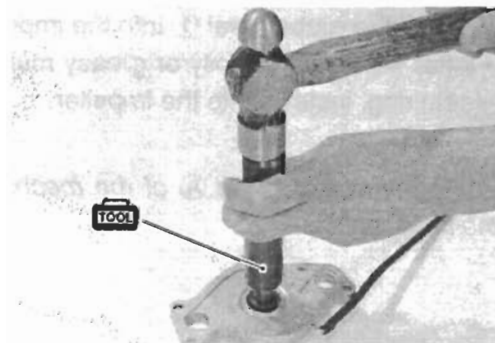

- Apply a small quantity of the SUZUKI SUPER GREASE to the oil seal lip.

**AH** 99000-25030: SUZUKI SUPER GREASE "A" (USA)

99000-25010: SUZUKI SUPER GREASE "A" (Others)

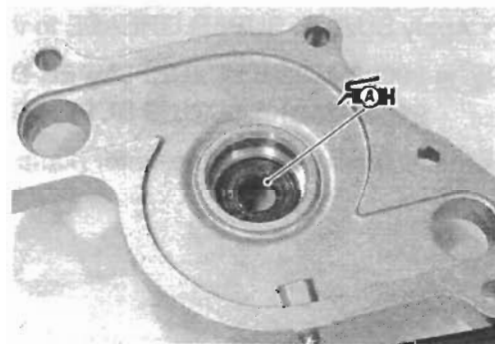

- Install the new mechanical seal with the special tool.

 **09913-70210: Bearing installer set ( $\phi$  25 mm)**

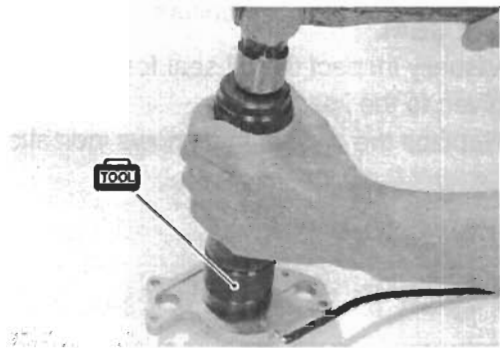

- Install the new bearings with the special tool.

 **09913-70210: Bearing installer set ( $\phi$  25 mm)**

**NOTE:**

*The stamped mark on the bearing faces to the crankcase side.*

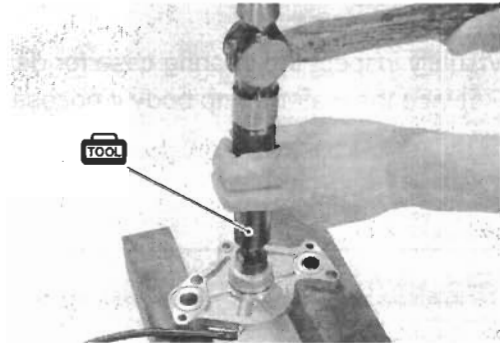

- Install the rubber seal ① into the impeller.
- After wiping off the oily or greasy matter from the mechanical seal ring, install it into the impeller.

**NOTE:**

*The paint marked side ① of the mechanical seal ring faces to the impeller.*

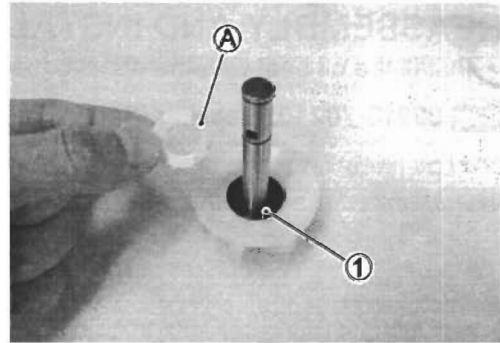

- Apply SUZUKI SUPER GREASE to the impeller shaft.

 **99000-25030: SUZUKI SUPER GREASE "A" (USA)**  
**99000-25010: SUZUKI SUPER GREASE "A" (Others)**

- Install the impeller to the water pump body.

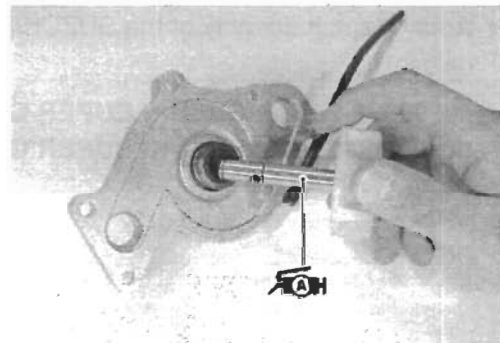

- Fix the impeller shaft with the E-ring ②.
- Apply SUZUKI SUPER GREASE to the O-rings.

 **99000-25030: SUZUKI SUPER GREASE "A" (USA)**  
**99000-25010: SUZUKI SUPER GREASE "A" (Others)**

- Install new O-rings ③.
- Fill the bearing with engine oil until engine oil comes out from the hole of the bearing housing.

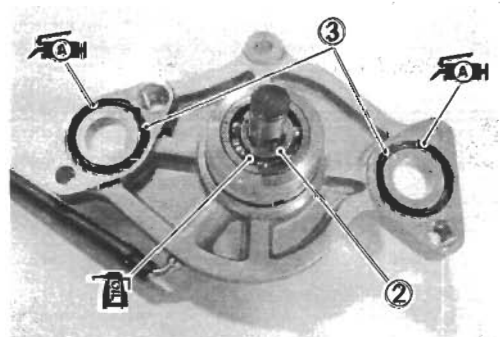

- Apply engine coolant to the O-ring ④.
- Install a new O-ring.

**CAUTION**

**Use a new O-ring to prevent engine coolant leakage.**

- Connect the water hoses.
- Pour engine coolant. (☞ 2-18)
- Pour engine oil. (☞ 2-14)

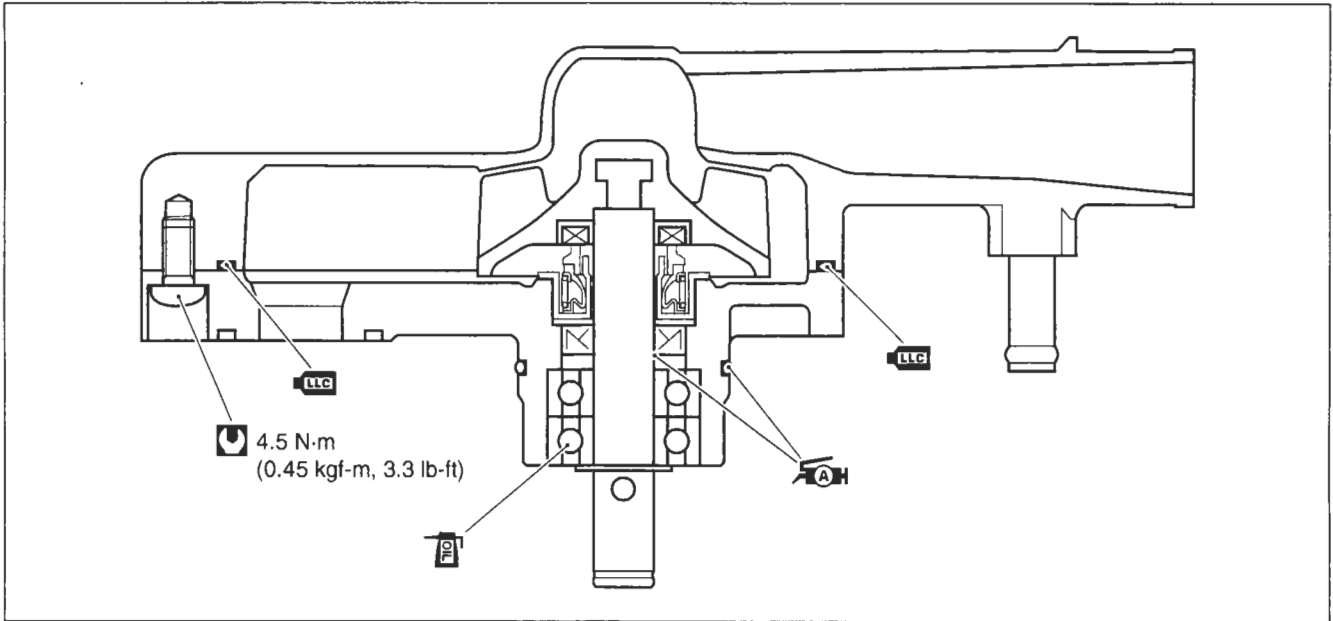
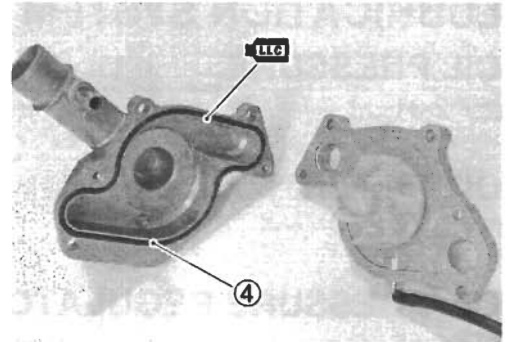



## **LUBRICATION SYSTEM**

### **OIL PRESSURE**

 2-31

### **OIL FILTER**

 2-14

### **OIL PRESSURE REGULATOR**

 3-57

### **OIL STRAINER**

 3-58

### **OIL JET**

 3-49, -59, -60 and -96

### **OIL PUMP**

 3-81 and -89

### **OIL PRESSURE SWITCH**

 3-58 and 8-34



## OIL COOLER

### REMOVAL

- Drain the engine oil. (☞ 2-13)
- Disconnect the oil cooler hoses.

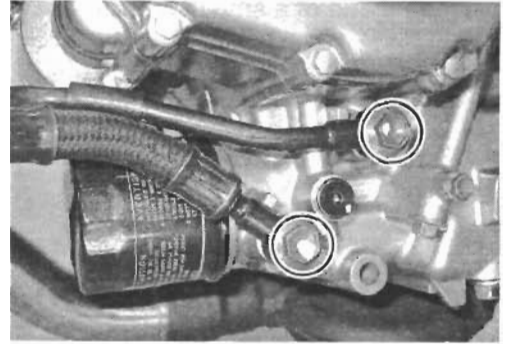

- Remove the oil cooler.

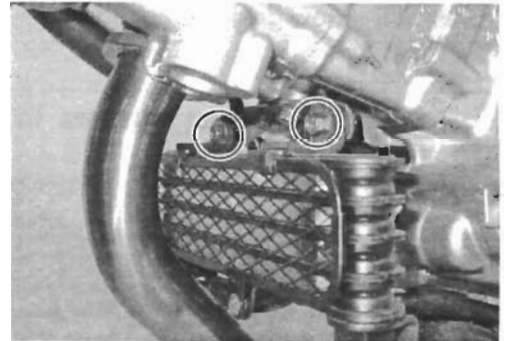

- Remove the oil cooler fin guard net ①.
- Remove the oil hoses ②.

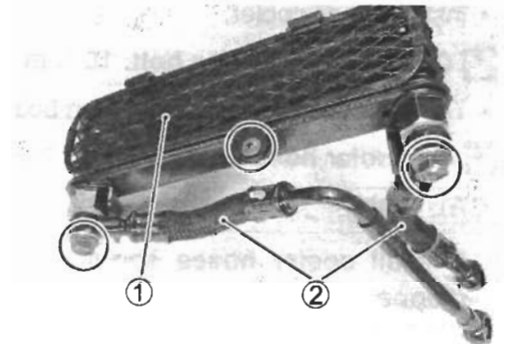

### INSPECTION AND CLEANING

Inspect the oil cooler and hose joints for oil leakage. If any defect are found, replace the oil cooler and oil hoses with the new ones.

Road dirt or trash stuck to the fins must be removed.

Use of compressed air is recommended for this cleaning.

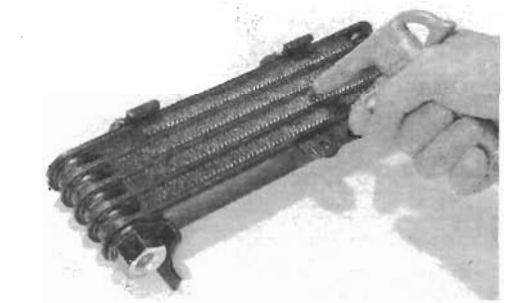

Fins bent down or dented can be repaired by straightening them with the blade of a small screwdriver.

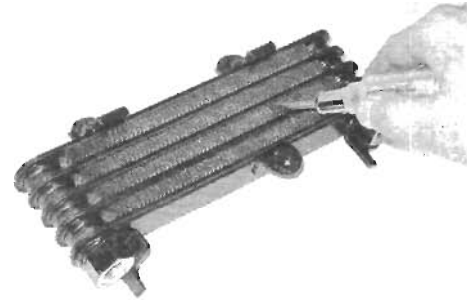

## INSTALLATION

- Install the new gasket washers ①.

### CAUTION

Use the new gasket washers to prevent engine oil leakage.

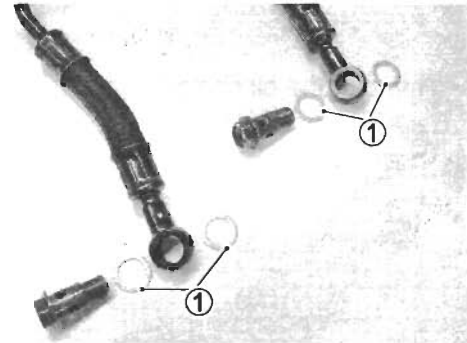

- Connect the oil hoses.
- Install the oil cooler.

**Oil cooler mounting bolt: 10 N-m (1.0 kgf-m, 7.0 lb-ft)**

- Tighten the oil cooler hose union bolts to the specified torque.

**Oil cooler hose union bolt: 23 N-m (2.3 kgf-m, 16.5 lb-ft)**

### CAUTION

The oil cooler hoses should be contacted with the stoppers **A**.

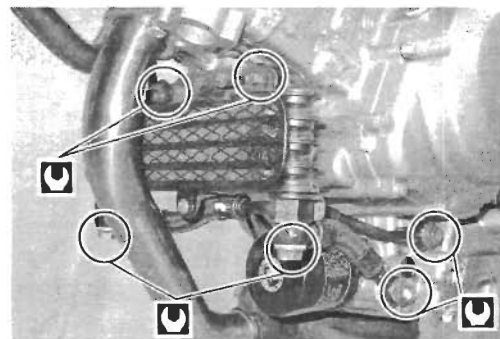
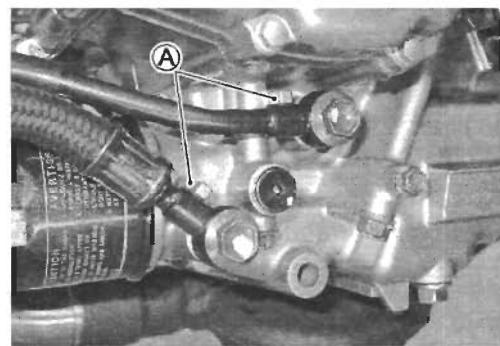
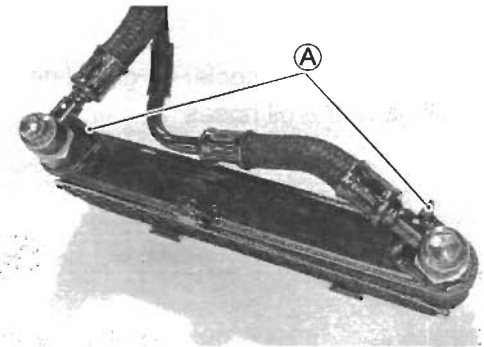

# ENGINE LUBRICATION FLOW CHART

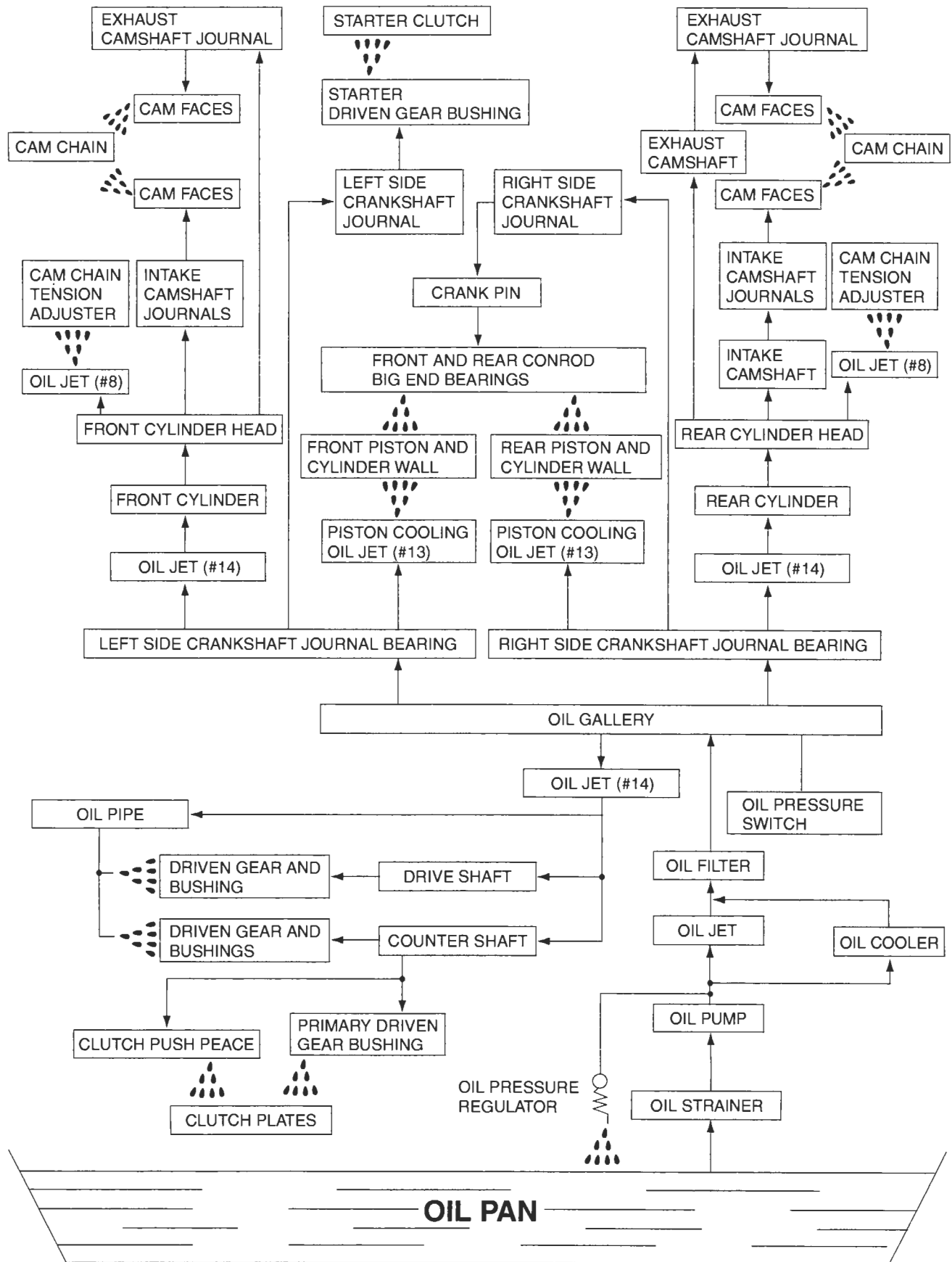

# ENGINE LUBRICATION CIRCUIT

## FRONT CYLINDER

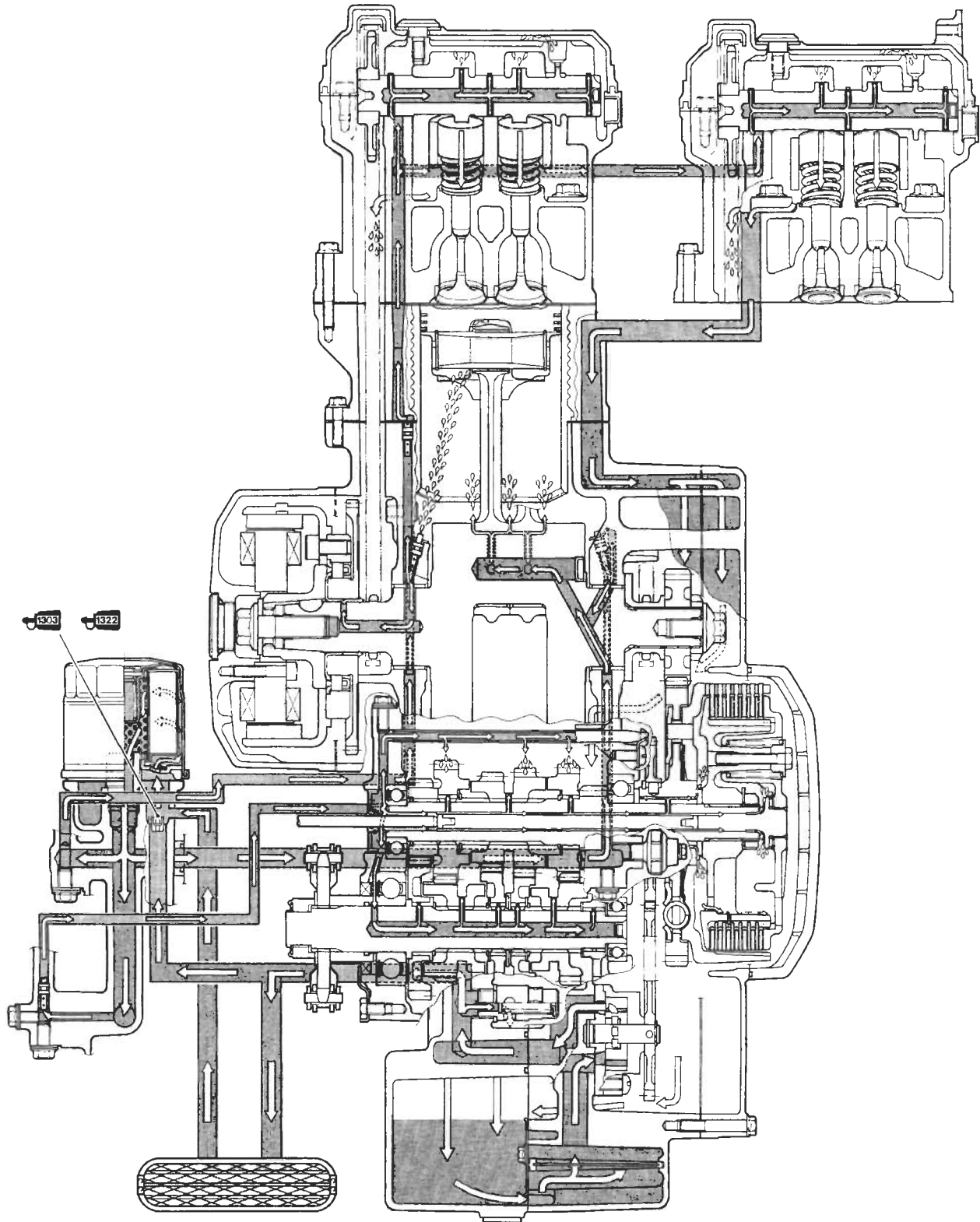

REAR CYLINDER

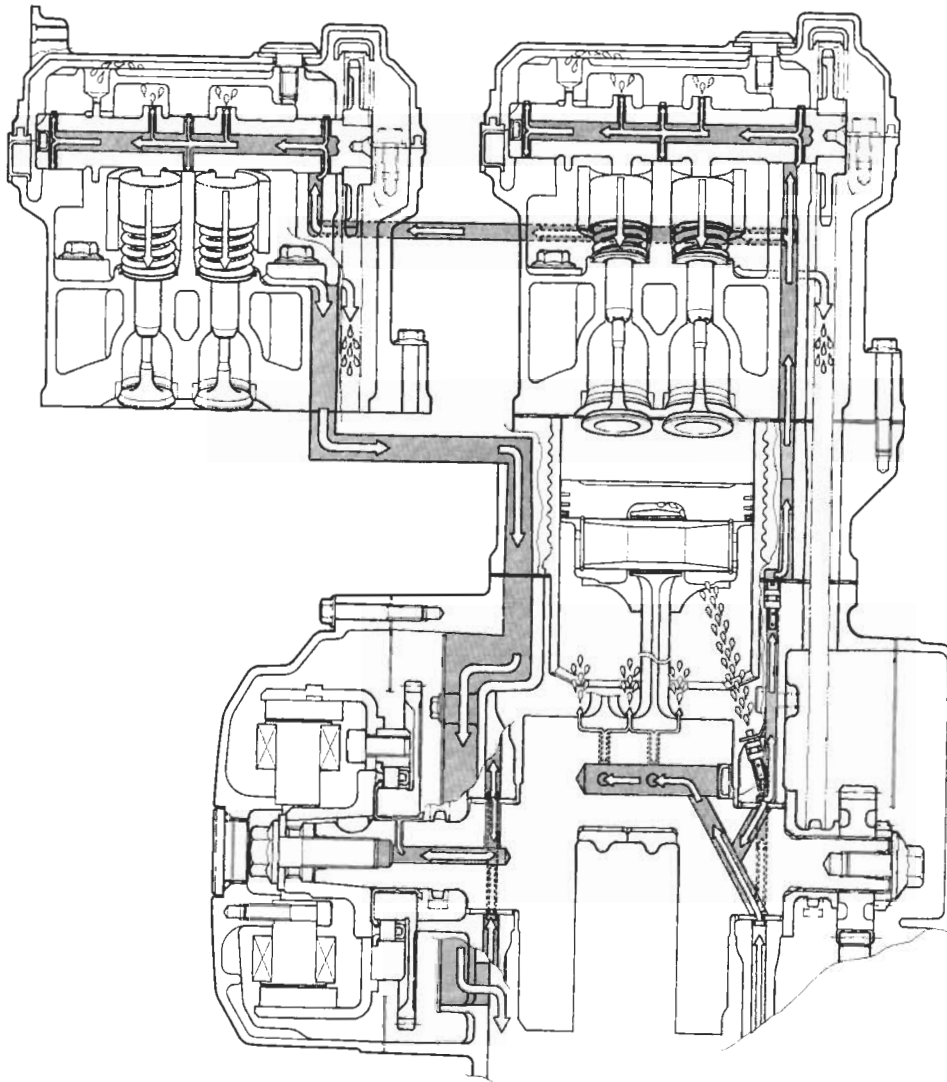

# CHASSIS

## CONTENTS

<b>EXTERIOR PARTS</b> .....	7- 2
<b>CONSTRUCTION</b> .....	7- 2
<b>REMOVAL</b> .....	7- 4
<b>INSTALLATION</b> .....	7- 8
<b>FRONT WHEEL</b> .....	7- 9
<b>CONSTRUCTION</b> .....	7- 9
<b>REMOVAL</b> .....	7-10
<b>INSPECTION AND DISASSEMBLY</b> .....	7-10
<b>REASSEMBLY AND REMOUNTING</b> .....	7-12
<b>FRONT FORK</b> .....	7-16
<b>CONSTRUCTION</b> .....	7-16
<b>REMOVAL AND DISASSEMBLY</b> .....	7-17
<b>INSPECTION</b> .....	7-20
<b>REASSEMBLY AND REMOUNTING</b> .....	7-21
<b>SUSPENSION SETTING</b> .....	7-25
<b>STEERING AND HANDLEBAR</b> .....	7-26
<b>CONSTRUCTION</b> .....	7-26
<b>REMOVAL</b> .....	7-27
<b>INSPECTION AND DISASSEMBLY</b> .....	7-30
<b>REASSEMBLY AND REMOUNTING</b> .....	7-31
<b>STEERING TENSION ADJUSTMENT</b> .....	7-34
<b>REAR WHEEL</b> .....	7-35
<b>CONSTRUCTION</b> .....	7-35
<b>REMOVAL</b> .....	7-36
<b>INSPECTION AND DISASSEMBLY</b> .....	7-37
<b>REASSEMBLY AND REMOUNTING</b> .....	7-40
<b>REAR SHOCK ABSORBER</b> .....	7-44
<b>CONSTRUCTION</b> .....	7-44
<b>REMOVAL</b> .....	7-45
<b>INSPECTION</b> .....	7-46
<b>REAR SHOCK ABSORBER DISPOSAL</b> .....	7-46
<b>REMOUNTING</b> .....	7-47
<b>SUSPENSION SETTING</b> .....	7-48
<b>REAR SWINGARM</b> .....	7-49
<b>CONSTRUCTION</b> .....	7-49
<b>REMOVAL</b> .....	7-50
<b>INSPECTION AND DISASSEMBLY</b> .....	7-51
<b>REASSEMBLY</b> .....	7-54

<b>REMOUNTING</b> .....	7-56
<b>FINAL INSPECTION AND ADJUSTMENT</b> .....	7-57
<b>FRONT BRAKE</b> .....	7-58
<b>CONSTRUCTION</b> .....	7-58
<b>BRAKE PAD REPLACEMENT</b> .....	7-59
<b>BRAKE FLUID REPLACEMENT</b> .....	7-60
<b>CALIPER REMOVAL AND DISASSEMBLY</b> .....	7-61
<b>CALIPER INSPECTION</b> .....	7-62
<b>CALIPER REASSEMBLY AND REMOUNTING</b> .....	7-63
<b>BRAKE DISC INSPECTION</b> .....	7-65
<b>MASTER CYLINDER REMOVAL AND DISASSEMBLY</b> .....	7-65
<b>MASTER CYLINDER INSPECTION</b> .....	7-66
<b>MASTER CYLINDER REASSEMBLY AND REMOUNTING</b> .....	7-67
<b>REAR BRAKE</b> .....	7-68
<b>CONSTRUCTION</b> .....	7-68
<b>BRAKE PAD REPLACEMENT</b> .....	7-69
<b>BRAKE FLUID REPLACEMENT</b> .....	7-71
<b>CALIPER REMOVAL AND DISASSEMBLY</b> .....	7-71
<b>CALIPER INSPECTION</b> .....	7-73
<b>BRAKE DISC INSPECTION</b> .....	7-74
<b>CALIPER REASSEMBLY AND REMOUNTING</b> .....	7-74
<b>MASTER CYLINDER REMOVAL AND DISASSEMBLY</b> .....	7-75
<b>MASTER CYLINDER INSPECTION</b> .....	7-77
<b>MASTER CYLINDER REASSEMBLY AND REMOUNTING</b> .....	7-77
<b>TIRE AND WHEEL</b> .....	7-79
<b>TIRE REMOVAL</b> .....	7-79
<b>INSPECTION</b> .....	7-79
<b>VALVE INSTALLATION</b> .....	7-80
<b>TIRE INSTALLATION</b> .....	7-81
<b>DRIVE CHAIN</b> .....	7-83
<b>DRIVE CHAIN CUTTING</b> .....	7-83
<b>DRIVE CHAIN CONNECTING</b> .....	7-84



# EXTERIOR PARTS CONSTRUCTION

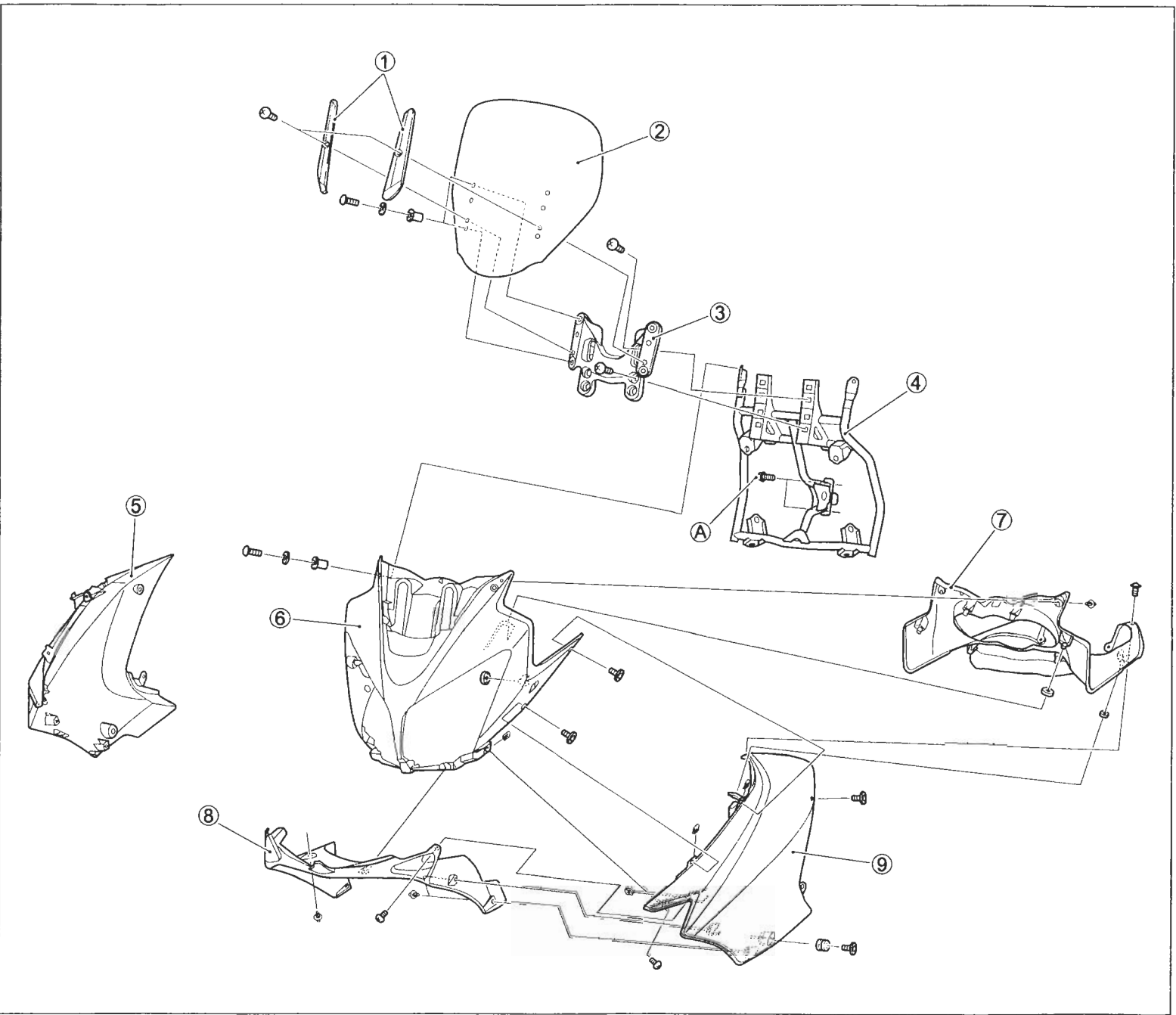

①	Wind screen cover	⑥	Cowling body
②	Wind screen	⑦	Combination meter panel
③	Wind screen brace	⑧	Cowling inner cover
④	Cowling brace	⑨	Left cowling
⑤	Right cowling	Ⓐ	Cowling brace mounting bolt



ITEM	N·m	kgf·m	lb·ft
Ⓐ	35	3.5	25.5

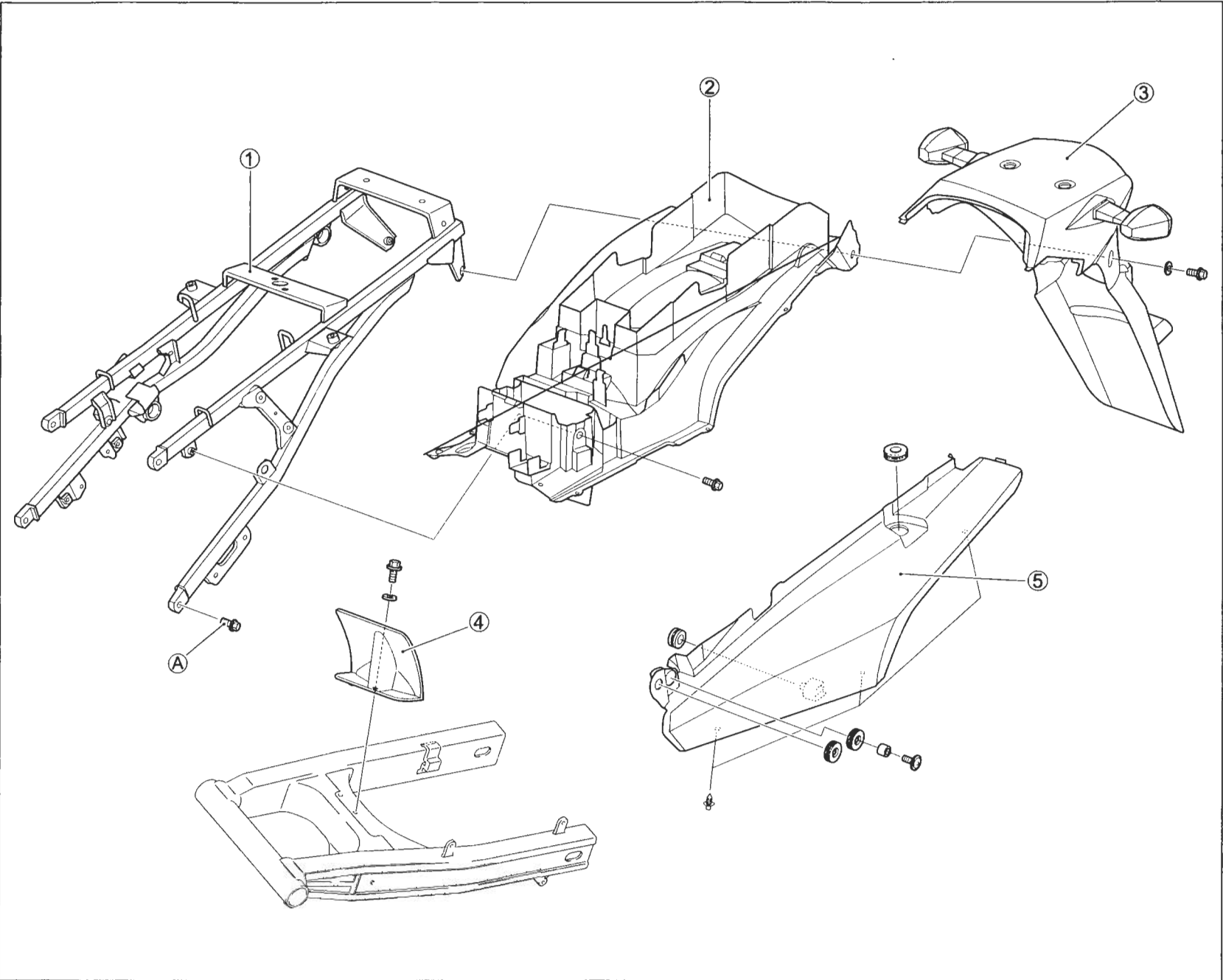

①	Seat rail	④	Mud guard
②	Rear fender No. 1	⑤	Frame cover
③	Rear fender No. 2	Ⓐ	Seat rail mounting bolt

ITEM	N·m	kgf·m	lb·ft
Ⓐ	50	5.0	36.0

## REMOVAL SEAT

- Remove the seat with the ignition key ①.

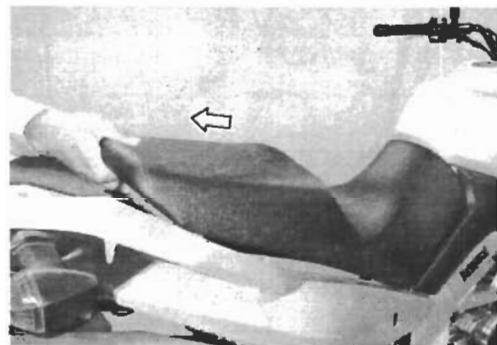
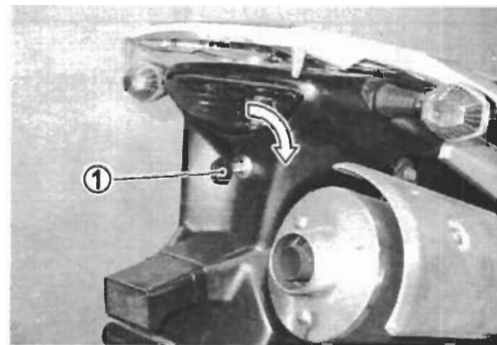

## FUEL TANK SIDE COVER

- Remove the seat. (☞ 7-4)
- Remove the fuel tank side covers ①.

### NOTE:

“☆” indicates hook location.

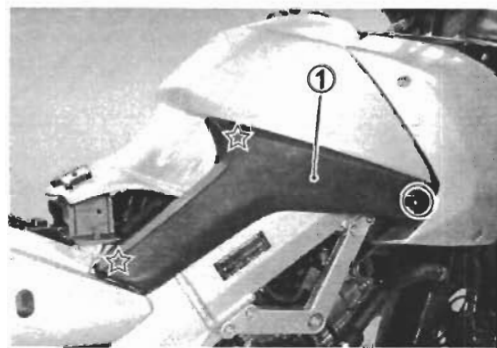

## CARRIER

- Remove the seat. (☞ 7-4)
- Remove the carrier ①.

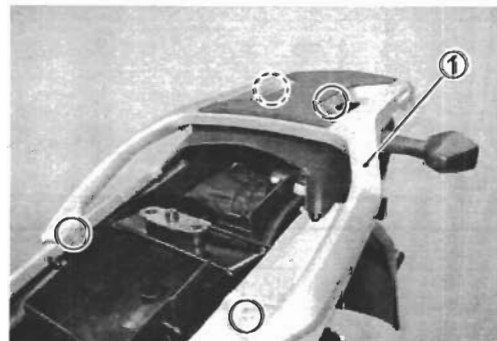

**FRAME COVER**

- Remove the seat. (☞7-4)
- Remove the carrier. (☞7-4)
- Remove the fuel tank side cover. (☞7-4)
- Remove the frame covers ①.

**NOTE:**

"☆" indicates hook location.

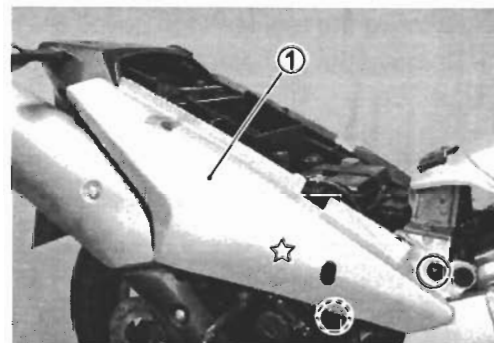
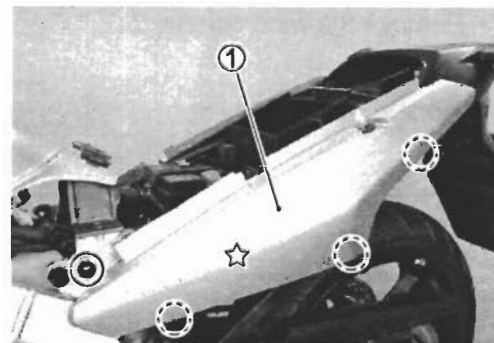
**REAR FENDER**

- Remove the seat. (☞7-4)
- Remove the carrier. (☞7-4)
- Remove the bolts ①.

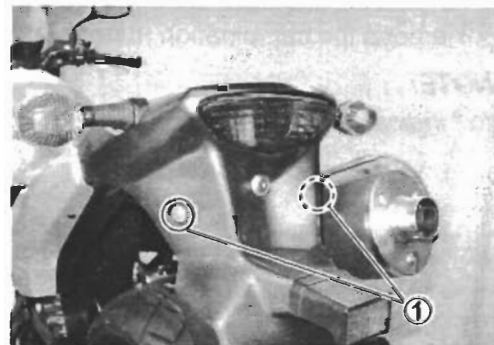

- Disconnect the brake light/taillight lead wire coupler ② and seat lock cable ③.
- Remove the rear fender.

**COWLING AND COWLING BRACE**

- Remove the seat. (☞7-4)
- Disconnect the battery ⊖ lead wire.
- Remove the wind screen covers ①.

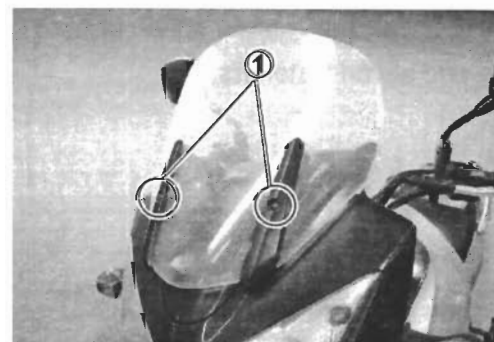

- Remove the wind screen ②.

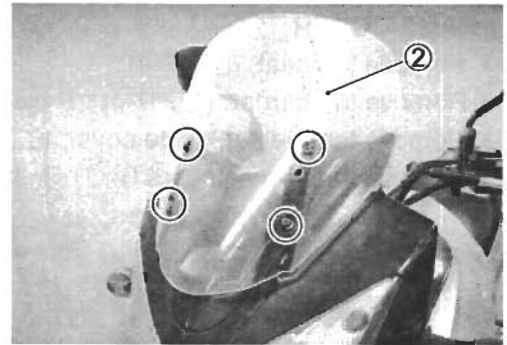

- Remove the fuel tank top cover ③.
- Remove the combination meter panel mounting screws ④.

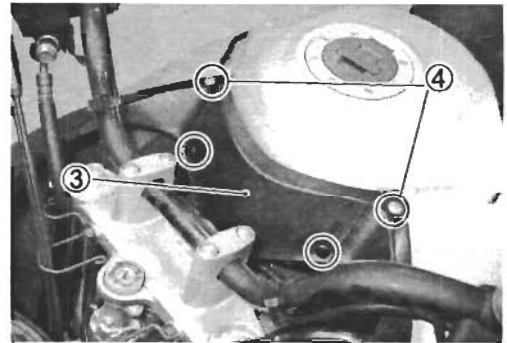

- Remove the combination meter panel ⑤.

NOTE:

“☆” indicates hook location.

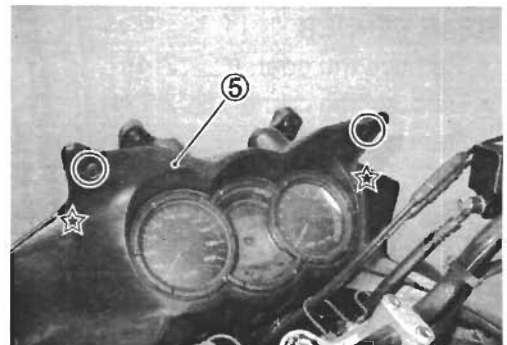

- Disconnect the speedometer lead wire coupler ⑥.

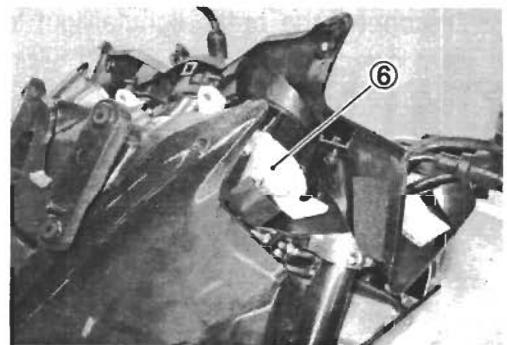

- Remove the cowling inner cover ⑦ by removing two screws and seven fasteners.

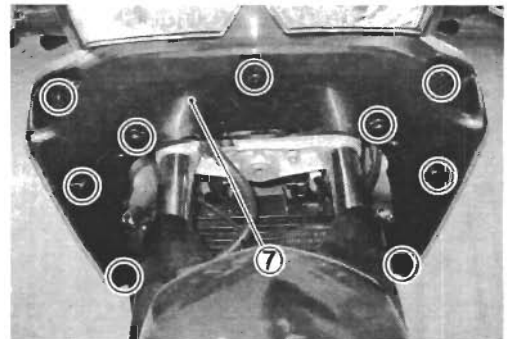

- Remove the left cowling ⑧.

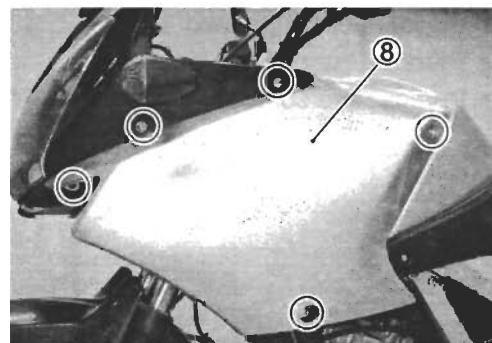

- Remove the right cowling ⑨.

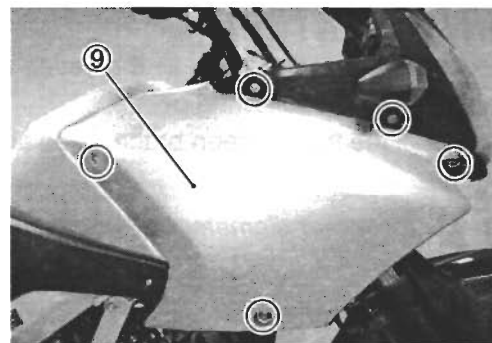

- Remove the wind screen brace ⑩.

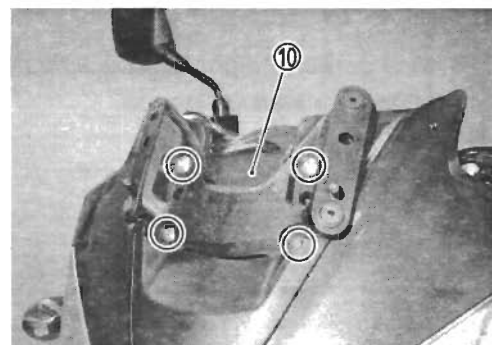

- Disconnect the turn signal light lead wire couplers ⑪.
- Remove the screws ⑫.

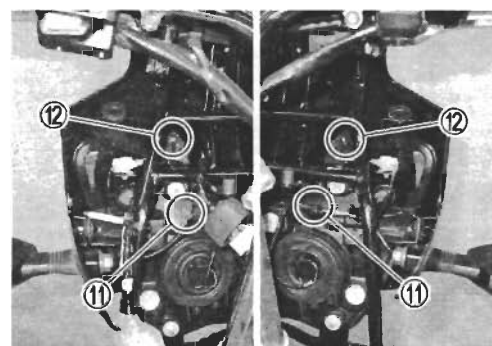

- Remove the cowling body ⑬.

**NOTE:**

“☆” indicates hook location.

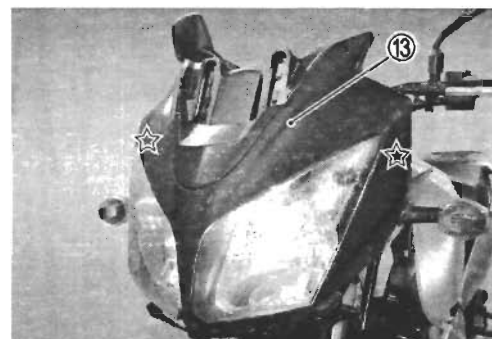

- Disconnect the coupler ⑭.
- Remove the cowling brace ⑮.
- Remove the combination meter. (☞ 8-29)

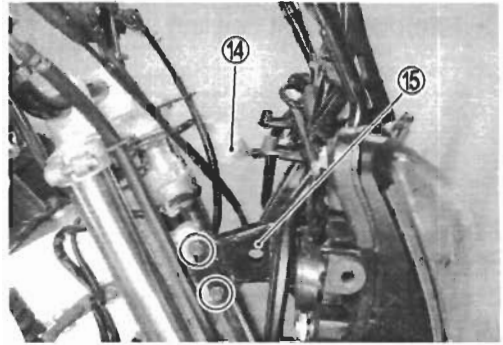

## INSTALLATION

Install the exterior parts in the reverse order of removal. Pay attention to the following points:

- Install the wind screen brace ① as shown in the photograph.

**NOTE:**

*Install the larger diameter bolts on the wind screen brace attaching section ①.*

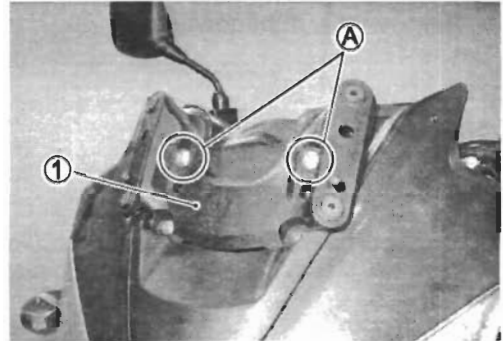

**NOTE:**

*The wind screen height can be adjusted by changing the wind screen brace installed position.*

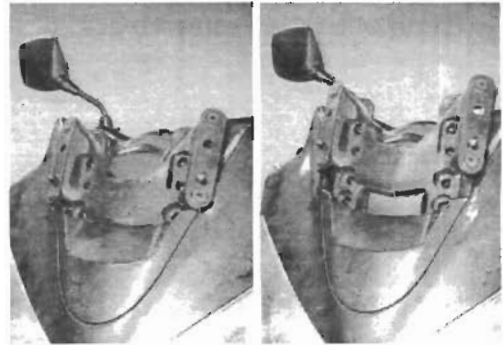

# FRONT WHEEL CONSTRUCTION

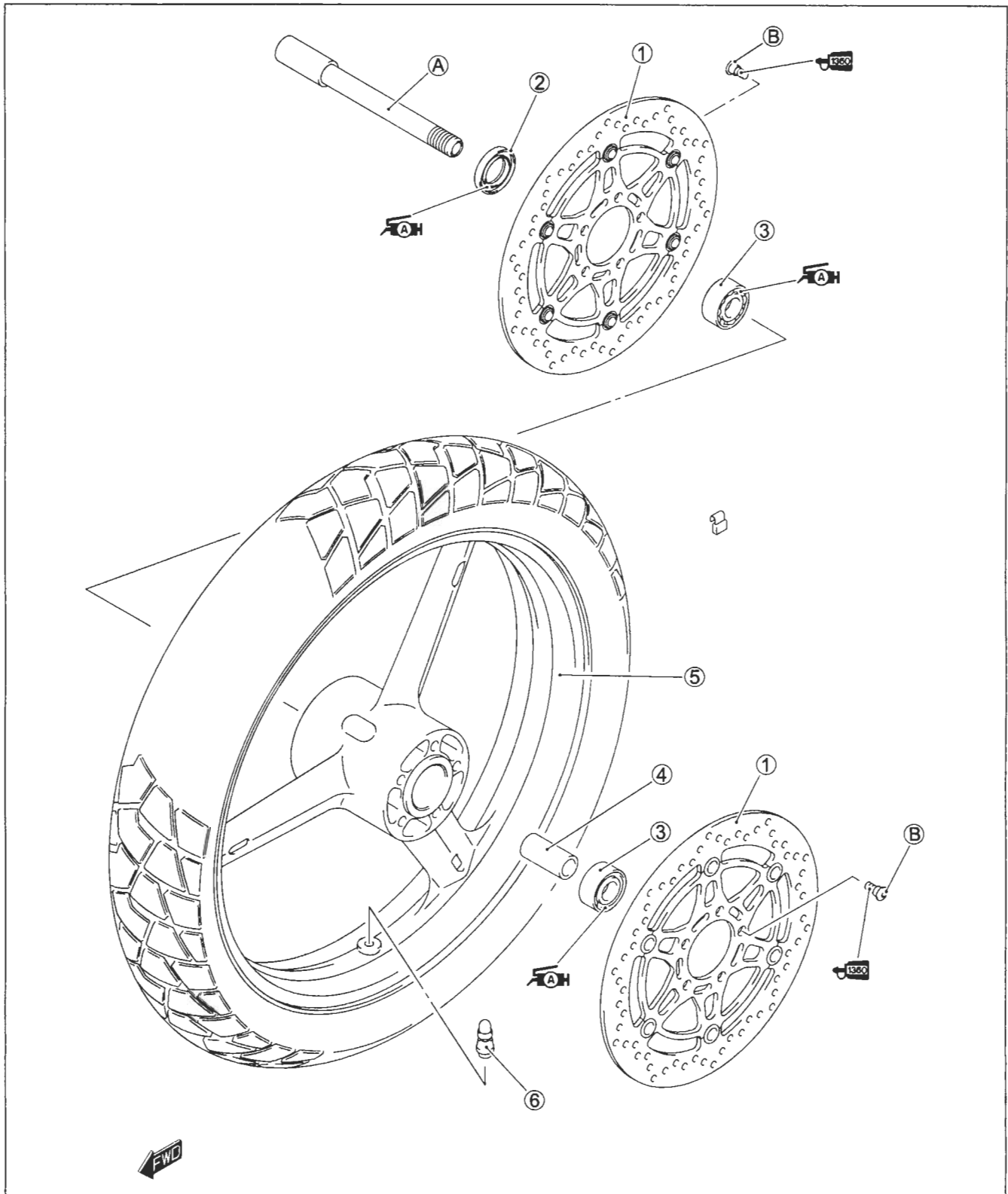

①	Brake disc	⑤	Front wheel
②	Dust seal	⑥	Tire valve
③	Bearing	A	Front axle
④	Center spacer	B	Brake disc bolt

ITEM	N-m	kgf-m	lb-ft
A	65	6.5	47.0
B	23	2.3	16.5



## REMOVAL

- Remove the right and left brake calipers. (☞ 7-59)
- Loosen the axle pinch bolt ① on the right front fork leg.

### CAUTION

Do not operate the brake lever while removing the calipers.

- Slightly loosen the front axle with the special tool.

 09900-18710: Hexagon bit 12 mm

- Raise the front wheel off the ground and support the motorcycle with a jack or a wooden block.
- Remove the front axle ② and the front wheel.

### NOTE:

After removing the front wheel, fit the calipers temporarily to the original positions.

## INSPECTION AND DISASSEMBLY

### TIRE (☞ 7-79)

### BRAKE DISC (☞ 7-65)

- Remove the brake discs.

### DUST SEAL

- Inspect the dust seal lip for wear or damage. If any damages are found, replace the dust seal with a new one.

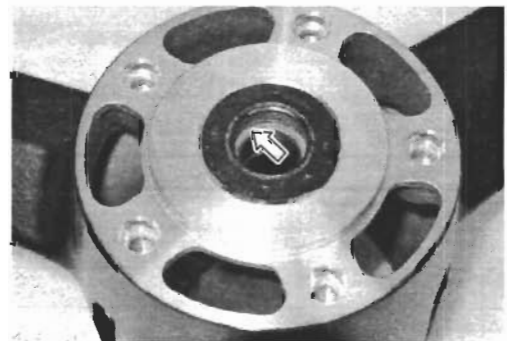
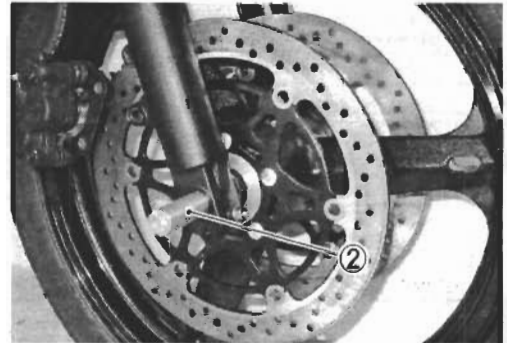
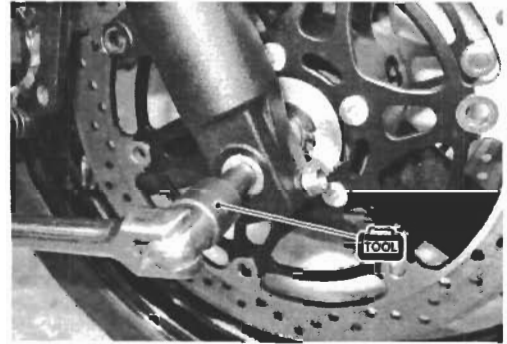
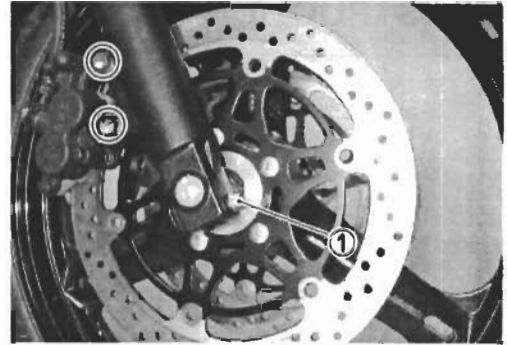

- Remove the dust seal with the special tool.

**TOOL** 09913-50121: Oil seal remover

**CAUTION**

Do not reuse the removed dust seals.

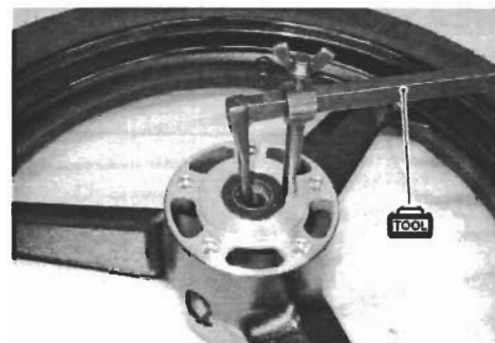

### FRONT AXLE

Using a dial gauge, check the front axle for runout and replace it if the runout exceeds the limit.

**TOOL** 09900-20607: Dial gauge (1/100)  
 09900-20701: Magnetic stand  
 09900-21304: V-block set (100 mm)

**DATA** Axle shaft runout  
 Service Limit: 0.25 mm (0.010 in)

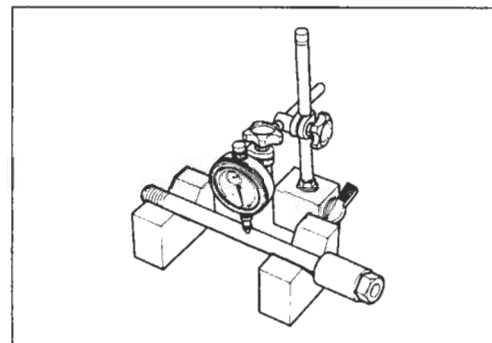

### WHEEL

Make sure that the wheel runout checked as shown does not exceed the service limit. An excessive runout is usually due to worn or loosened wheel bearings and can be reduced by replacing the bearings. If bearing replacement fails to reduce the runout, replace the wheel. (Wheel inspection:  7-79)

**DATA** Wheel runout  
 Service Limit (Axial and Radial): 2.0 mm (0.08 in)

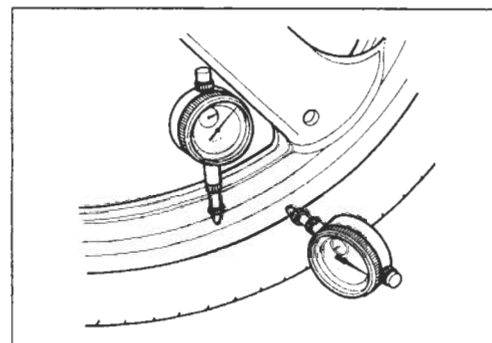

### WHEEL BEARING

Inspect the play of the wheel bearings by finger while they are in the wheel. Rotate the inner race by finger to inspect for abnormal noise and smooth rotation.

Replace the bearing in the following procedure if there is anything unusual.

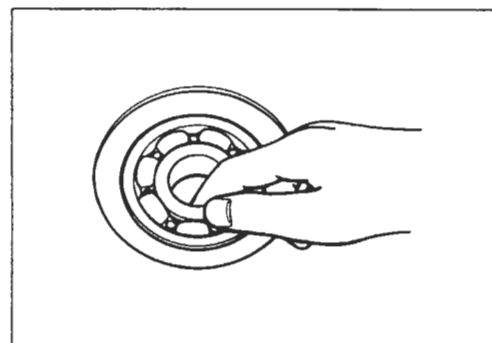

- Remove the wheel bearings with the special tool.

**TOOL** 09921-20240: Bearing remover set ( $\phi$  17)

**CAUTION**

Do not reuse the removed bearings.

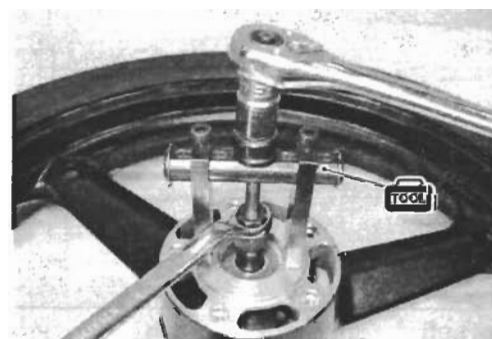

## REASSEMBLY AND REMOUNTING

Reassemble and remount the front wheel in the reverse order of removal and disassembly. Pay attention to the following points:

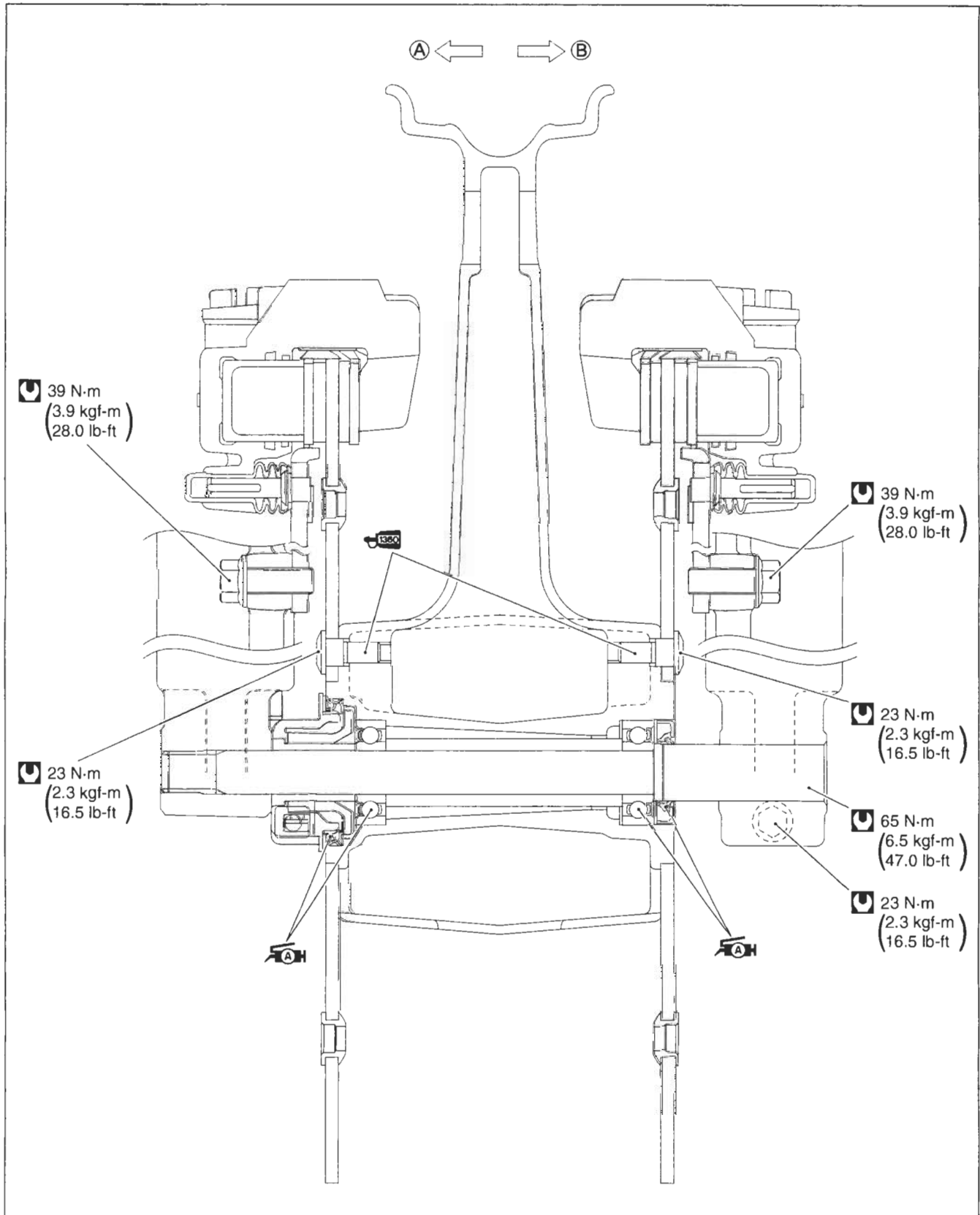

Ⓐ Left    Ⓑ Right

**WHEEL BEARING**

- Apply SUZUKI SUPER GREASE to the wheel bearings.

**TOOL** **AH** 99000-25030: SUZUKI SUPER GREASE "A" (USA)  
99000-25010: SUZUKI SUPER GREASE "A" (Others)

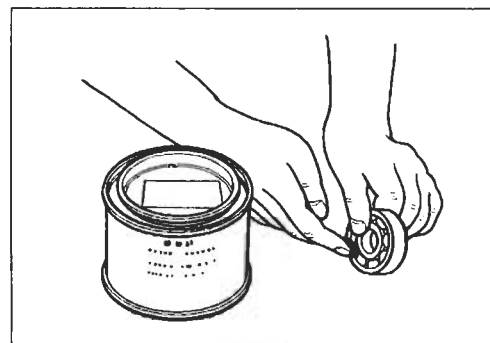

- First install the left wheel bearing, then install the right wheel bearing and spacer with the special tools and used bearing.

**TOOL** 09941-34513: Bearing/Steering race installer set  
09913-70210: Bearing installer set ( $\phi$  40)

**CAUTION**

The sealed cover of the bearing must face outside.

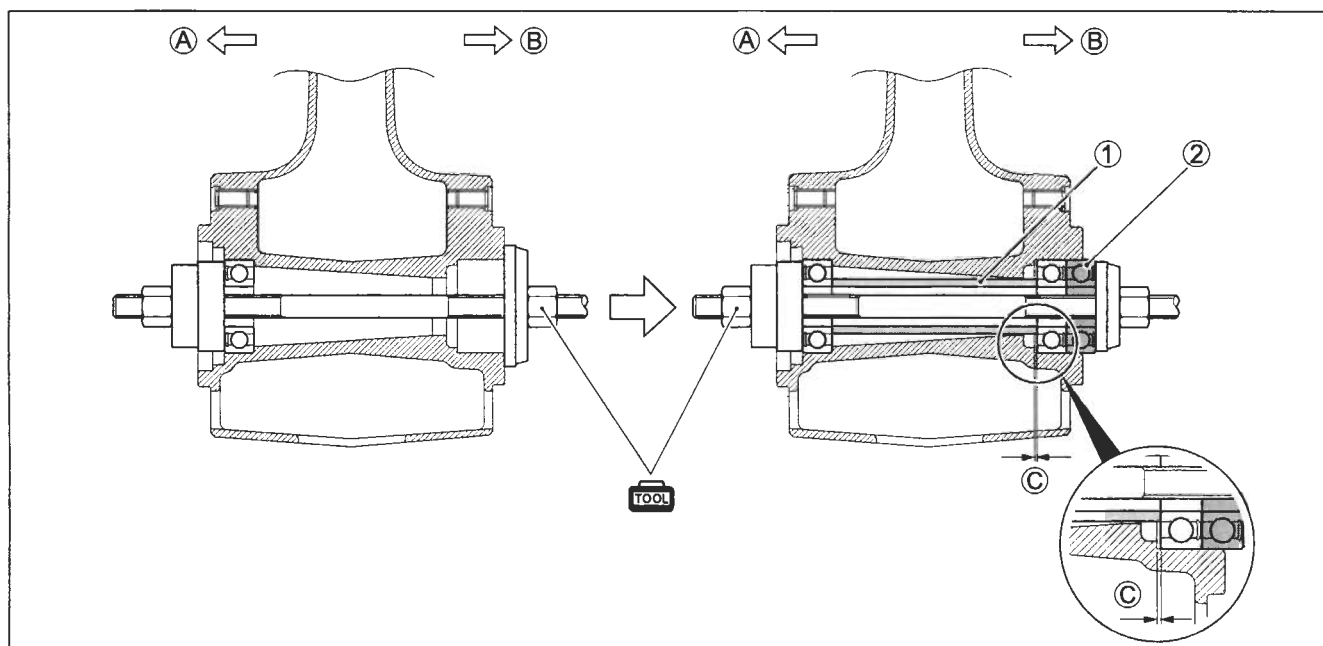
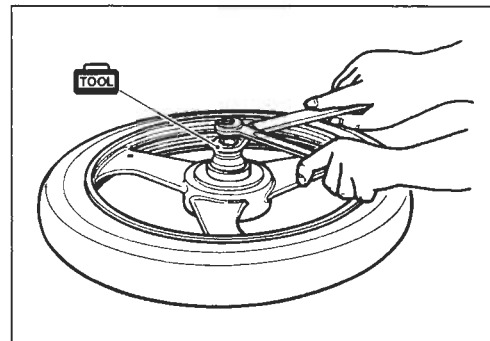

① Spacer    ② Old bearing    A Left    B Right    C Clearance

**DUST SEAL**

- Install the dust seal with the special tool.

**TOOL** 09913-70210: Bearing installer set ( $\phi$  40)

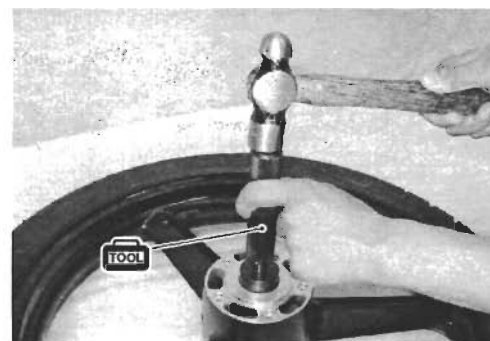

**BRAKE DISC**

Make sure that the brake disc is clean and free of any greasy matter.

- Apply **THREAD LOCK** to the disc mounting bolts and tighten them to the specified torque.

**NOTE:**

The stamped mark **(A)** on the brake disc should face to the outside.

 **Brake disc bolt: 23 N·m (2.3 kgf·m, 16.5 lb·ft)**

 **99000-32130: THREAD LOCK SUPER "1360"**

**WHEEL**

Install the front wheel with the front axle and tighten the front axle temporarily.

**⚠ WARNING**

The directional arrow **(A)** on the wheel must point to the wheel rotation, when remounting the wheel.

**BRAKE CALIPER**

- Tighten the brake caliper mounting bolts to the specified torque.

 **Front brake caliper mounting bolt:**  
**39 N·m (3.9 kgf·m, 28.0 lb·ft)**

**NOTE:**

Push the pistons all the way into the caliper and remount the calipers.

**FRONT AXLE**

- Tighten the front axle to the specified torque with the special tool.

 **09900-18710: Hexagon bit 12 mm**

 **Front axle: 65 N·m (6.5 kgf·m, 47.0 lb·ft)**

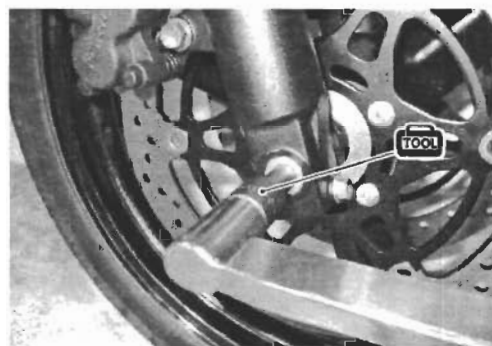
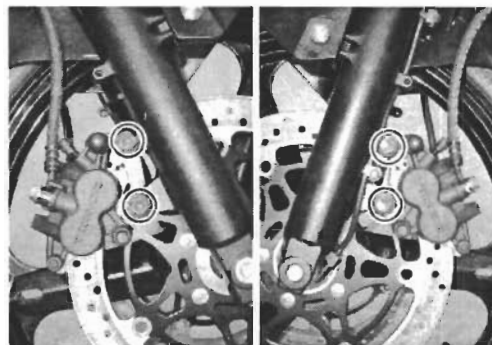
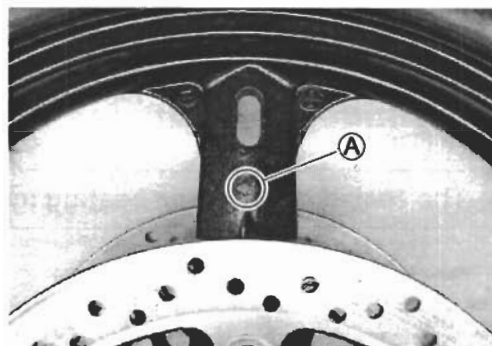
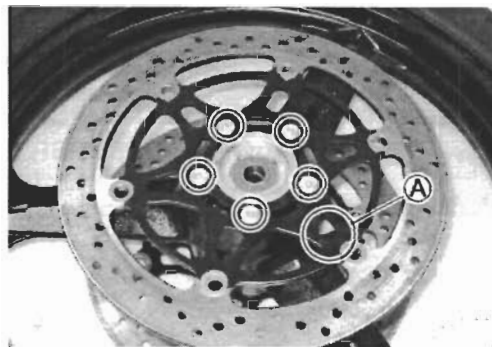

**NOTE:**

*Before tightening the axle pinch bolt on the right front fork leg, move the front fork up and down 4 or 5 times without applying front brake.*

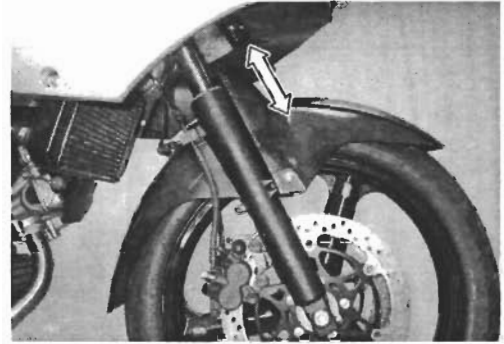

- Tighten the axle pinch bolt ① on the right front fork leg to the specified torque.

 **Front axle pinch bolt: 23 N-m (2.3 kgf-m, 16.5 lb-ft)**

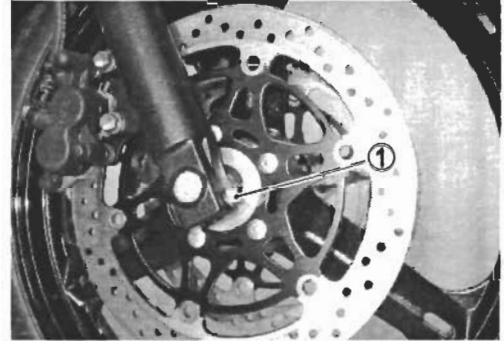

# FRONT FORK CONSTRUCTION

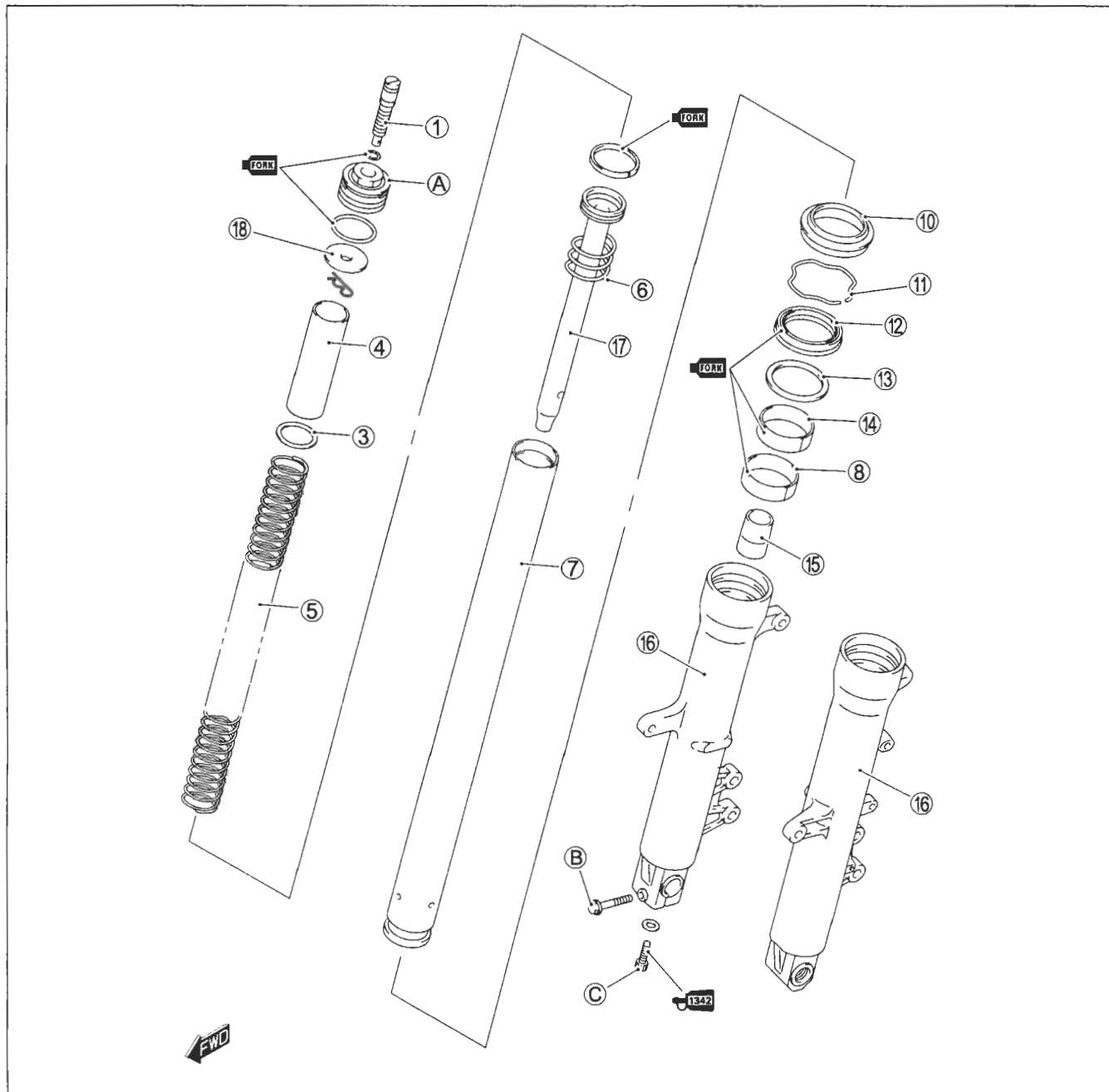

① Spring adjuster	⑫ Oil seal
② O-ring	⑬ Oil seal retainer
③ Washer	⑭ Guide metal
④ Spacer	⑮ Oil lock piece
⑤ Spring	⑯ Outer tube
⑥ Rebound spring	⑰ Cylinder
⑦ Inner tube	⑱ Washer
⑧ Slide metal	(A) Front fork cap bolt
⑨ Gasket	(B) Front axle pinch bolt
⑩ Dust seal	(C) Cylinder bolt
⑪ Oil seal stopper ring	



ITEM	N·m	kgf·m	lb·ft
(A)	23	2.3	16.5
(B)	23	2.3	16.5
(C)	20	2.0	14.5

## REMOVAL AND DISASSEMBLY

- Remove the front wheel. (☞ 7-10)
- Remove the speedometer lead wire mounting bolts ①.
- Remove the front fender bolts and brake hose bolts.
- Remove the front fender ②.

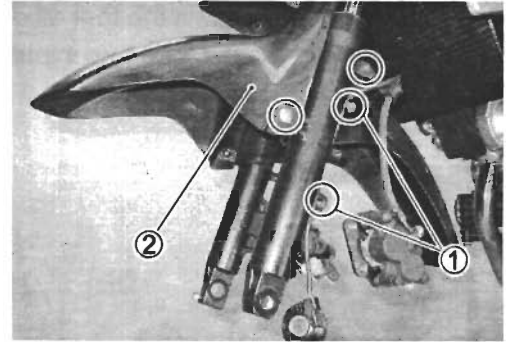

- Loosen the front fork upper clamp bolts ③.

### NOTE:

*Slightly loosen the front fork cap bolts ④ before loosening the lower clamp bolts to facilitate later disassembly.*

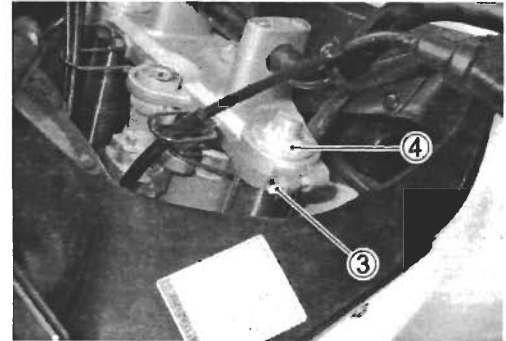

- Loosen the front fork lower clamp bolts.

### NOTE:

*Hold the front fork by the hand to prevent sliding out of the steering stem.*

- Remove the front fork.

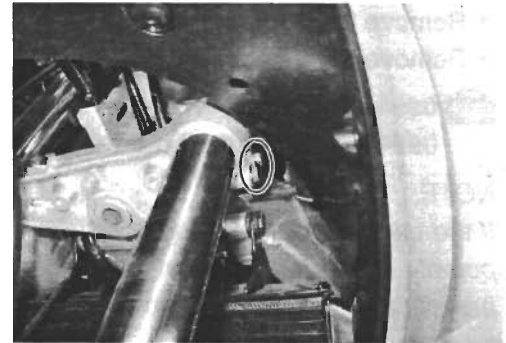

- Remove the front fork cap bolt ⑤.

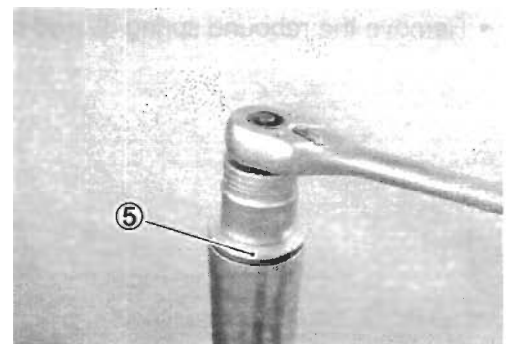

- Remove the spacer ⑥, washer ⑦ and spring ⑧.

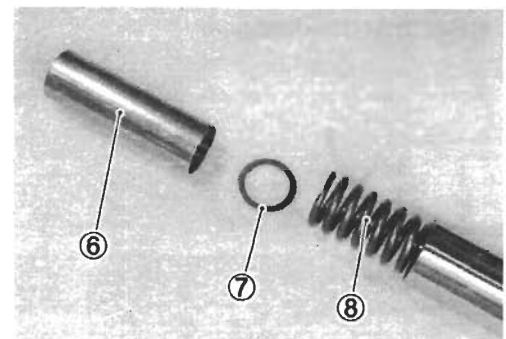



- Invert the fork and drain the fork oil out of the fork by stroking.
- Hold the fork inverted for a few minutes to drain the fork oil.

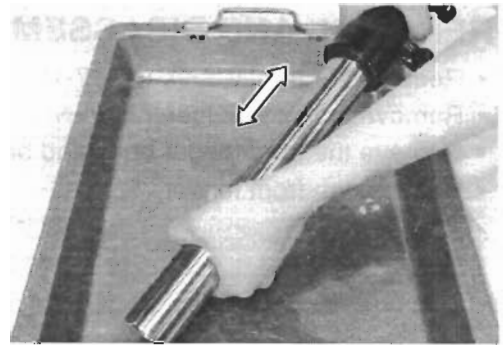

- Remove the front axle pinch bolt. (For right front fork reg)

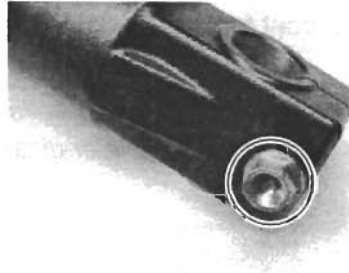

- Remove the damper rod bolt with the special tools.
- Remove the damper rod.

**TOOL** 09940-34520: "T" Handle  
09940-34531: Attachment A

**NOTE:**

*If the damper rod turns together with the damper rod bolt, temporarily install the fork spring, spacer, washer and cap bolt to prevent the damper rod from turning.*

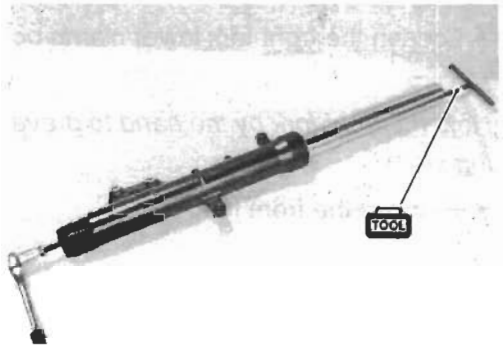

- Remove the rebound spring ⑨ and cylinder ⑩.

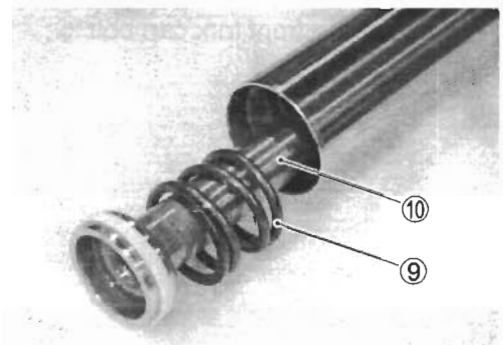

- Remove the dust seal.

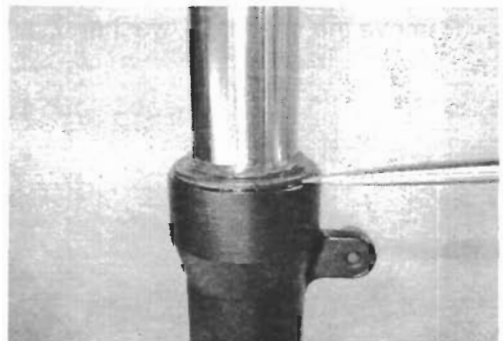

- Remove the oil seal stopper ring.

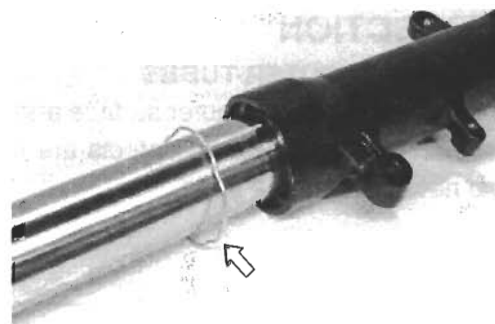

- Pull the inner tube out of the outer tube.

**NOTE:**

*Be careful not to damage the inner tube.*

**CAUTION**

The slide metals, oil seal and dust seal must be replaced with the new ones when reassembling the front fork.

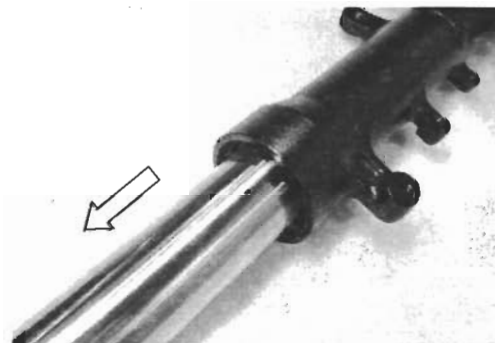

- Remove the following parts.

- ⑪ Oil seal
- ⑫ Oil seal retainer
- ⑬ Guide metal
- ⑭ Slide metal
- ⑮ Oil lock piece

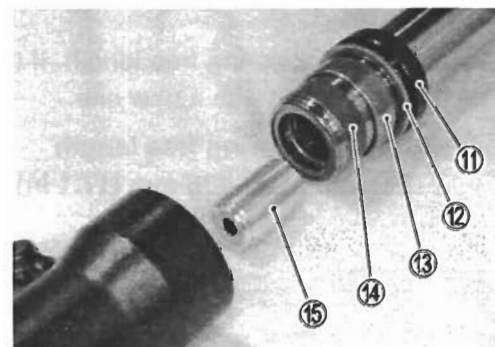

- Remove the pin ⑯.
- Remove the washer ⑰.

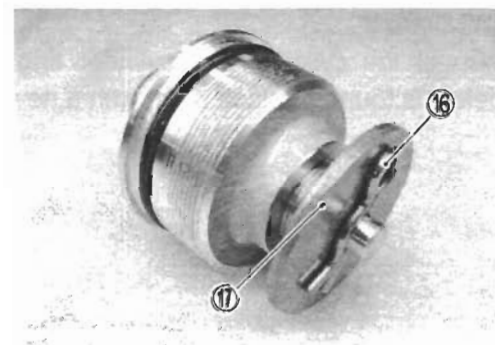

- Remove the spring adjuster ⑱ from front fork cap bolt.

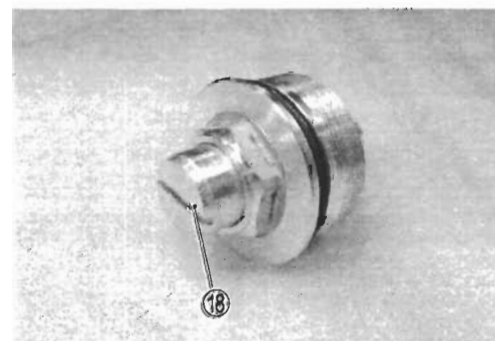

## INSPECTION

### INNER AND OUTER TUBES

Inspect the inner tube outer surface and the outer tube inner surface for scratches. If any defects are found, replace them with the new ones.



### FORK SPRING

Measure the fork spring free length. If it is shorter than the service limit, replace it with a new one.

**DATA** Front fork spring free length  
Service limit: 435 mm (17.1 in)

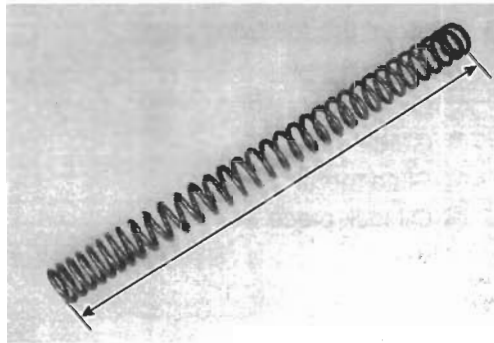

### CYLINDER

Inspect the cylinder and cylinder ring ① for damage. If any defect is found, replace them with a new one.

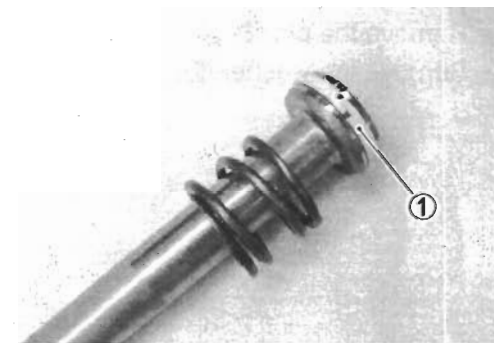

## REASSEMBLY AND REMOUNTING

Reassemble and remount the front fork in the reverse order of removal and disassembly. Pay attention to the following points:

### METALS AND SEALS

- Hold the inner tube vertically and clean the metal groove and install the guide metal by hand as shown.

#### CAUTION

- \* Use special care to prevent damage to the "Teflon" coated surface of the guide metal when mounting it.
- \* When installing the oil seal to inner tube, be careful not to damage the oil seal lip.
- \* Replace the removed metals and seals with new ones.
- \* Apply fork oil to the Anti-friction metals and lip of the oil seal.

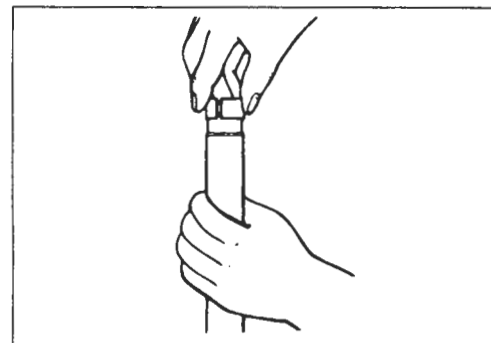

- Assemble the following parts as shown.

- ① Oil seal
- ② Oil seal retainer
- ③ Guide metal
- ④ Slide metal

#### NOTE:

Stamped mark on the oil seal must face upward.

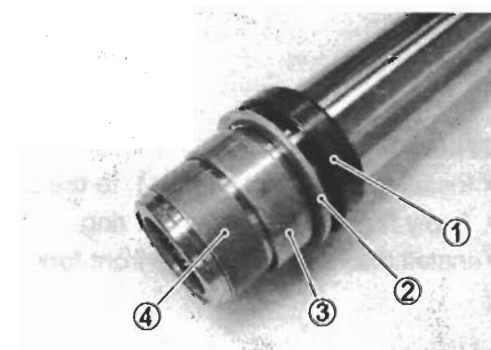

- Install the oil lock piece ⑤ into the inner tube.
- Install the inner tube into the outer tube with care not to drop the oil lock piece out.

#### NOTE:

After installing the inner tube into the outer tube, keep the oil lock piece into the inner tube by compressing the front fork fully.



- Insert the inner tube into the outer tube and fit the oil seal and dust seal with the special tool.

**TOOL** 09940-52861: Front fork oil seal installer

#### NOTE:

Stamped mark on the oil seal should face outside.

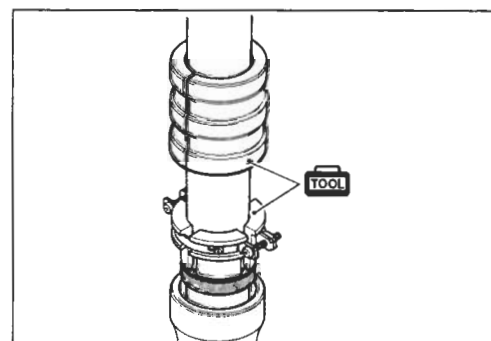

- Install the oil seal stopper ring ⑥ and the dust seal ⑦.

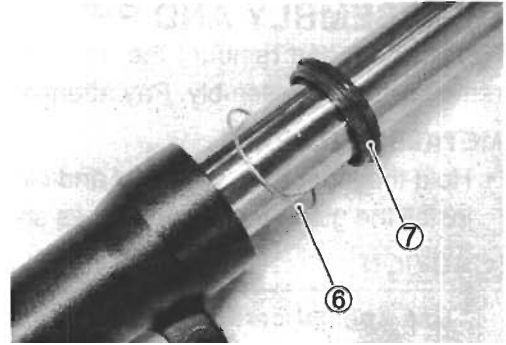

- Ⓐ Dust seal
- Ⓑ Oil seal stopper ring
- Ⓒ Oil seal
- Ⓓ Oil seal retainer
- Ⓔ Guide metal

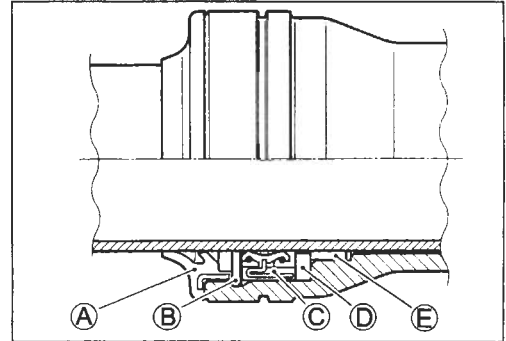

**CYLINDER**

- Install the rebound spring ① to the cylinder ②.
- Apply fork oil to the cylinder ring.
- Install the cylinder into the front fork.

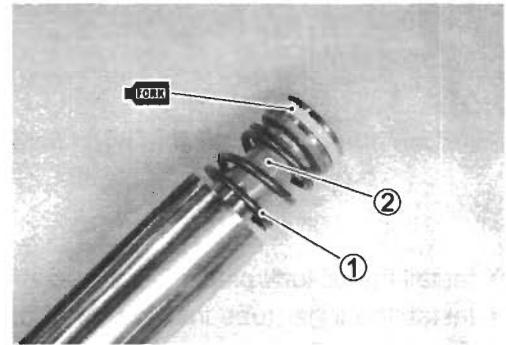

- Apply THREAD LOCK to the cylinder bolt.

**CAUTION**

Use a new gasket ③ to prevent oil leakage.

**1342** 99000-32050: THREAD LOCK "1342"

- Tighten the cylinder bolt to the specified torque with the special tools.

**09940-34520: "T" Handle**  
**09940-34531: Attachment A**

**Cylinder bolt: 20 N·m (2.0 kgf-m, 14.5 lb-ft)**

**NOTE:**

- \* If the cylinder turns together with the cylinder bolt, temporarily install the fork spring, spacer, washer and cap bolt to prevent the cylinder from turning.
- \* Check the front fork for smoothness by stroking it after installing the cylinder.

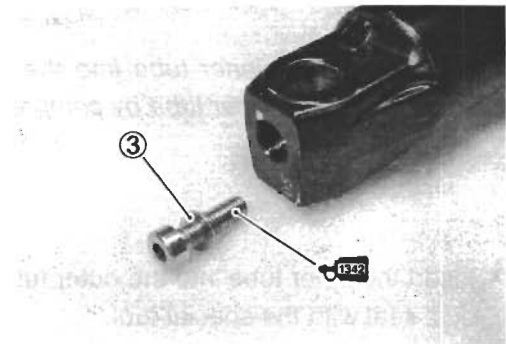

**FORK OIL**

- Place the front fork vertically without spring.
- Compress the front fork fully.
- Pour the specified front fork oil into the front fork.

**FORK** 99000-99001-SS8: SUZUKI FORK OIL SS-08

**DATA** Front fork oil capacity (each leg):  
524 ml (17.7/18.5 US/Imp oz)

- Move the inner tube up and down several strokes until no more bubbles come out from the oil.
- Keep the front fork vertically and leave it during 5 – 6 minutes.

**NOTE:**

*Take extreme attention to pump out air completely.*

- Hold the front fork vertically and adjust the fork oil level with the special tool.

**NOTE:**

*When adjusting the fork oil level, remove the fork spring and compress the inner tube fully.*

**TOOL** 09943-74111: Front fork oil level gauge

**DATA** Fork oil level: 143 mm (5.63 in)

**FORK** 99000-99001-SS8: SUZUKI FORK OIL SS-08

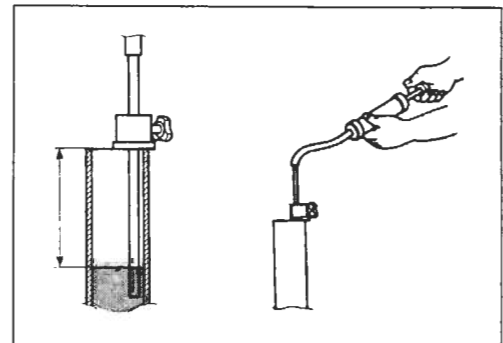
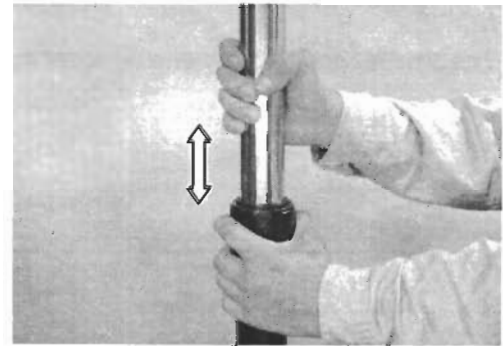
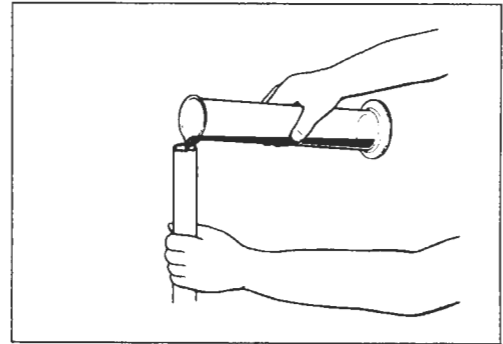

**FORK SPRING**

- Install the fork spring ① into the front fork.
- Install the washer ② and spacer ③.

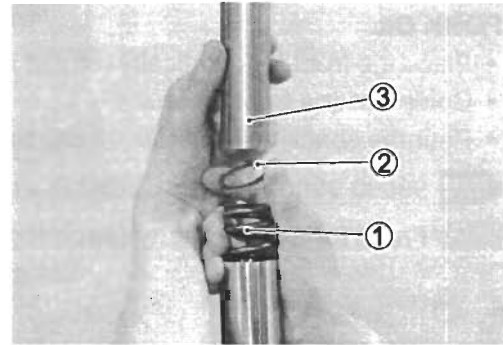
**NOTE:**

The smaller spring pitch end (A) must face downward.

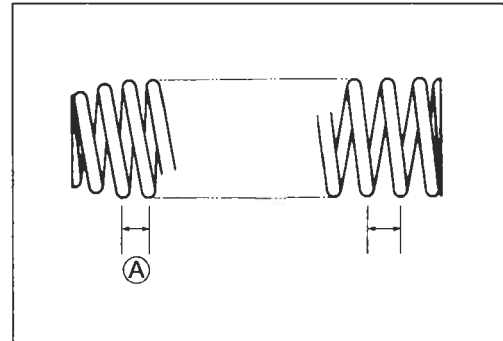

- Apply fork oil lightly to the O-ring.

**CAUTION**

Use a new O-ring to prevent oil leakage.

- Install the spring adjuster to the front fork cap bolt.

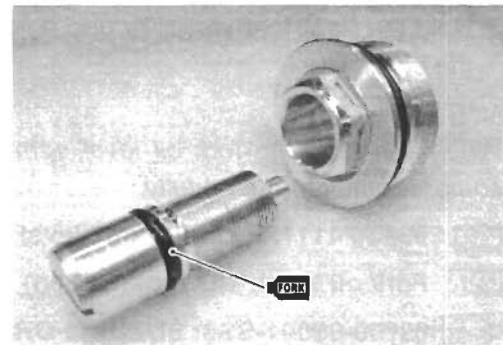

- Apply fork oil lightly to the O-ring.

**CAUTION**

Use a new O-ring to prevent oil leakage.

- Tighten the front fork cap bolt temporarily.



- Set the front fork to the front fork lower bracket temporarily by tightening the lower clamp bolts.

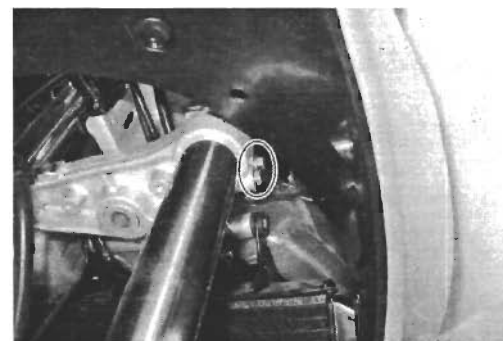

- Tighten the front fork cap bolt ④ to the specified torque.

**🔩 Front fork cap bolt: 23 N·m (2.3 kgf-m, 16.5 lb-ft)**

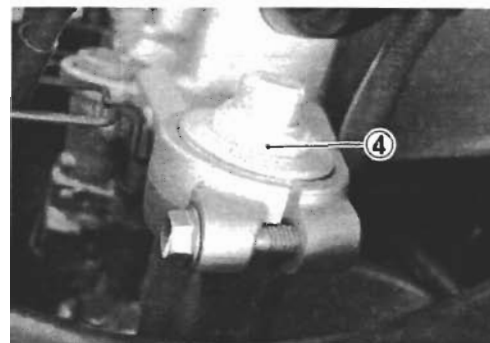

- Loosen the front fork lower clamp bolt.
- Align the top of the inner tube to the upper surface of the steering stem upper bracket.
- Tighten the front fork upper and lower clamp bolts.

**🔩 Front fork upper clamp bolt: 23 N·m (2.3 kgf-m, 16.5 lb-ft)**

**🔩 Front fork lower clamp bolt: 23 N·m (2.3 kgf-m, 16.5 lb-ft)**

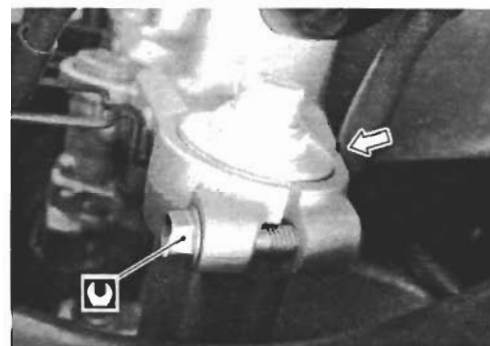

- Install the front wheel. (🔧7-10)
- Install the front brake calipers. (🔧7-59)

**NOTE:**

*After install the brake calipers, front brake should be efficient by pumping the front brake lever.*

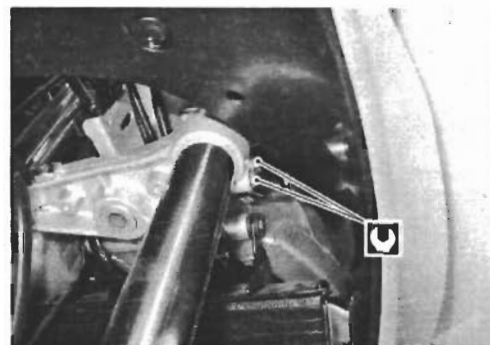

## SUSPENSION SETTING

After installing the front fork, adjust the spring pre-load as follows.

### SPRING PRE-LOAD ADJUSTMENT

There are four grooved lines on the side of the spring adjuster. Position 0 provides the maximum spring pre-load and position 5 provides the minimum spring pre-load.

**STD POSITION: 3**

**⚠ WARNING**

**Be sure to adjust the spring pre-load on both front fork legs equally.**

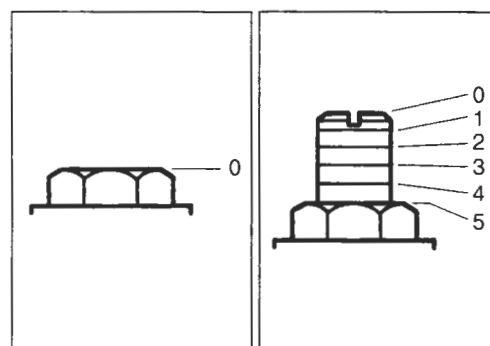



# STEERING AND HANDLEBAR CONSTRUCTION

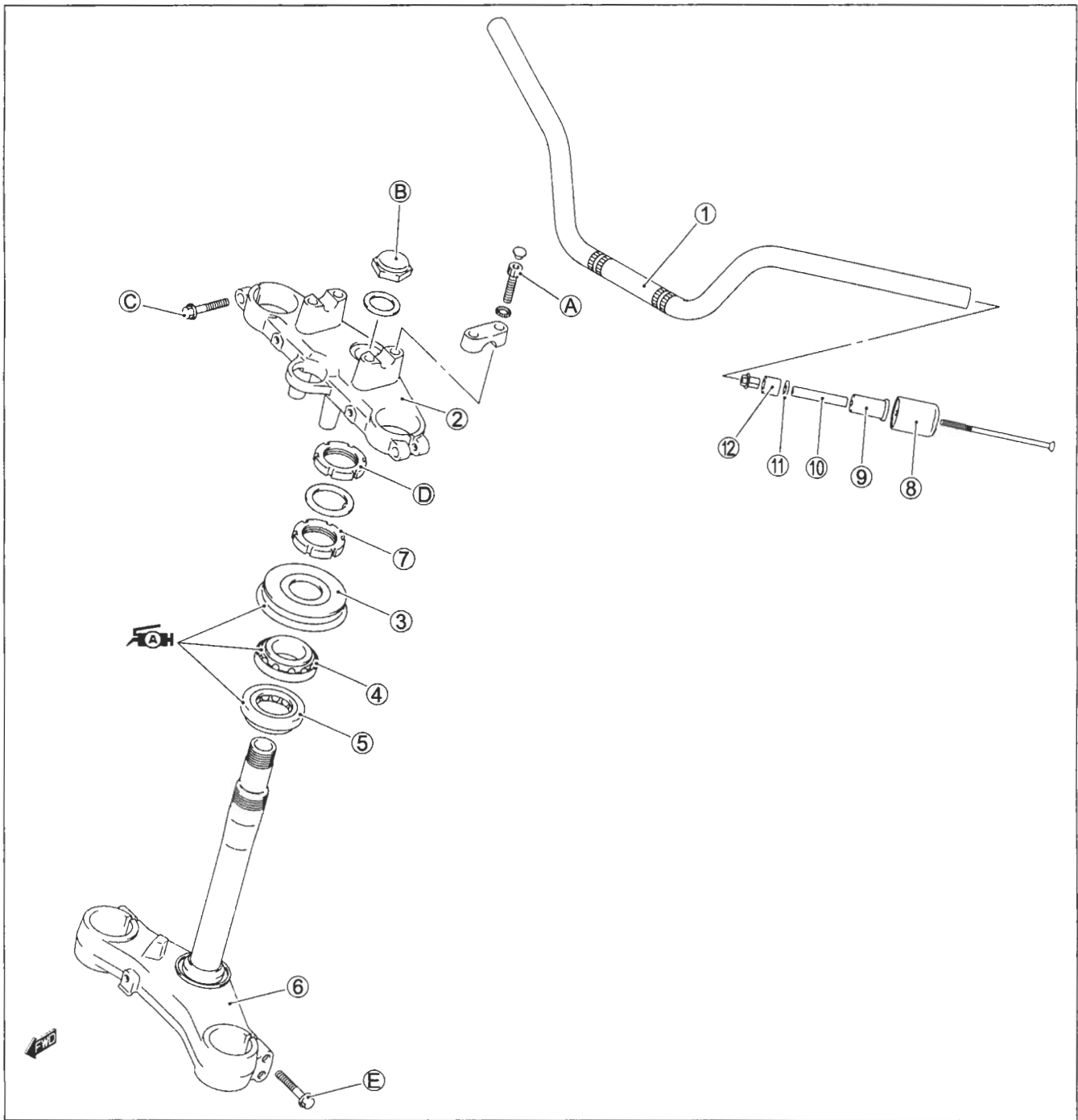

①	Handlebars	⑩	Spacer
②	Steering stem upper bracket	⑪	Washer
③	Dust seal	⑫	Expander
④	Bearing upper	A	Handlebar clamp bolt
⑤	Bearing lower	B	Steering stem head nut
⑥	Steering stem lower bracket	C	Front fork upper clamp bolt
⑦	Steering stem nut	D	Steering stem lock-nut
⑧	Handlebar balancer	E	Front fork lower clamp bolt
⑨	Expander		



ITEM	N·m	kgf·m	lb·ft
A	23	2.3	16.5
B	90	9.0	65.0
C	23	2.3	16.5
D	80	8.0	58.0
E	23	2.3	16.5

## REMOVAL HANDLEBARS

- Remove the handlebar balancers ①.
- Remove the rear view mirrors ②.

### NOTE:

*Do not remove the handlebar balancer mounting screw before removing the handlebar balancer. Slightly loosen the mounting screw, and then pull the balancer assembly out of handlebars.*

- Remove the front brake master cylinder ③.
- Remove the right handlebar switch box ④ and throttle case ⑤.

- Disconnect the clutch switch lead wire coupler ⑥.

- Remove the left handlebar switch box ⑦.
- Remove the grip rubber ⑧.
- Loosen the clutch lever holder bolt ⑨.

- Disconnect the clamps ⑩.
- Remove the clamp bolt caps ⑪.

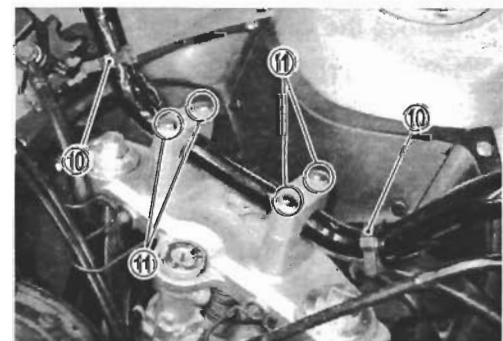
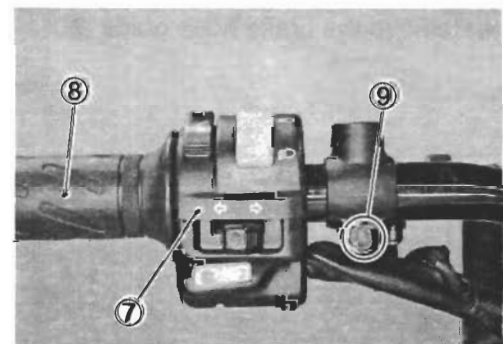
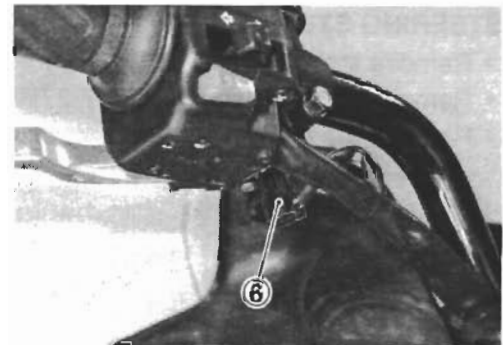
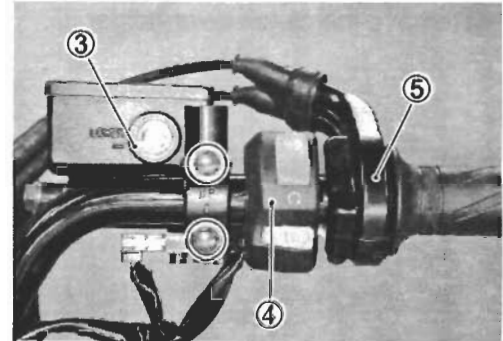
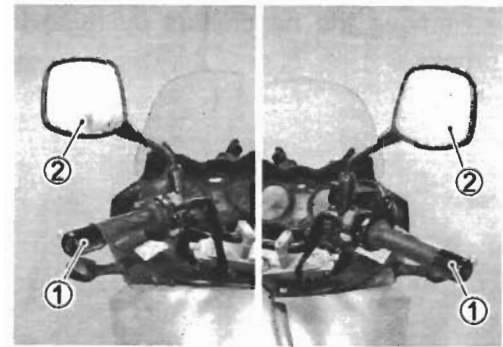

- Remove the handlebars by removing the handlebar clamp bolts.

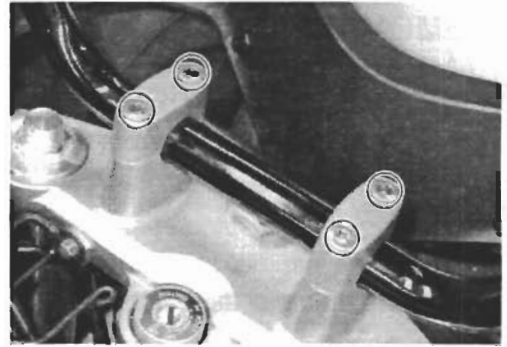

- Remove the clutch lever holder ⑫.

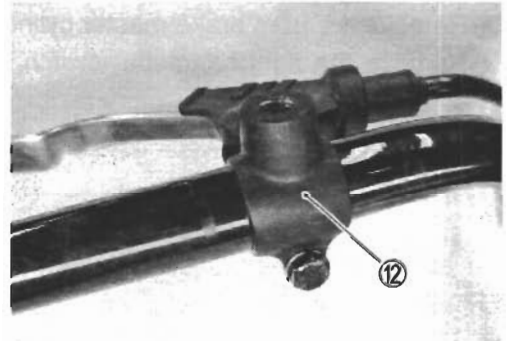

### STEERING STEM

- Remove the front forks. (☞7-17)
- Remove the handlebars. (☞7-27)
- Remove the guides ①.

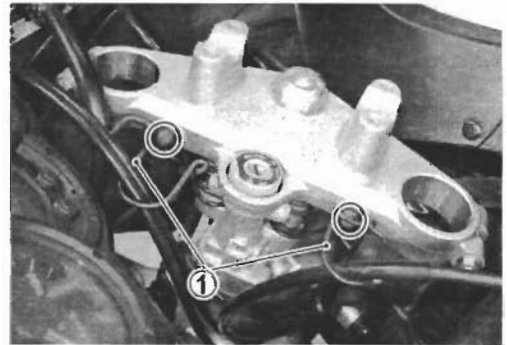

- Remove the brake hose guide ②.

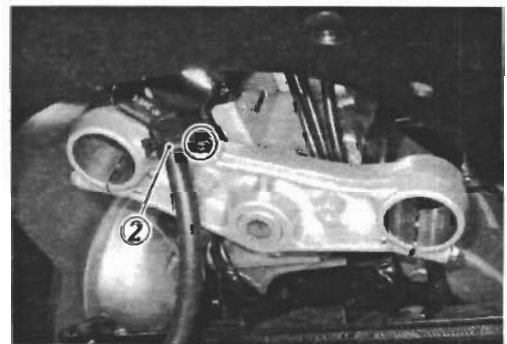

- Remove the ignition switch ③ with the special tools.

 **09930-11920: Torx bit JT40H**  
**09930-11940: Bit holder**



- Remove the steering stem upper bracket by removing the steering stem head nut.



- Remove the steering stem lock-nut with the special tools.

**TOOL** 09940-14911: Steering stem nut wrench  
 09940-14960: Steering stem nut wrench socket

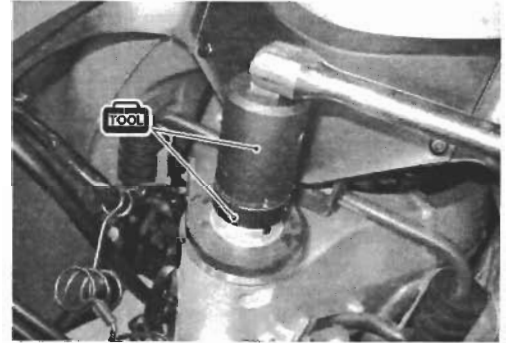

- Remove the washer ④.



- Remove the steering stem nut with the special tools.

**TOOL** 09940-14911: Steering stem nut wrench  
 09940-14960: Steering stem nut wrench

**NOTE:**

*When loosening the steering stem nut, hold the steering stem lower bracket to prevent it from falling.*

- Remove the steering stem lower bracket.



- Remove the dust seal ⑤ and bearing inner race ⑥.

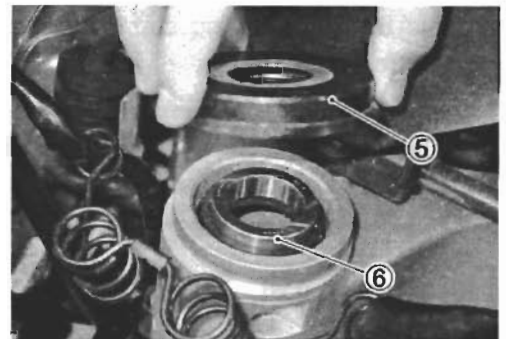

- Remove the steering stem upper bearing ⑦.

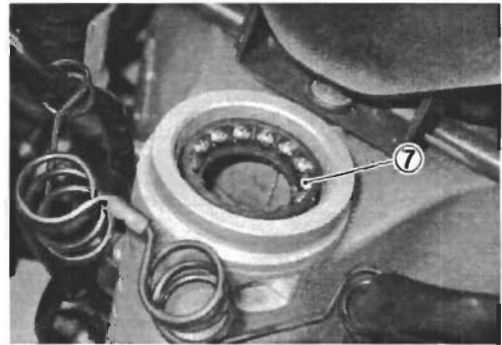

- Remove the steering stem lower bearing ⑧.

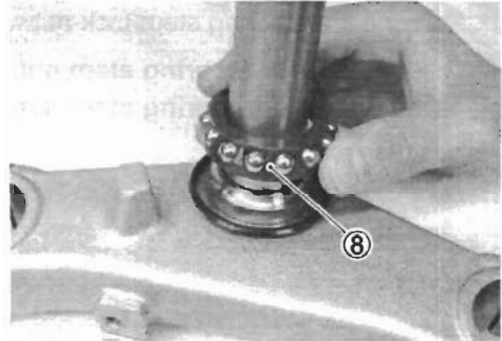

## INSPECTION AND DISASSEMBLY

Inspect the removed parts for the following abnormalities.

- \* Distortion of the steering stem
- \* Bearing wear or damage
- \* Abnormal bearing noise
- \* Handlebars restriction
- \* Race wear and brinelling

If any abnormal points are found, replace defective parts with the new ones.



- Remove the steering stem lower bearing inner race using a chisel.

### CAUTION

The removed bearing inner race and dust seal must be replaced with the new ones.

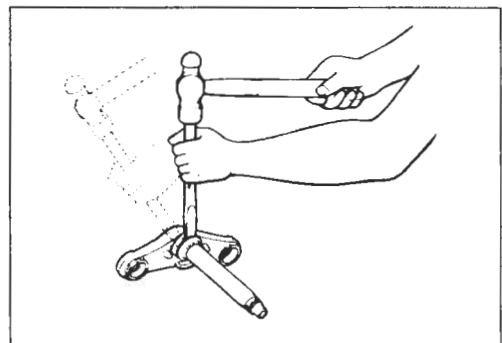

- Drive out the steering stem upper and lower bearing races with the special tools.

**TOOL** 09941-54911: Bearing outer race remover  
09925-18011: Steering bearing installer

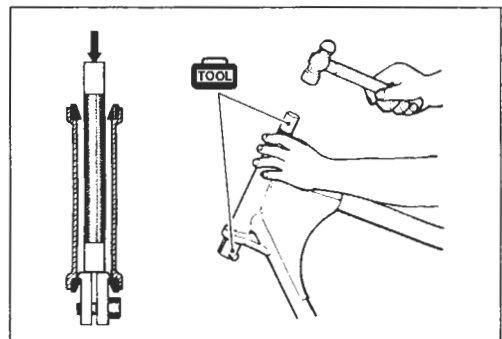

## REASSEMBLY AND REMOUNTING

Reassemble and remount the steering stem in the reverse order of removal and disassembly. Pay attention to the following points:

### OUTER RACES

- Press in the upper and lower outer races with the special tool.

 **09941-34513: Steering outer race installer**  
**09913-70210: Bearing installer set ( $\phi$  55)**

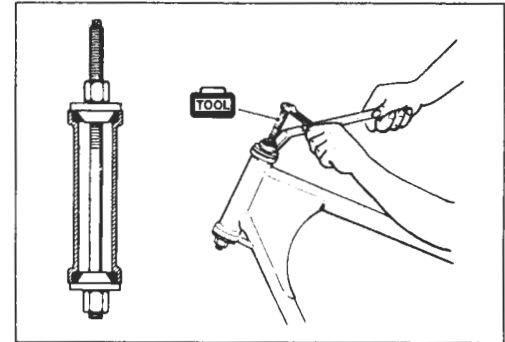

### BEARINGS

- Press in the dust seal and lower bearing with the special tool.

 **09925-18011: Steering bearing installer**

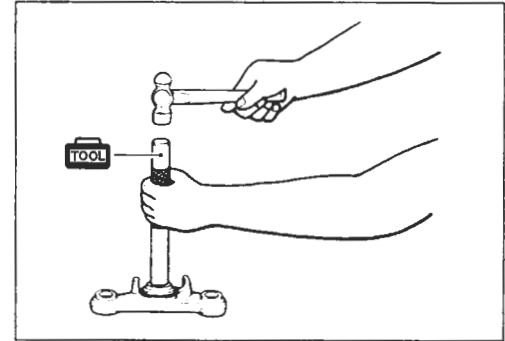

- Apply SUZUKI SUPER GREASE to the bearings and dust seal.
- Install the lower bearing to the steering stem lower bracket.
- Install the upper bearing, bearing inner race, dust seal onto the frame.

 **99000-25030: SUZUKI SUPER GREASE "A" (USA)**  
**99000-25010: SUZUKI SUPER GREASE "A" (Others)**

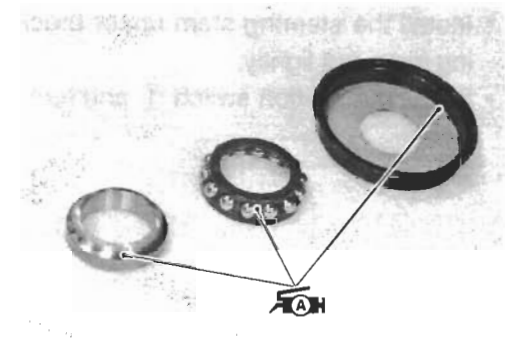

### STEERING STEM

- Tighten the steering stem nut to the specified torque with the special tools.

 **09940-14911: Steering stem nut wrench**  
**09940-14960: Steering stem nut wrench socket**

 **Steering stem nut: 45 N·m (4.5 kgf-m, 32.5 lb-ft)**

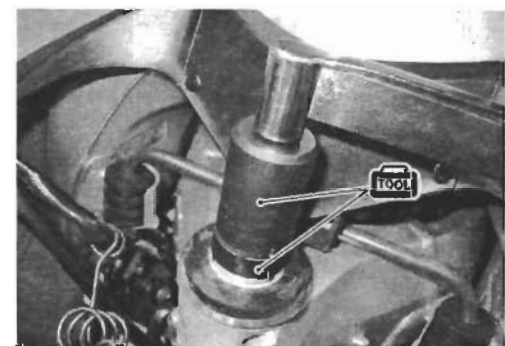

- Turn the steering stem about five or six times to the left and right so that the angular ball bearing will be seated properly.
- Loosen the steering stem nut by 1/4 – 1/2 turn.

### NOTE:

*This adjustment will vary from motorcycle to motorcycle.*

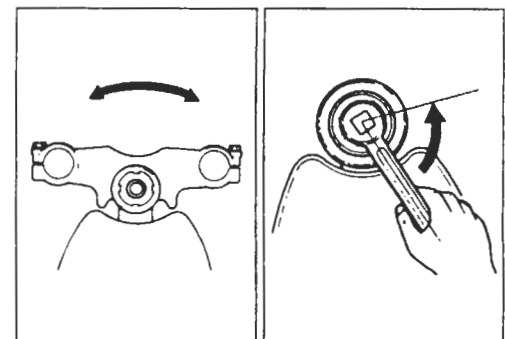

- Install the washer.

**NOTE:**

When installing the washer, align the stopper lug to the groove of the steering stem.

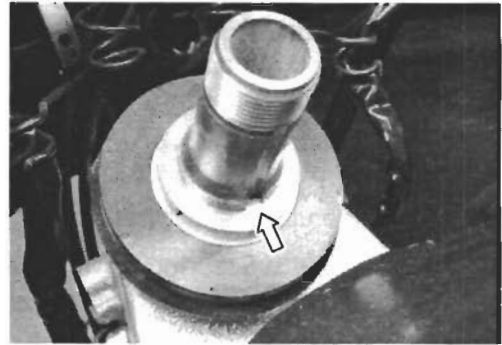

- Install the steering stem lock-nut and tighten it to the specified torque with the special tools.

**TOOL** 09940-14911: Steering stem nut wrench  
09940-14960: Steering stem nut wrench socket

**U** Steering stem lock-nut: 80 N·m (8.0 kgf·m, 58.0 lb·ft)

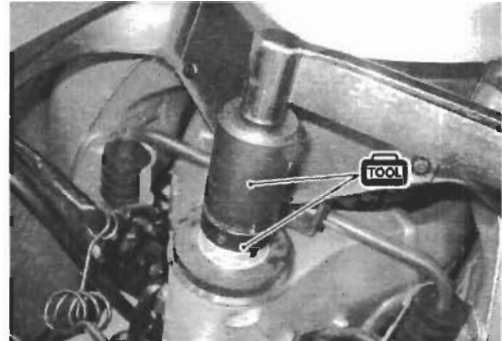

- Install the steering stem upper bracket and tighten the steering stem nut lightly.
- Install the ignition switch ① and harness guide ②. (↗8-38)

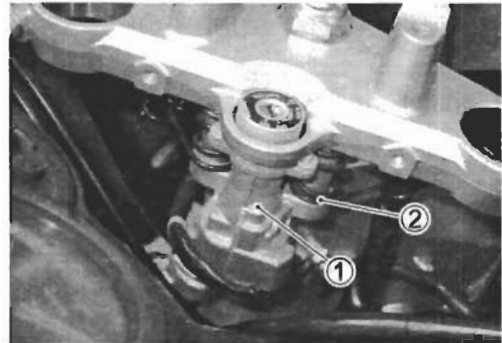

- Install the front fork to the steering stem and tighten the lower clamp bolts temporarily.
- Tighten the steering stem head nut to the specified torque.

**U** Steering stem head nut: 90 N·m (9.0 kgf·m, 65.0 lb·ft)

- Remount the front forks and the front fender. (↗7-21)

**HANDLEBARS**

- Install the handlebars with the punch mark Ⓐ aligned with the mating surface Ⓑ of the handlebar holder.

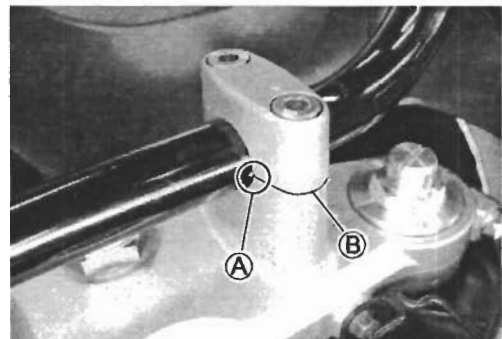

- Set the punch mark © on the handlebar clamp forward.
- Tighten the handlebar clamp bolts to the specified torque.

 **Handlebar clamp bolt: 23 N·m (2.3 kgf·m, 16.5 lb·ft)**

**NOTE:**

*When tightening the handlebar clamp bolts, first tighten the bolt*

*① and then tighten the bolt ②.*

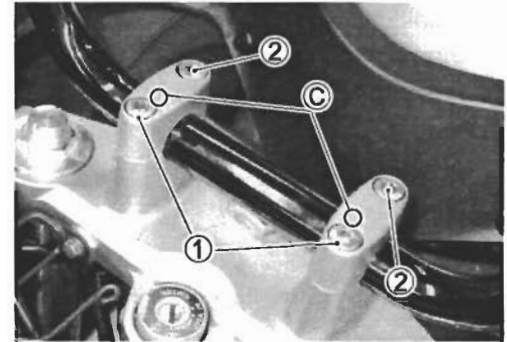

**HANDLEBAR SWITCH BOX**

- Install the throttle cable case.
- Apply SUZUKI SUPER GREASE to the throttle cables and their holes.

 **99000-25030: SUZUKI SUPER GREASE "A" (USA)**  
**99000-25010: SUZUKI SUPER GREASE "A" (Others)**



- Align the mating surface ⑥ of the throttle case with the punch mark ⑤ on the handlebars.

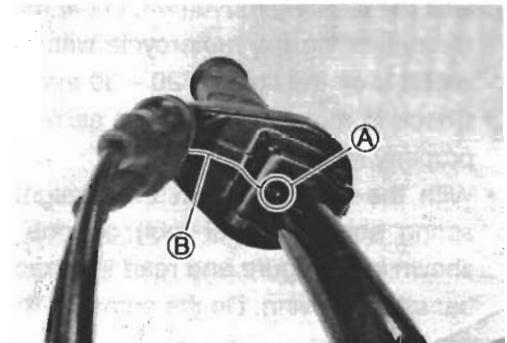

- Install the right handlebar switch box to the handlebars by engaging the stopper ① with the handlebar's hole ②.
- Install the front brake master cylinder. (☞ 7-67)

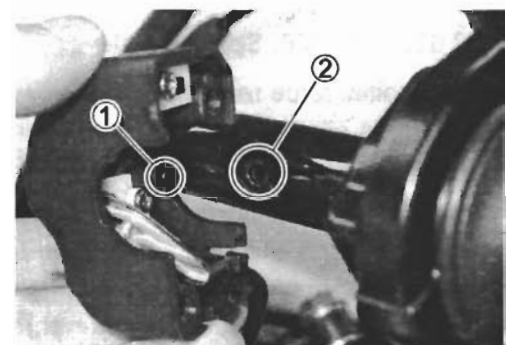

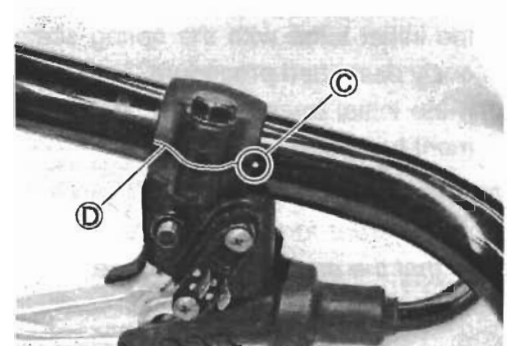

- Install the handlebars with the punch mark © aligned with the mating surface ④ of the clutch lever holder.



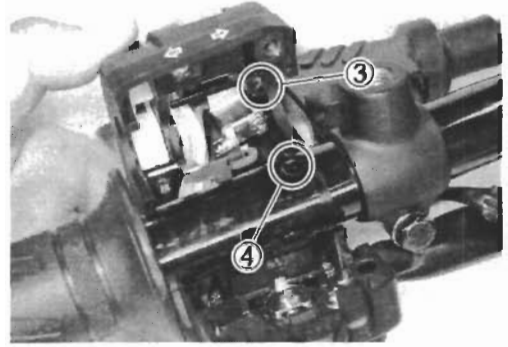

- Install the left handlebar switch box to the handlebars by engaging the stopper ③ with the handlebars hole ④.
- Install the clutch master cylinder with the proper clutch hose routing.



- Install the handlebar balancers and the rear view mirrors. (Handlebar balancer installation:  9-35)
- Install the front wheel. ( 7-12)

## STEERING TENSION ADJUSTMENT

Check the steering movement in the following procedure.

- By supporting the motorcycle with a jack, lift the front wheel until it is off the floor by 20 – 30 mm (0.8 – 1.2 in).
- Check to make sure that the cables and wire harnesses are properly routed.
- With the front wheel in the straight ahead state, hitch the spring scale (special tool) on one handlebar grip end as shown in the figure and read the graduation when the handlebar starts moving. Do the same on the other grip end.

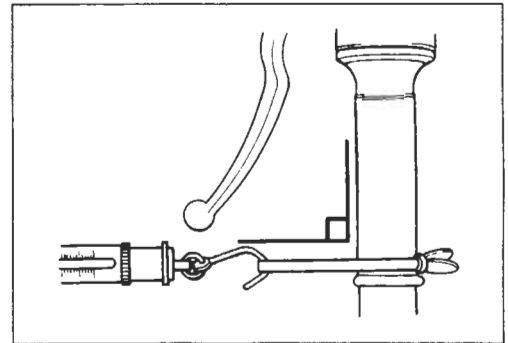

**DATA** Initial force: 200 – 500 grams

**TOOL** 09940-92720: Spring scale

- If the initial force read on the scale when the handlebar starts turning is either too heavy or too light, adjust it till it satisfies the specification.
- 1) First, loosen the front fork upper clamp bolts, steering stem head nut and steering stem lock-nut, and then adjust the steering stem nut by loosening or tightening it.
  - 2) Tighten the steering stem lock-nut, stem head nut and front fork upper clamp bolts to the specified torque and re-check the initial force with the spring scale according to the previously described procedure.
  - 3) If the initial force is found within the specified range, adjustment has been completed.

### NOTE:

Hold the front fork legs, move them back and forth and make sure that the steering is not loose.

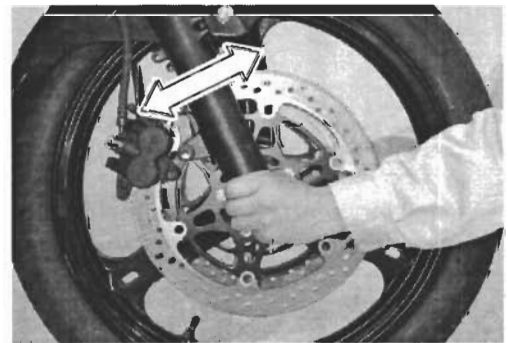

# REAR WHEEL CONSTRUCTION

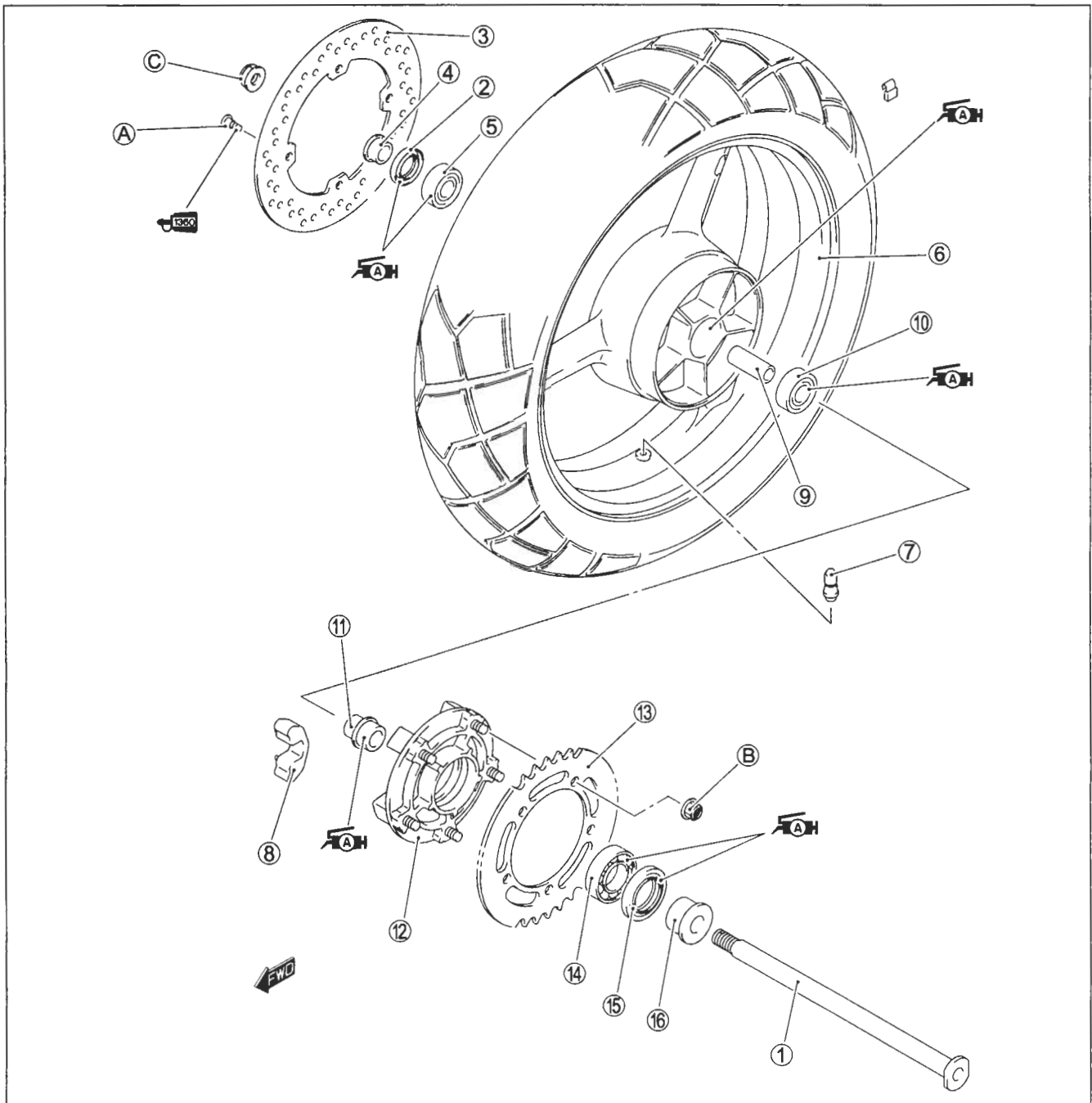

① Rear axle	⑪ Retainer
② Dust seal	⑫ Sprocket mounting drum
③ Brake disc	⑬ Rear sprocket
④ Collar	⑭ Bearing
⑤ Bearing	⑮ Dust seal
⑥ Rear wheel	⑯ Collar
⑦ Tire valve	Ⓐ Brake disc bolt
⑧ Damper	Ⓑ Rear sprocket nut
⑨ Spacer	Ⓒ Rear axle nut
⑩ Bearing	



ITEM	N-m	kgf-m	lb-ft
Ⓐ	23	2.3	16.5
Ⓑ	60	6.0	43.5
Ⓒ	100	10.0	72.5

## REMOVAL

- Remove the cotter pin. (For E-03, 28, 33)
- Loosen the rear axle nut.
- Raise the rear wheel off the ground and support the motorcycle with a jack or wooden block.
- Remove the axle nut and draw out the rear axle.

### CAUTION

Do not operate the brake pedal while removing the rear wheel.

- Remove the collars ①, ②.

- Remove the rear sprocket mounting drum assembly ③ from the wheel hub.

### NOTE:

Before removing the rear sprocket mounting drum, slightly loosen the rear sprocket nuts ④ to facilitate later disassembly.

- Remove the rear sprocket mounting drum retainer ⑤.

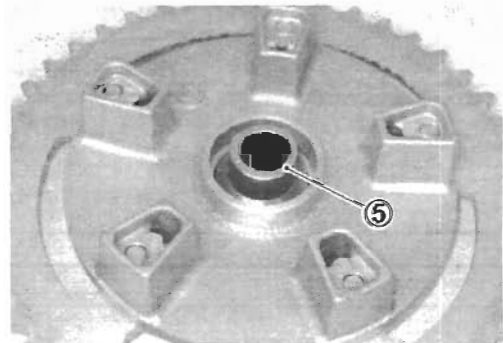
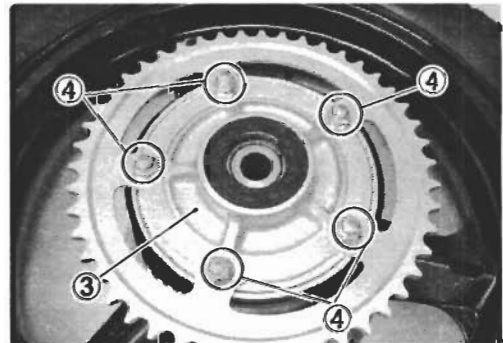
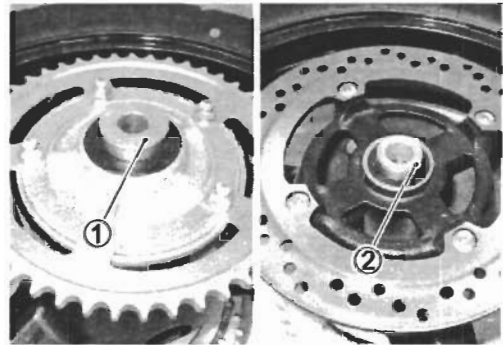
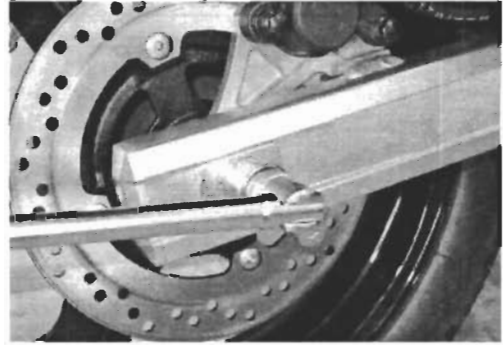

- Remove the rear sprocket ⑥ from the rear sprocket mounting drum.

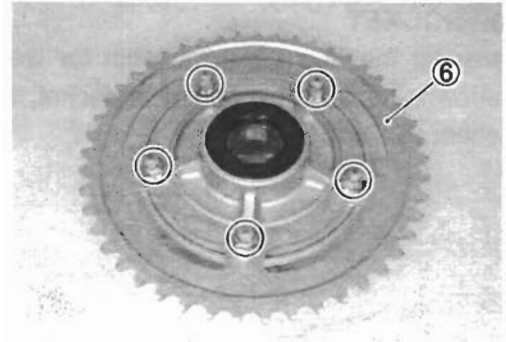

- Remove the brake disc ⑦.

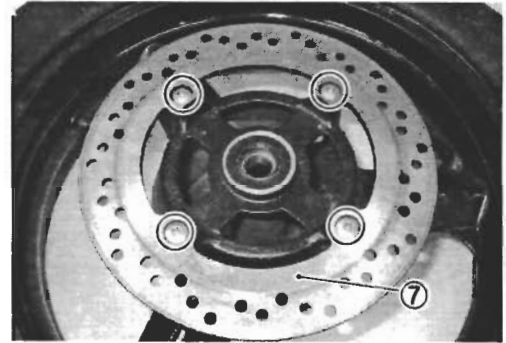

## INSPECTION AND DISASSEMBLY

TIRE: (☞ 7-79)

WHEEL: (☞ 7-11 and 7-79)

### REAR AXLE

Using a dial gauge, check the rear axle for runout. If the runout exceeds the limit, replace the rear axle.

**DATA** Axle shaft runout: Service Limit: 0.25 mm (0.010 in)

**TOOL** 09900-20607: Dial gauge (1/100 mm)  
09900-20701: Magnetic stand  
09900-21304: V-block set (100 mm)

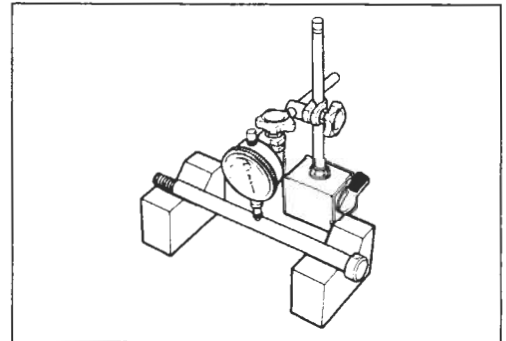

### WHEEL DAMPER

Inspect the dampers for wear and damage. Replace the damper if there is anything unusual.

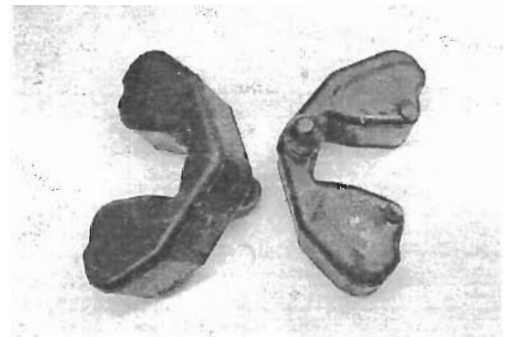

**SPROCKET**

Inspect the rear sprocket teeth for wear. If they are worn as shown, replace the engine sprocket, rear sprocket and drive chain as a set.

- Ⓐ Normal wear
- Ⓑ Excessive wear

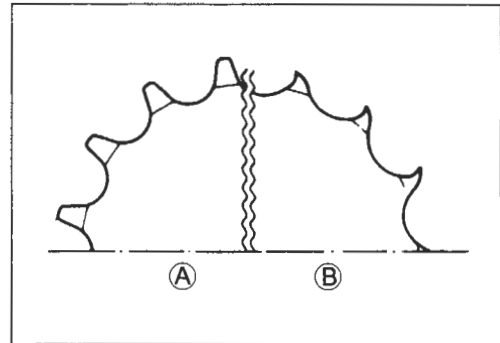
**DUST SEAL**

- Inspect the wheel dust seal lip and sprocket mounting drum dust seal lips for wear or damage. If any damages are found, replace the dust seal with a new one.

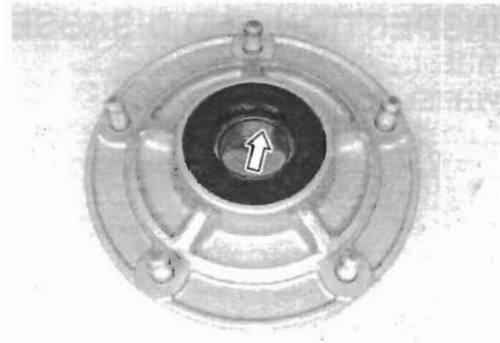

- Remove the dust seal with the special tool.

**TOOL** 09913-50121: Oil seal remover

**CAUTION**

**Do not reuse the removed dust seal.**

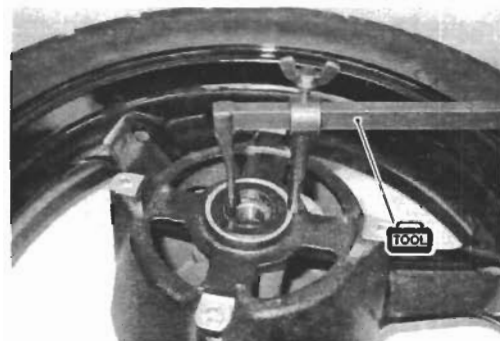
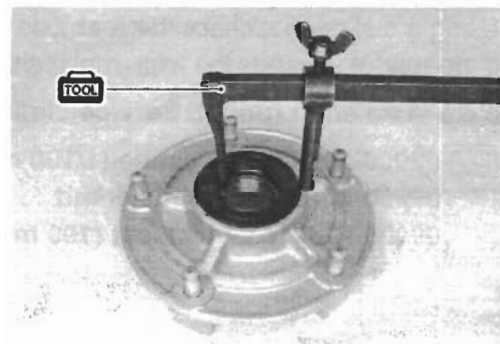

**BEARING**

Inspect the play of the wheel and sprocket mounting drum bearings by hand while they are in the wheel and drum. Rotate the inner race by hand to inspect for abnormal noise and smooth rotation. Replace the bearing if there is anything unusual.

- Remove the sprocket mounting drum bearing and wheel bearings with the special tool.

**TOOL** 09921-20240: Bearing remover set (①  $\phi$  30)  
(②  $\phi$  20)

**CAUTION**

The removed bearings must be replaced with the new ones.

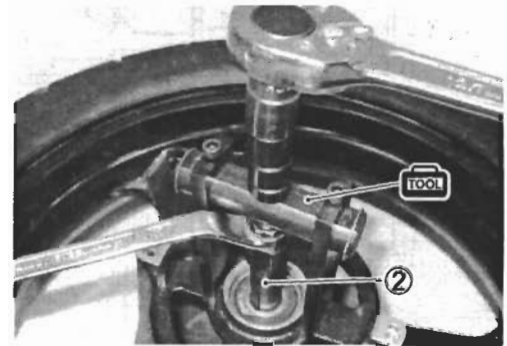
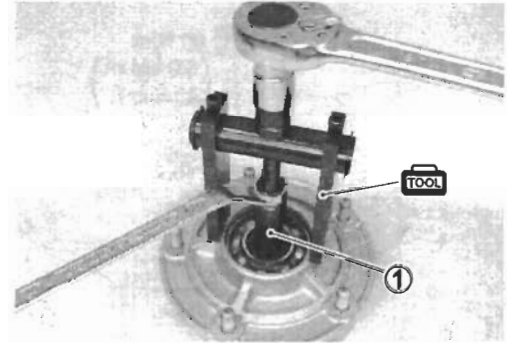
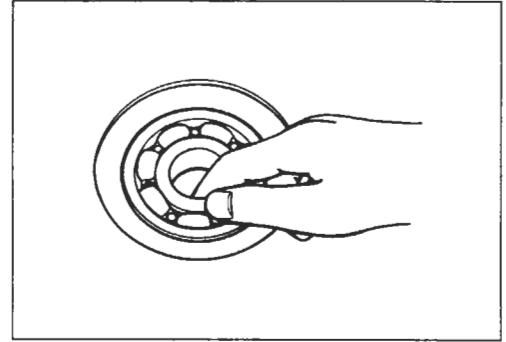

## REASSEMBLY AND REMOUNTING

Reassemble and remount the rear wheel in the reverse order of removal and disassembly. Pay attention to the following points:

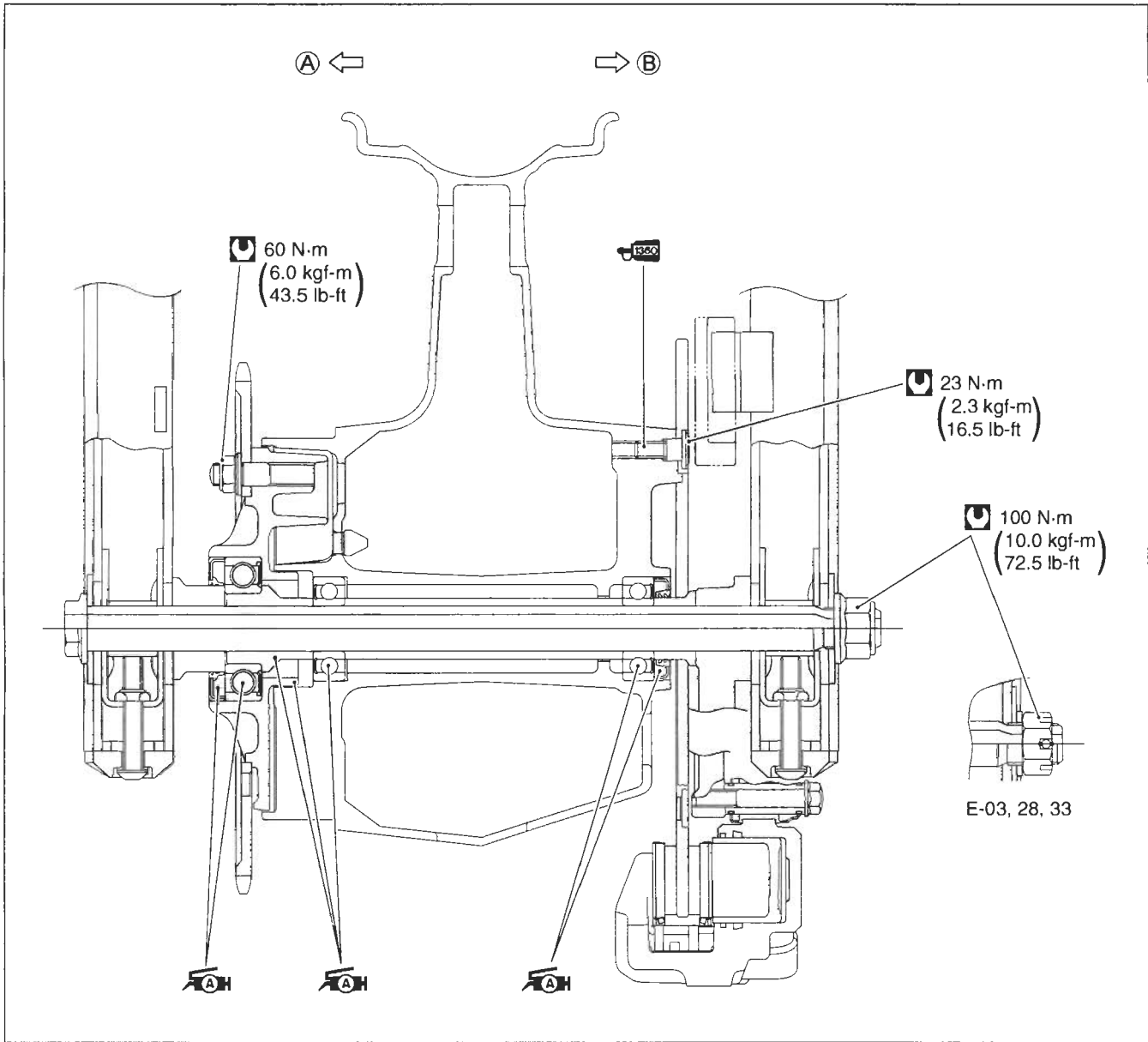

① Left    ① Right

**BEARING**

- Apply SUZUKI SUPER GREASE to the bearings before installing.

**TOOL** 99000-25030: SUZUKI SUPER GREASE "A" (USA)  
 99000-25010: SUZUKI SUPER GREASE "A" (Others)

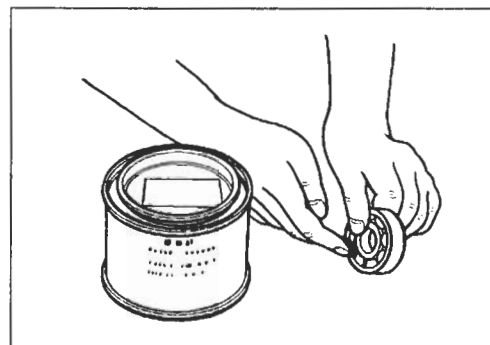

- Install the new bearing to the sprocket mounting drum with the special tool.

**TOOL** 09913-70210: Bearing installer set (φ 62)

**NOTE:**

*When installing the bearing, non-sealed side of bearing must face the special tool.*

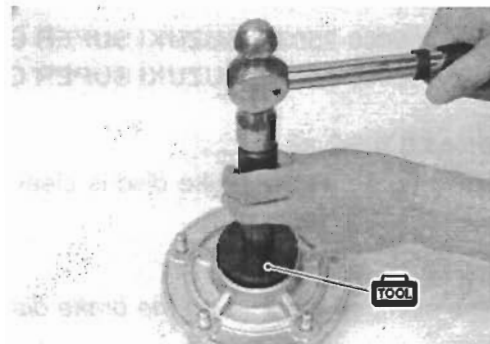

- First install the right wheel bearing, then install the left wheel bearing and spacer with the special tools.

**TOOL** 09941-34513: Bearing/Steering race installer set  
 09913-70210: Bearing installer set (φ 47)

**CAUTION**

The sealed cover of the bearing must face outside.

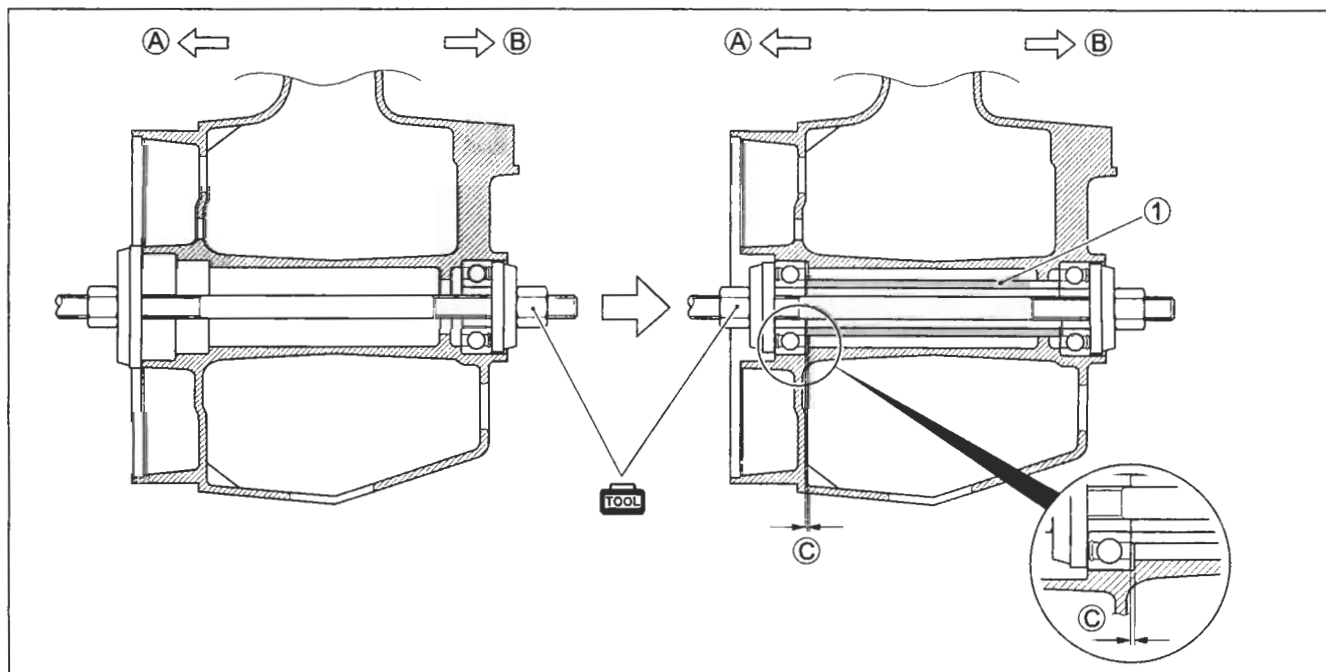
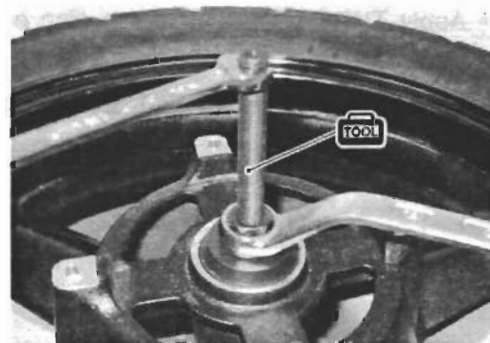

① Spacer    Ⓐ Left    Ⓑ Right    Ⓒ Clearance



**DUST SEAL**

- Install the new dust seals with the special tool.

 **09913-70210: Bearing installer set (① φ 62)  
(② φ 47)**

**NOTE:**

*When installing the dust seals, the stamped mark of dust seal must face the special tool.*

- Apply SUZUKI SUPER GREASE to the dust seal lips before assembling rear wheel.

 **99000-25030: SUZUKI SUPER GREASE "A" (USA)  
99000-25010: SUZUKI SUPER GREASE "A" (Others)**

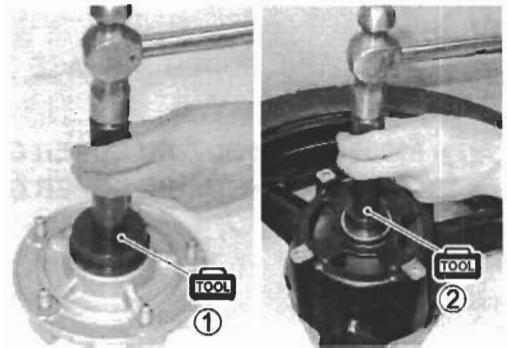
**BRAKE DISC**

Make sure that the brake disc is clean and free of any greasy matter.

**NOTE:**

*The stamped mark (A) on the brake disc should face to the outside.*

- Apply THREAD LOCK to the disc bolts and tighten them to the specified torque.

 **99000-32130: THREAD LOCK SUPER "1360"**

 **Brake disc bolt: 23 N·m (2.3 kgf-m, 16.5 lb-ft)**

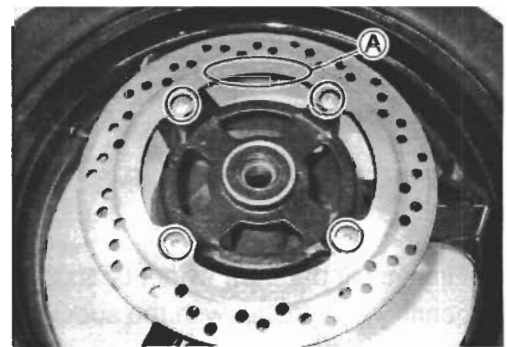
**REAR SPROCKET**

- Install the rear sprocket to the rear sprocket mounting drum.

**NOTE:**

*Stamped mark (A) on the sprocket must face outside.*

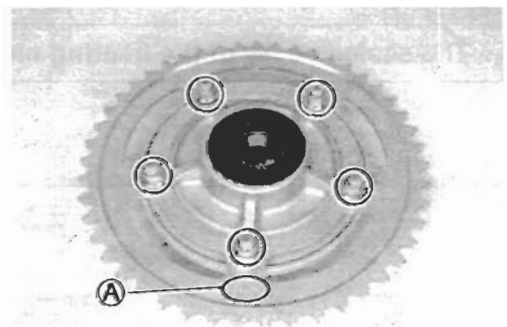

- Apply SUZUKI SUPER GREASE to the rear sprocket mounting retainer.
- Install the rear sprocket mounting drum retainer ① as shown.
- Apply SUZUKI SUPER GREASE to the contacting surface between the rear wheel and the sprocket drum.

 **99000-25030: SUZUKI SUPER GREASE "A" (USA)  
99000-25010: SUZUKI SUPER GREASE "A" (Others)**

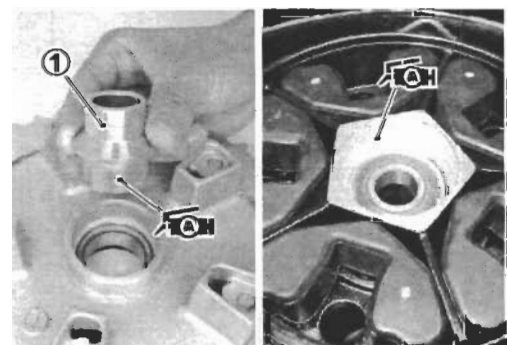

- Install the rear sprocket mounting drum assembly to the rear wheel hub.
- Tighten the sprocket mounting nuts to the specified torque.

**🔩 Rear sprocket nut: 60 N·m (6.0 kgf-m, 43.5 lb-ft)**

- Install the collar.

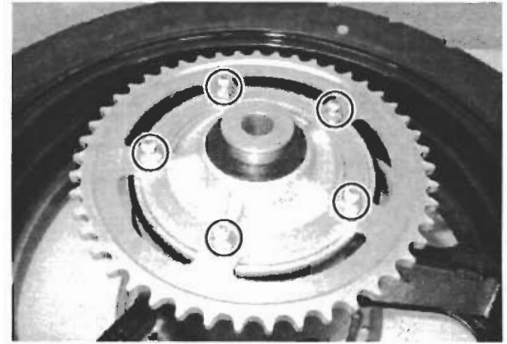

### REAR AXLE

- Remount the rear wheel and rear axle, install the washer and rear axle nut.
- Adjust the chain slack after rear wheel installation. (👉 2-21)
- Tighten the rear axle nut to the specified torque.

**🔩 Rear axle nut: 100 N·m (10.0 kgf-m, 72.5 lb-ft)**

- Install the new cotter pin. (For E-03, 28, 33)

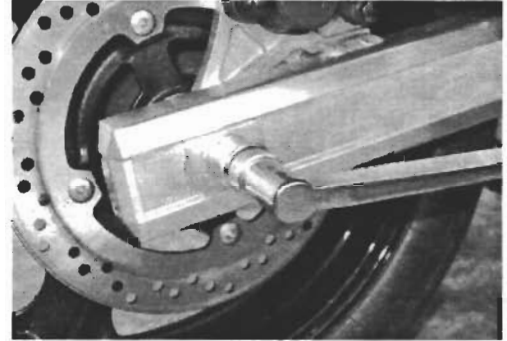

# REAR SHOCK ABSORBER CONSTRUCTION

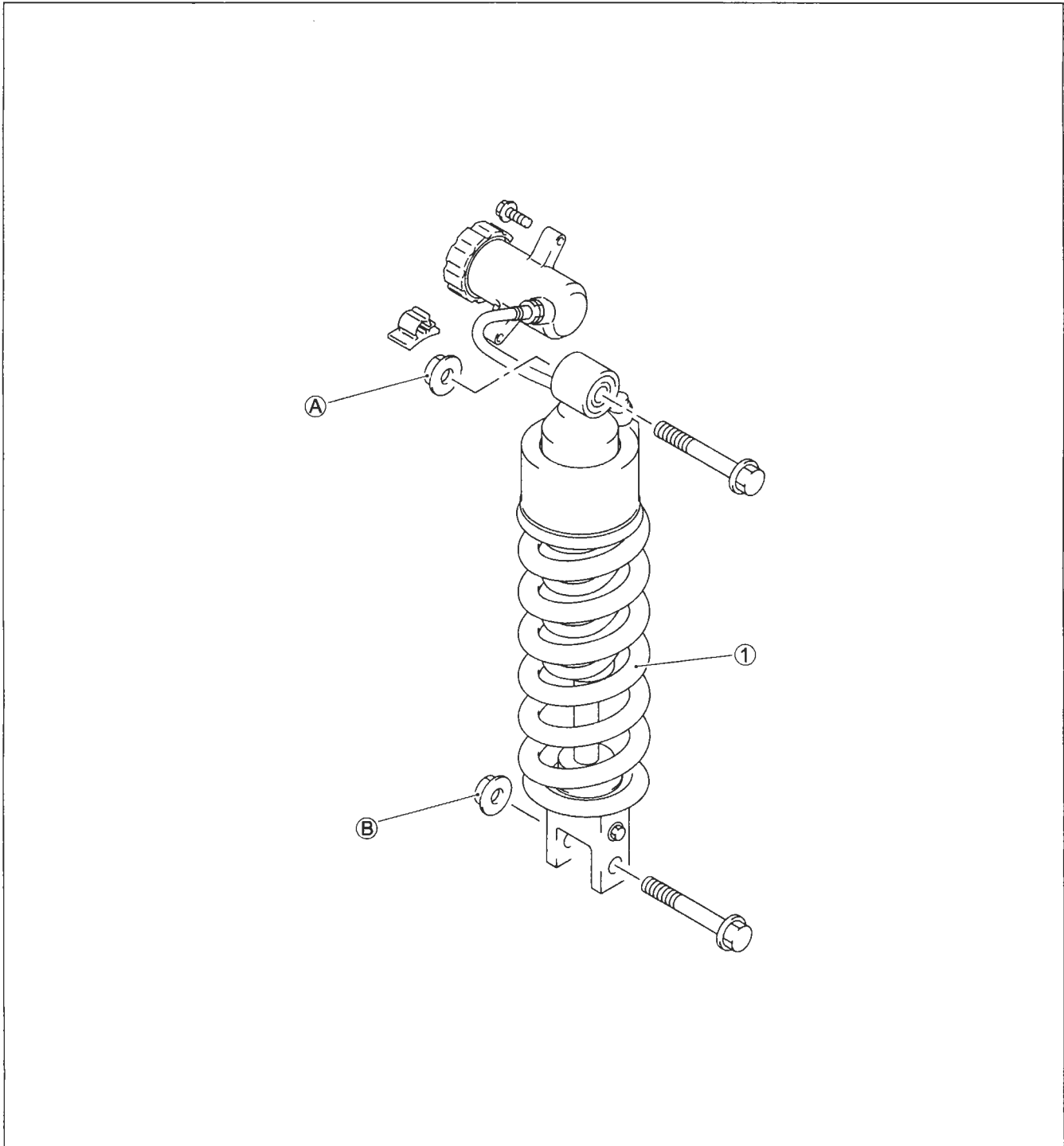

①	Rear shock absorber	Ⓑ	Rear shock absorber lower mounting nut
Ⓐ	Rear shock absorber upper mounting nut		

ITEM	N·m	kgf·m	lb·ft
Ⓐ	50	5.0	36.0
Ⓑ	50	5.0	36.0

## REMOVAL

- Raise the rear wheel off the ground and support the motorcycle with a jack or wooden block.
- Remove the pre-load adjuster ①.

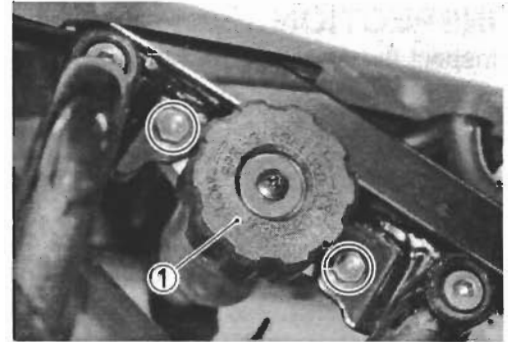

- Remove the cushion lever rod bolts/nuts and the cushion rods ②.

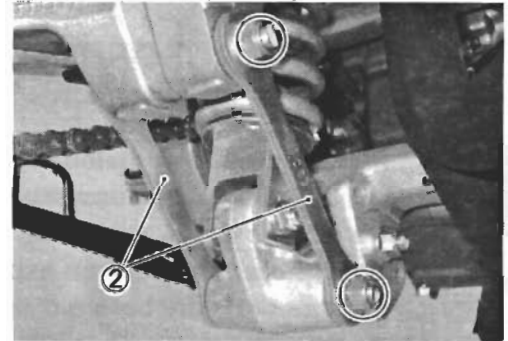

- Disconnect the pre-load adjuster hose from the clamp ③.
- Remove the rear shock absorber upper mounting bolt ④.

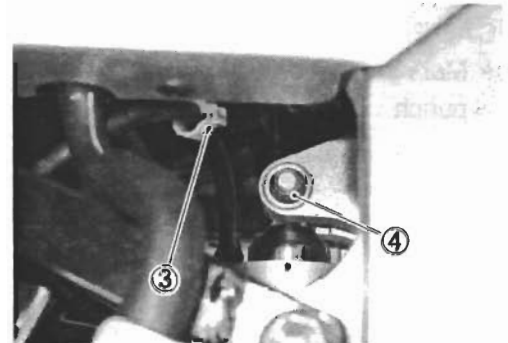

- Remove the rear shock absorber lower mounting bolt ⑤.

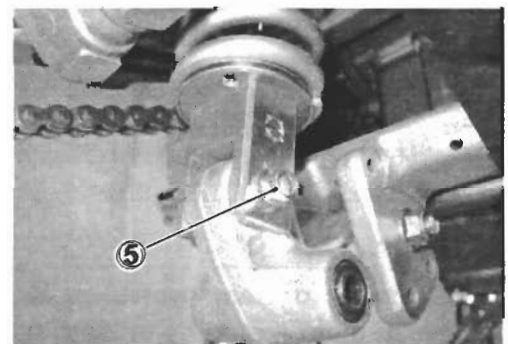

- Remove the rear shock absorber ⑥.

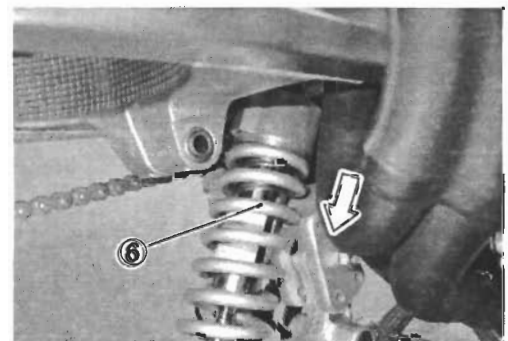

## INSPECTION

Inspect the shock absorber body and bushing for damage and oil leakage.

If any defects are found, replace the shock absorber with a new one.

### CAUTION

Do not attempt to disassemble the rear shock absorber unit. It is unserviceable.

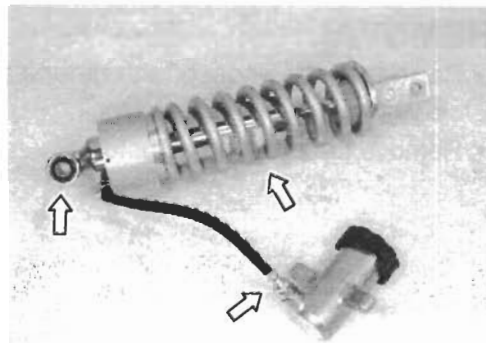

## REAR SHOCK ABSORBER DISPOSAL

### WARNING

- \* The rear shock unit contains high-pressure nitrogen gas. Mishandling can cause explosion.
- \* Keep away from fire and heat. High gas pressure caused by heat can cause an explosion.
- \* Release gas pressure before disposing.

### GAS PRESSURE RELEASE

- Mark the drill hole at (A), shown in the illustration, with a center punch.

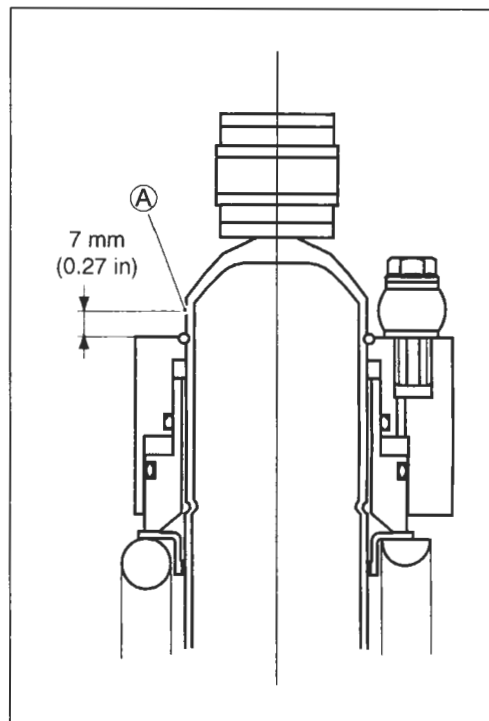

- Cover the rear shock absorber with a transparent vinyl bag ①.
- Hold the rear shock absorber ② with a vice.
- Make a hole with a 3 mm drill.

### WARNING

- \* Be sure to wear protective glasses since drilling chips and oil may fly off with blowing gas when the drill bit has penetrated through the body.
- \* Make sure to drill at the specified position. Otherwise, pressurized oil may spout out forcefully.

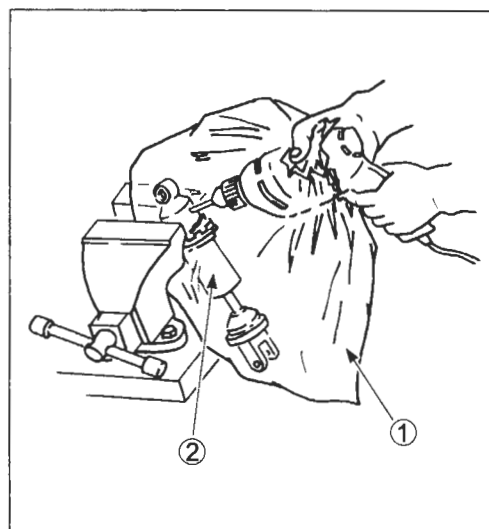

## REMountING

Remount the rear shock absorbers in the reverse order of removal. Pay attention to the following points:

- Install the rear shock absorber and tighten the rear shock absorber upper/lower mounting nuts.

**🔩 Rear shock absorber lower mounting nut:**  
50 N·m (5.0 kgf-m, 36.0 lb-ft)

**Rear shock absorber upper mounting nut:**  
50 N·m (5.0 kgf-m, 36.0 lb-ft)

### NOTE:

When installing the rear shock absorber, the outlet hose of the pre-load adjuster faces backward.

- Clamp the pre-load adjuster hose ①.

- Install the cushion rod ②.
- Tighten the cushion rod nuts to the specified torque.

**🔩 Cushion rod nut: 78 N·m (7.8 kgf-m, 56.5 lb-ft)**

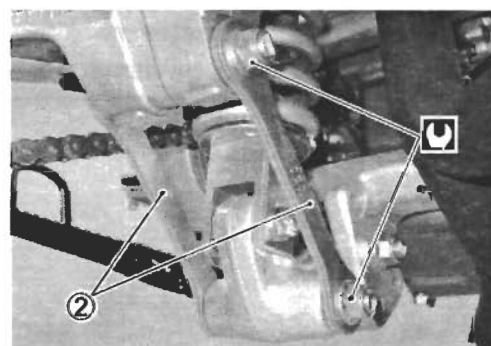
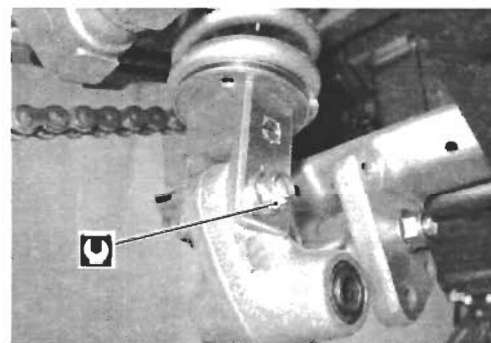
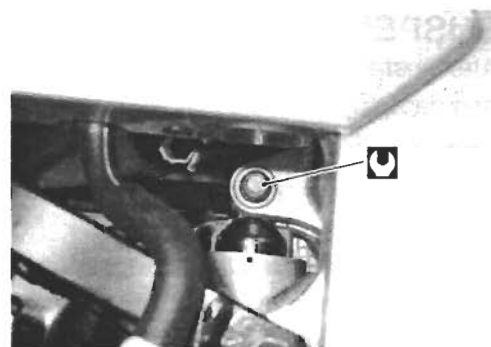

## SUSPENSION SETTING

After installing the rear suspension, adjust the spring pre-load and damping force as follows.

### SPRING PRE-LOAD ADJUSTMENT

The pre-load is adjusted by turning the pre-load adjuster knob without tool.

Position "0" provides the softest spring pre-load.

Position "5" provides the stiffest spring pre-load.

**STD position: "2"**

- Ⓐ STD position
- Ⓑ Stiffest position
- Ⓒ Softest position

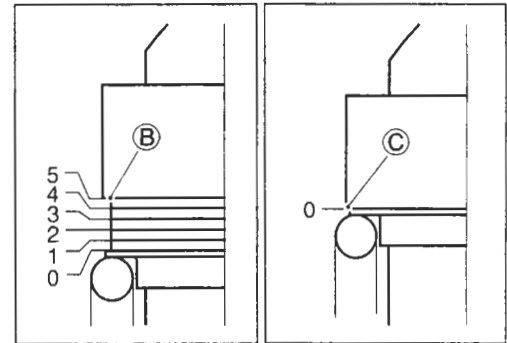
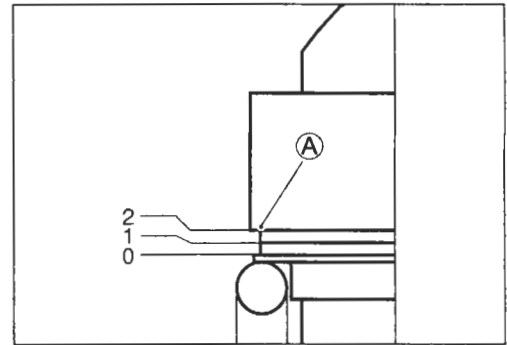

### DAMPING FORCE ADJUSTMENT

The rebound damping force is adjusted by turning the adjuster. Fully turn the damping adjuster ① clockwise. It is at stiffest position and turn it out to standard setting position.

**STD position: 1 turn back from stiffest position**

(E-02, 19, 24)

**1 1/2 turns back from stiffest position**

(E-03, 28, 33)

### CAUTION

Do not turn the adjuster more than the given position or the adjuster may be damaged.

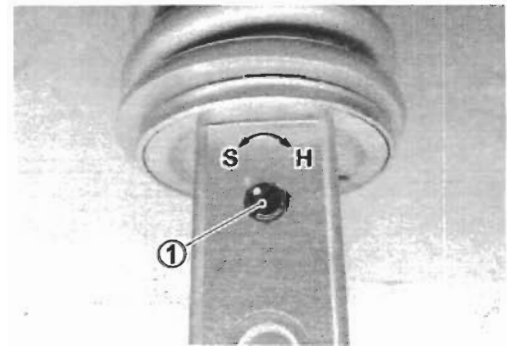

# REAR SWINGARM CONSTRUCTION

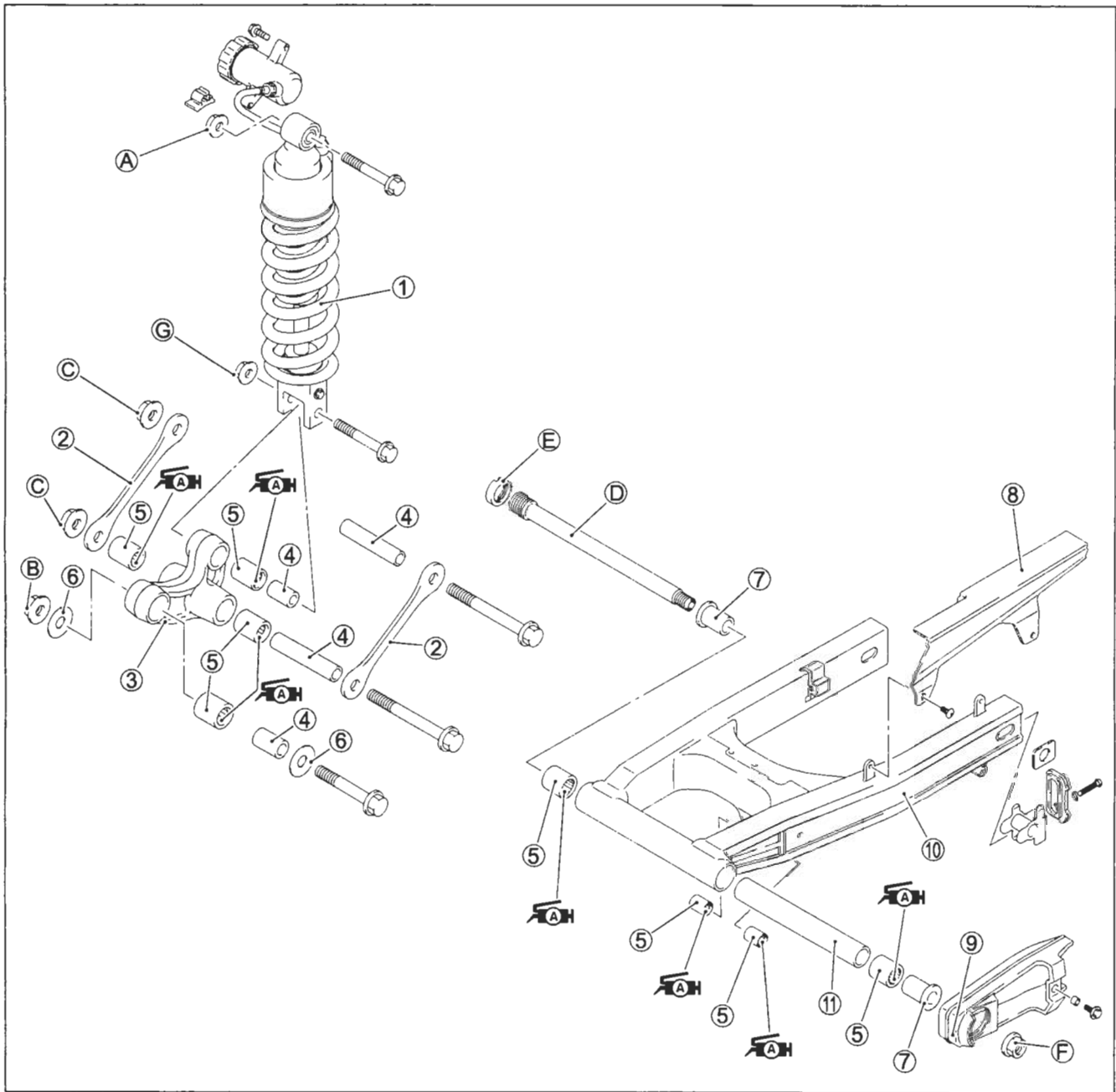

①	Rear shock absorber	⑩	Swingarm
②	Rear cushion rod	⑪	Center spacer
③	Rear cushion lever	A	Rear shock absorber upper mounting nut
④	Spacer	B	Cushion lever nut
⑤	Bearing	C	Cushion rod nut
⑥	Washer	D	Swingarm pivot shaft
⑦	Pivot spacer	E	Swingarm pivot lock-nut
⑧	Chain cover	F	Swingarm pivot nut
⑨	Chain buffer	G	Rear shock absorber lower mounting nut



ITEM	N-m	kgf-m	lb-ft
A	50	5.0	36.0
B	78	7.8	56.5
C	78	7.8	56.5
D	15	1.5	11.0
E	90	9.0	65.0
F	100	10.0	72.5
G	50	5.0	36.0



## REMOVAL

- Remove the exhaust pipe and exhaust muffler. (☞ 3-6)
- Raise the rear wheel off the ground and support the motorcycle with a jack or wooden block.
- Remove the rear wheel. (☞ 7-36)
- Remove the rear brake hose guides ①.

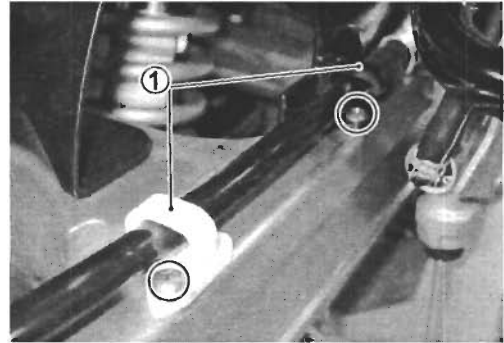

- Remove the cushion rods ②.
- Remove the shock absorber lower mounting bolt ③.
- Remove the cushion lever ④.

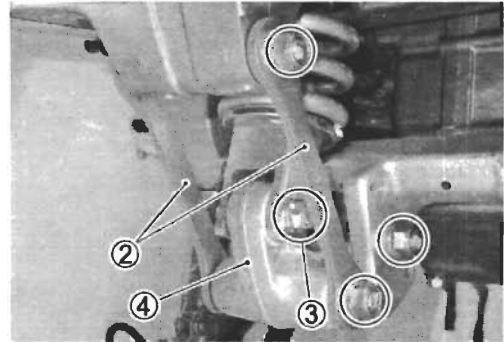

- Remove the swingarm pivot shaft lock-nut with the special tool.

**TOOL** 09940-14940: Swingarm pivot thrust adjuster socket wrench

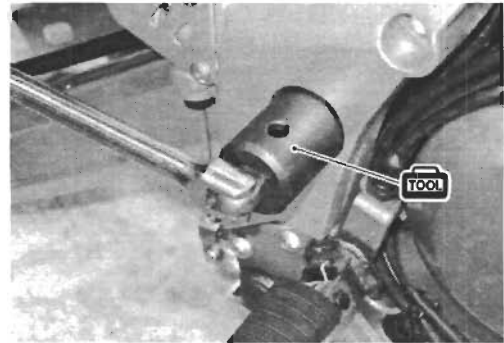

- Hold the swingarm pivot shaft ⑤ and remove the swingarm pivot nut ⑥.
- Remove the swingarm pivot shaft with the special tool.

**TOOL** 09944-28320: Hexagon bit 19 mm

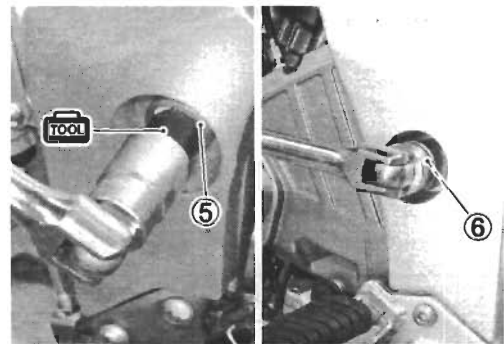

- Remove the chain cover ⑦.

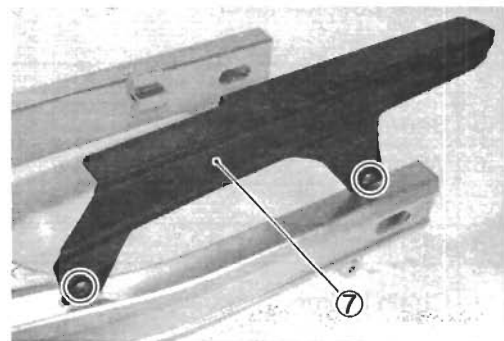

- Remove the mud guard ⑧.

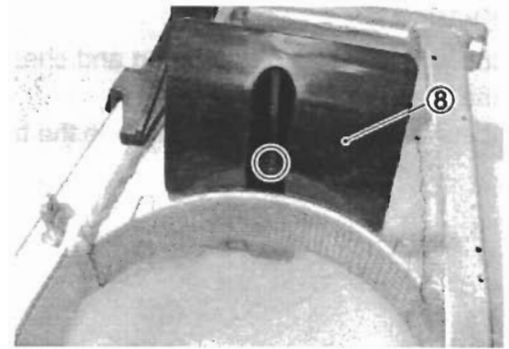

- Remove the chain buffer ⑨.

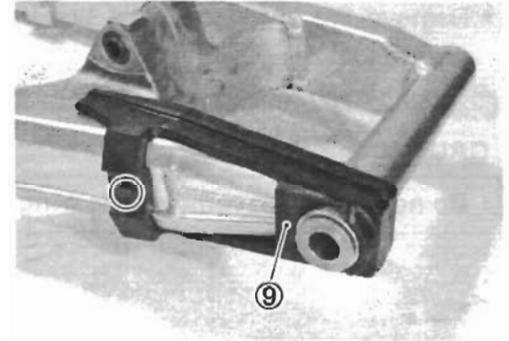

## INSPECTION AND DISASSEMBLY

### SPACER

- Remove the spacers ① from swingarm and cushion lever.
- Inspect the spacers for any flaws or other damage. If any defect is found, replace the spacers with the new ones.

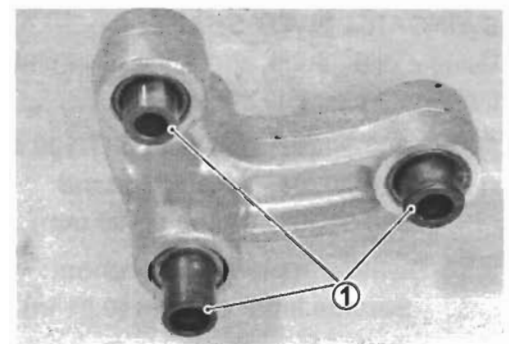
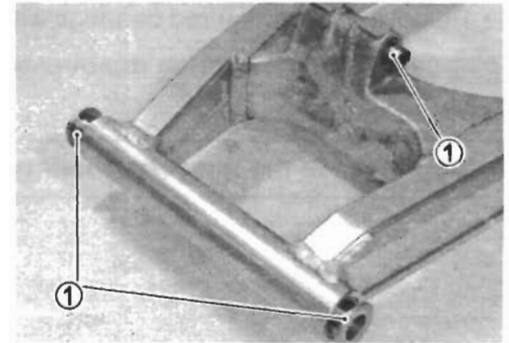

### CHAIN BUFFER

Inspect the chain buffer for damage and excessive wear. If any defect is found, replace the chain buffer with a new one.

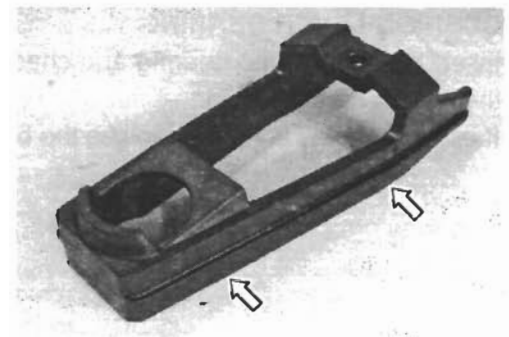

**SWINGARM BEARING**

Insert the spacer into bearing and check the play when moving the spacer up and down.

If excessive play is noted, replace the bearing with a new one.

- Remove the swingarm pivot bearings and spacer with the special tool.

**TOOL** 09921-20240: Bearing remover set (25 mm)

**CAUTION**

Do not reuse the removed bearings.

- Remove the cushion rod bearings with the special tool.

**TOOL** 09921-20240: Bearing remover set (17 mm)

**CAUTION**

Do not reuse the removed bearings.

**SWINGARM PIVOT SHAFT**

Using a dial gauge, check the pivot shaft runout and replace it if the runout exceeds the limit.

**TOOL** 09900-20607: Dial gauge (1/100 mm, 10 mm)

09900-20701: Magnetic stand

09900-21304: V-block (100 mm)

**DATA** Swingarm pivot shaft runout:  
Service limit: 0.3 mm (0.01 in)

**CUSHION LEVER BEARING**

Insert the spacer into bearing and check the play when moving the spacer up and down.

If excessive play is noted, replace the bearing with a new one.

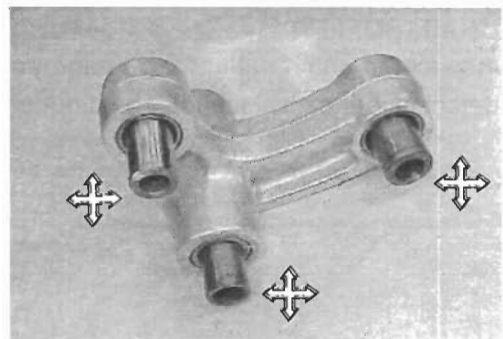
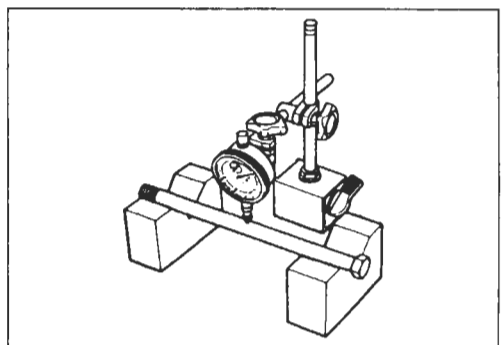
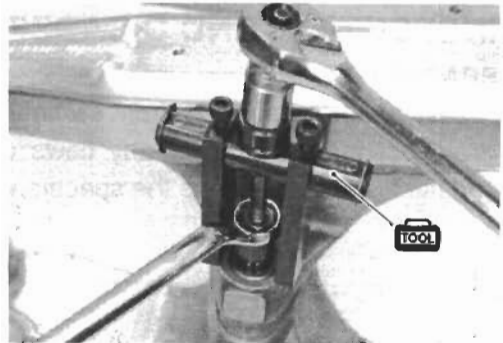
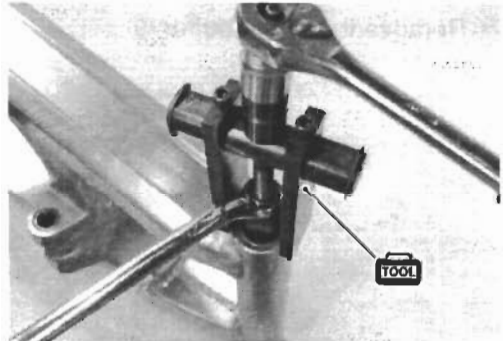
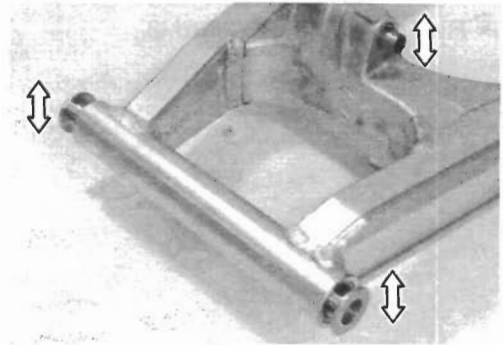

- Remove the cushion lever bearings with the special tool.

 09921-20240: Bearing remover set (20 mm and 17 mm)

**CAUTION**

The removed bearings must be replaced with the new ones.

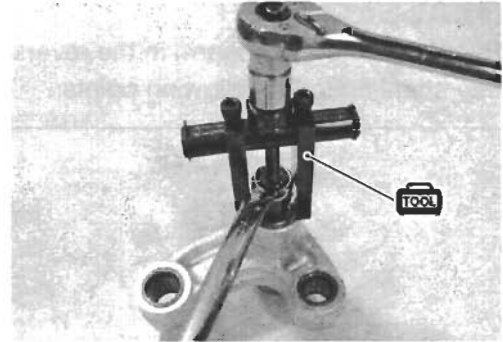

**CUSHION ROD**

Inspect the cushion rods for damage and distortion.

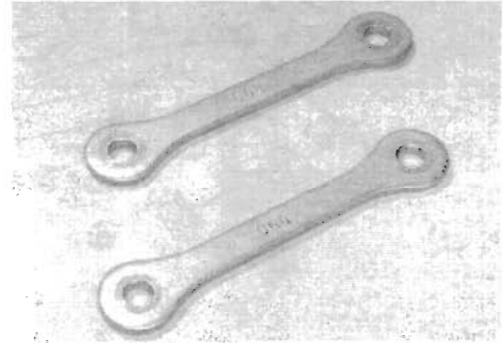

## REASSEMBLY

Reassemble the swingarm in the reverse order of disassembly and removal.  
Pay attention to the following points:

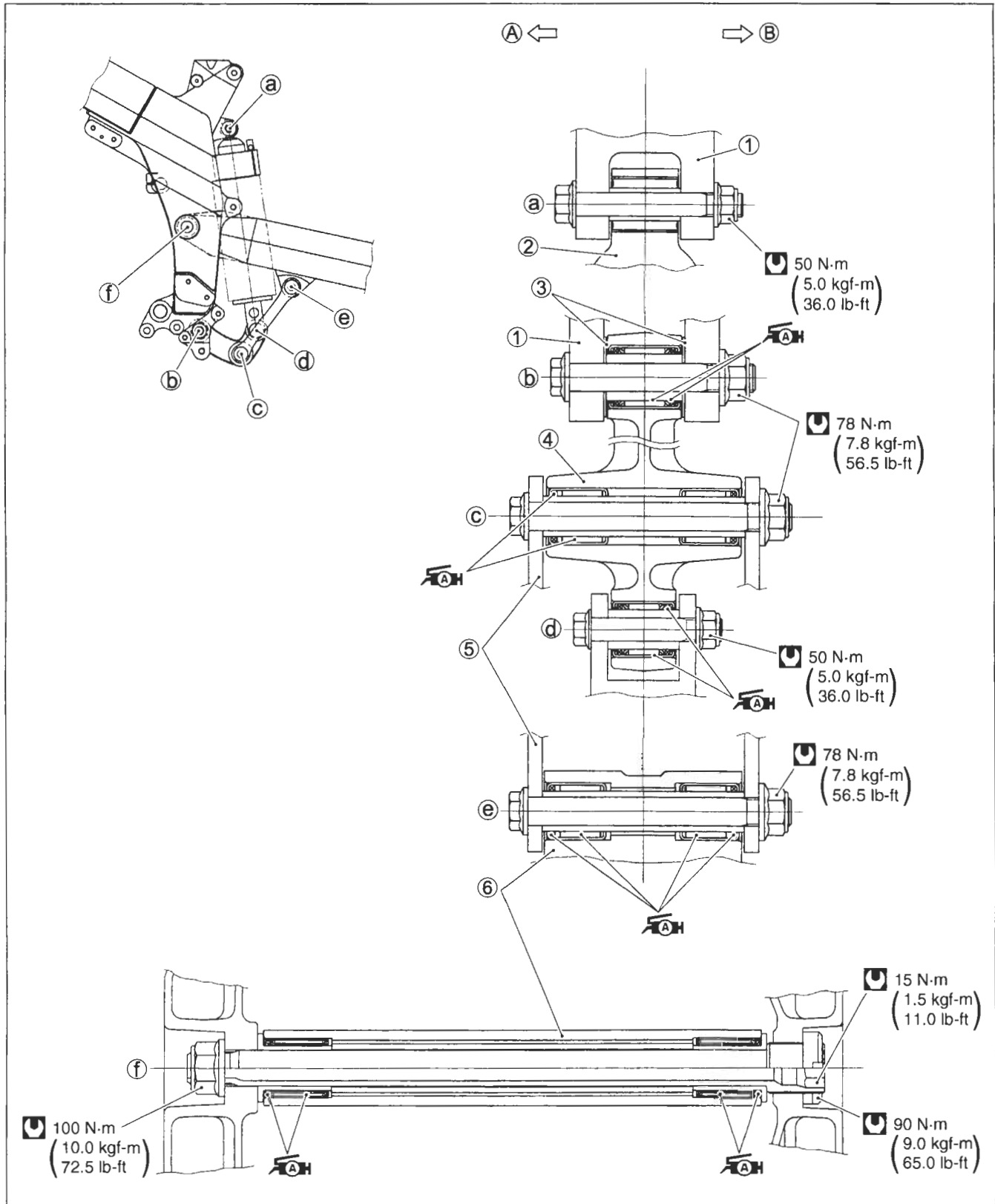

- ① Frame    ② Rear shock absorber    ③ Washer    ④ Cushion lever    ⑤ Cushion rod
- ⑥ Swingarm    A Left    B Right

**SWINGARM BEARING**

- Install the bearings and spacer into the swingarm pivot all together with the special tools.

 **09941-34513: Steering race installer**  
**09913-70210: Bearing installer set ( $\phi$  32)**

**NOTE:**

*When installing the bearing, the stamped mark on the bearing must face the special tool.*

- Install the cushion rod bearings with the special tool.

 **09941-34513: Steering race installer**

**NOTE:**

*When installing the bearing, the dust seal that is embedded in the bearing must face outside.*

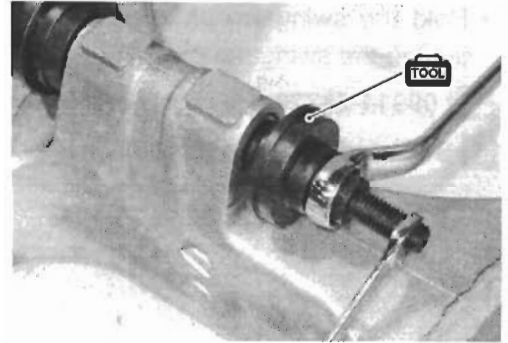
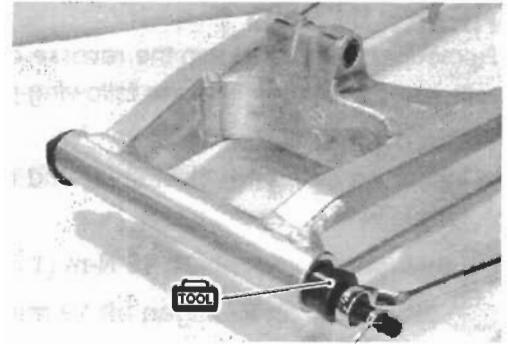
**CUSHION LEVER BEARING**

- Press the bearings into the cushion lever with the special tool.

 **09941-34513: Steering race installer**

**NOTE:**

*When installing the bearing, the dust seal that is embedded in the bearing must face outside.*

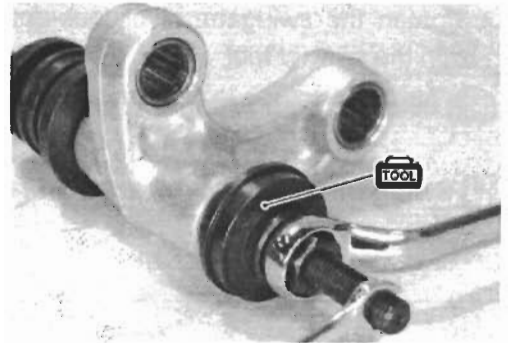

- Apply SUZUKI SUPER GREASE to the bearings and spacers.

 **99000-25030: SUZUKI SUPER GREASE "A" (USA)**  
**99000-25010: SUZUKI SUPER GREASE "A" (Others)**

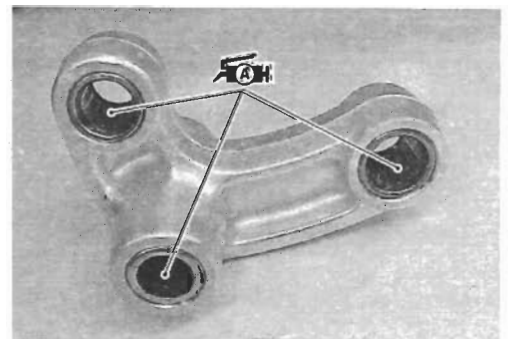
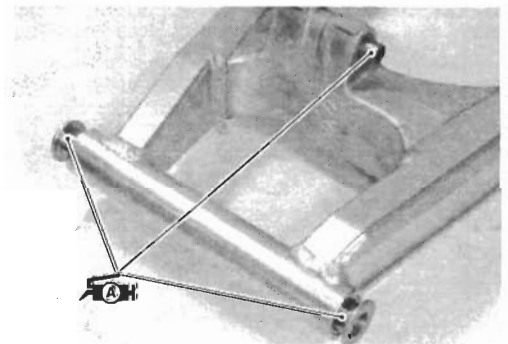

## REMOUNTING

Remount the swingarm in the reverse order of disassembly and removal. Pay attention to the following points:

### SWINGARM

- Insert the swingarm pivot shaft and tighten it to the specified torque with the special tool.

 **Swingarm pivot shaft: 15 N·m (1.5 kgf-m, 11.0 lb-ft)**

 **09944-28320: Hexagon bit 19 mm**

- Hold the swingarm pivot shaft ① with the special tool and tighten the swingarm pivot nut ② to the specified torque.

 **09944-28320: Hexagon bit 19 mm**

 **Swingarm pivot nut: 100 N·m (10.0 kgf-m, 72.5 lb-ft)**

- Tighten the swingarm pivot lock-nut to the specified torque with the special tool.

 **09940-14940: Swingarm pivot thrust adjuster socket wrench**

 **Swingarm pivot lock-nut: 90 N·m (9.0 kgf-m, 65.0 lb-ft)**

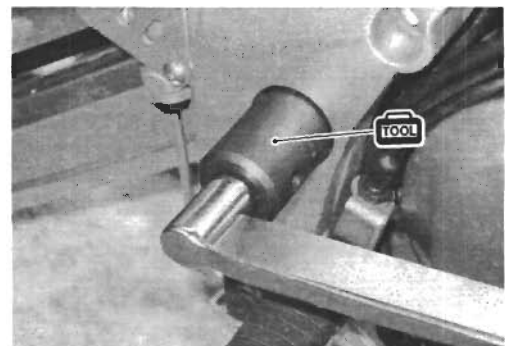
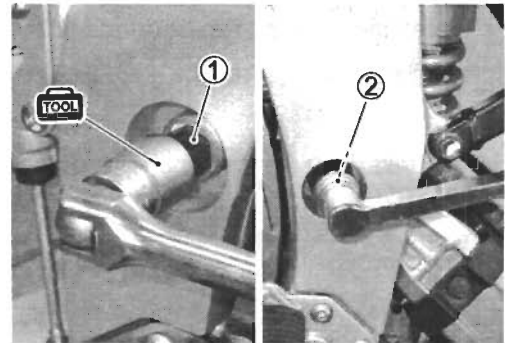
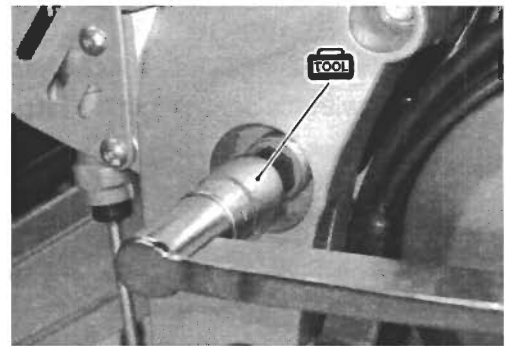

### CUSHION LEVER AND CUSHION ROD

- Install the washers ① and cushion lever ②.

#### NOTE:

Insert the cushion lever mounting bolt from the left side.  
( 7-54)

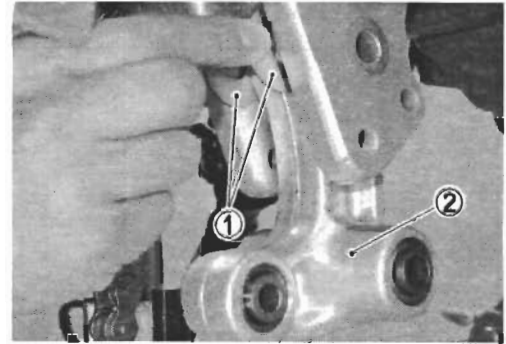

- Install the cushion rod and rear shock absorber.

#### NOTE:

Insert the cushion rod mounting bolts and rear shock absorber mounting bolts from the left side. ( 7-54)

- Tighten the cushion lever nut ③, cushion rod nut ④ and rear shock absorber lower mounting nut ⑤ to the specified torque.



 **Cushion lever nut: 78 N·m (7.8 kgf-m, 56.5 lb-ft)**

**Cushion rod nut: 78 N·m (7.8 kgf-m, 56.5 lb-ft)**

**Rear shock absorber lower mounting nut:**

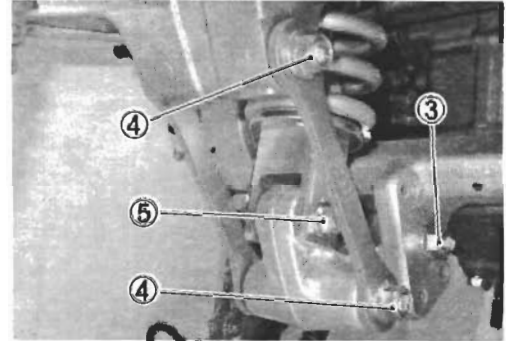

**50 N·m (5.0 kgf-m, 36.0 lb-ft)**



- Install the rear wheel. ( 7-40)
- Install the exhaust pipe and muffler. ( 3-14)

### FINAL INSPECTION AND ADJUSTMENT

After installing the rear suspension and wheel, the following adjustments are required before driving.

- \* Drive chain: ( 2-21)
- \* Tire pressure: ( 7-82)
- \* Chassis bolts and nuts: ( 2-28)



# FRONT BRAKE CONSTRUCTION

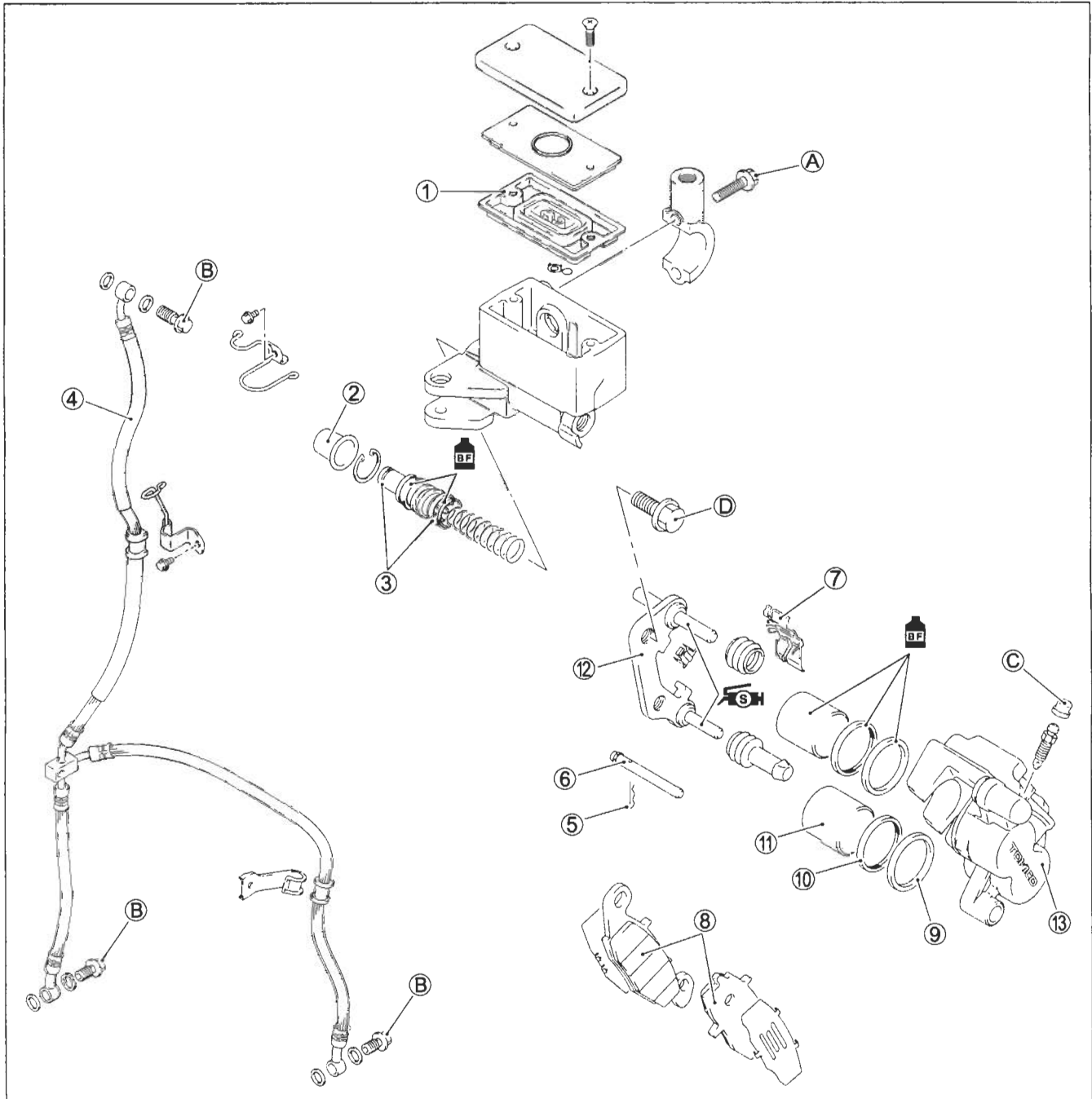

① Diaphragm	⑩ Dust seal
② Dust boot	⑪ Piston
③ Piston/cup set	⑫ Caliper holder
④ Brake hose	⑬ Caliper
⑤ Pin	A Front brake master cylinder mounting bolt
⑥ Pad mounting pin	B Brake hose union bolt
⑦ Brake pad spring	C Air bleeder valve
⑧ Brake pad	D Brake caliper mounting bolt
⑨ Piston seal	

ITEM	N-m	kgf-m	lb-ft
A	10	1.0	7.0
B	23	2.3	16.5
C	7.5	0.75	5.5
D	39	3.9	28.0

**⚠ WARNING**

- \* This brake system is filled with an ethylene glycol-based DOT 4 brake fluid. Do not use mix different types of fluid such as silicone-based or petroleum-based.
- \* Do not use any brake fluid taken from old, used or unsealed containers. Never reuse brake fluid left over from the last servicing or stored for long periods.
- \* When storing the brake fluid, seal the container completely and keep away from children.
- \* When replenishing brake fluid, take care not to get dust into fluid.
- \* When washing brake components, use fresh brake fluid. Never use cleaning solvent.
- \* A contaminated brake disc or brake pad reduces braking performance. Discard contaminated pads and clean the disc with high quality brake cleaner or neutral detergent.

**CAUTION**

Handle brake fluid with care: the fluid reacts chemically with paint, plastics, rubber materials etc. and will damage them severely.

**BRAKE PAD REPLACEMENT**

- Remove the caliper.

**CAUTION**

Do not operate the brake lever while removing the caliper.

- Remove the pin ①.
- Remove the brake pads by removing the pad mounting pin ②.
- Clean up the caliper especially around the caliper pistons.

- Install the outer pad with the detent (A) of pad fitted to the detent (B) on the caliper holder.

**CAUTION**

Replace the brake pads as a set, otherwise braking performance will be adversely affected.

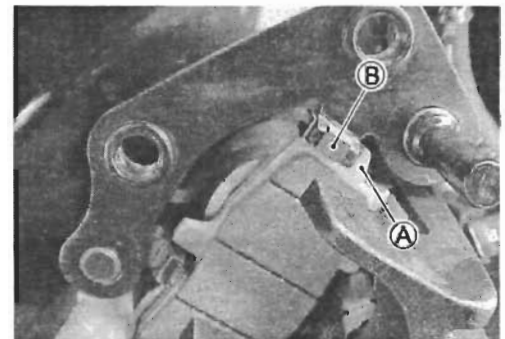
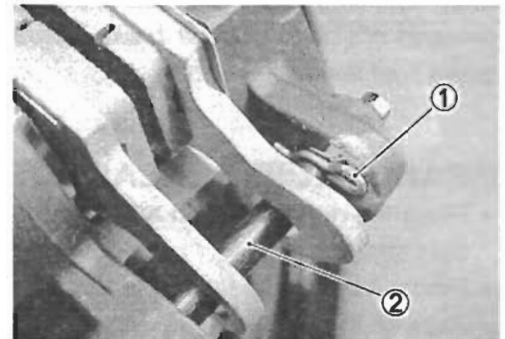
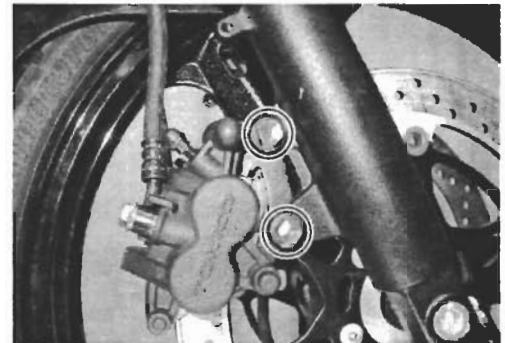

- Install the inner pad so that the inner pad will be seated on the hatched part ③.

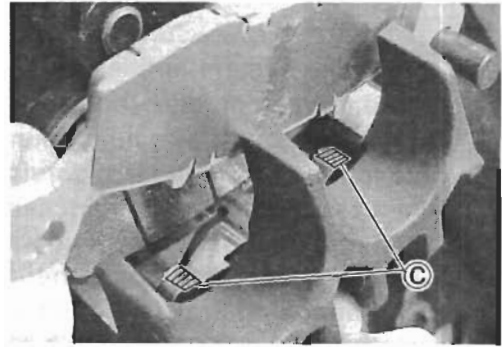

- Install the pad mounting pin ③.
- Install the pin ④ securely.

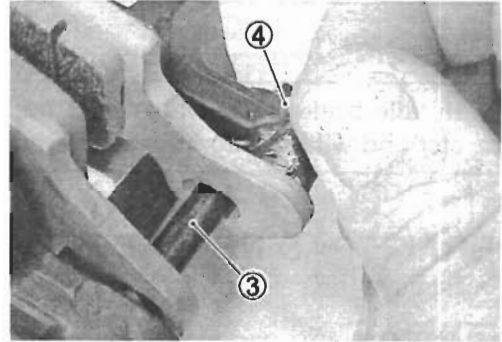

- Install the caliper.
- Tighten the caliper mounting bolts to the specified torque.

**Front brake caliper mounting bolt:**  
**39 N·m (3.9 kgf·m, 28.0 lb·ft)**

**NOTE:**

*After replacing the brake pads, pump the brake lever several times to check for proper brake operation and then check the brake fluid level.*

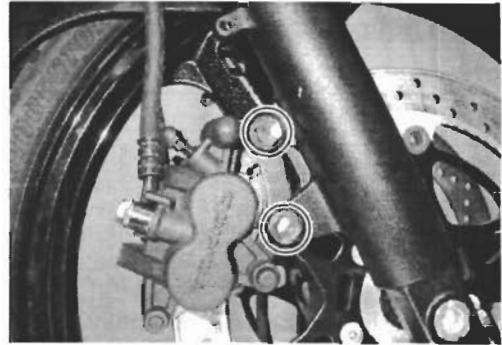

## BRAKE FLUID REPLACEMENT

- Place the motorcycle on a level surface and keep the handlebars straight.
- Remove the brake fluid reservoir cap and diaphragm.
- Suck up the old brake fluid as much as possible.
- Fill the reservoir with the new brake fluid.

**Specification and Classification: DOT 4**

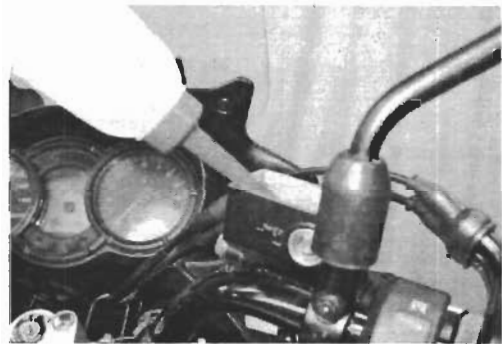

- Connect a clear hose to the caliper air bleeder valve and insert the other end of hose into a receptacle.
- Loosen the air bleeder valve and pump the brake lever until old brake fluid flows out of the bleeder system.
- Close the caliper air bleeder valve and disconnect a clear hose. Fill the reservoir with the new fluid to the upper mark of the reservoir.

**Brake air bleeder valve: 7.5 N·m (0.75 kgf·m, 5.5 lb·ft)**

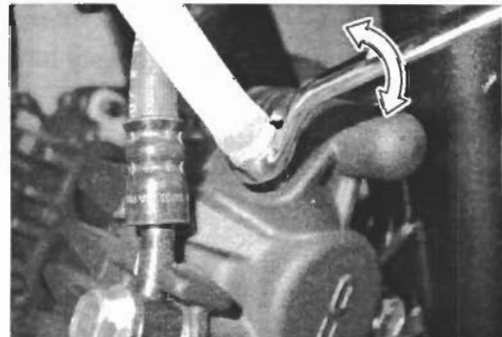

**CAUTION**

- \* Never reuse the brake fluid left over from previous servicing and which has been stored for long periods of time.
- \* Bleed air from the brake system. (☞ 2-25)

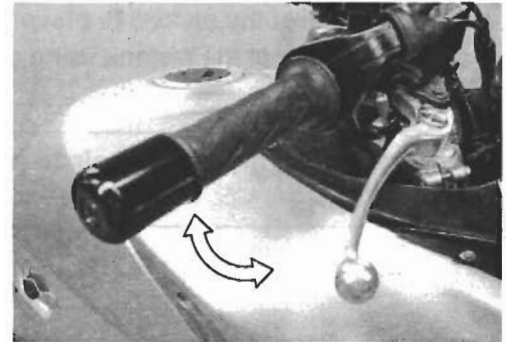
**CALIPER REMOVAL AND DISASSEMBLY**

- Drain the brake fluid. (☞ 7-60)
- Remove the brake pads. (☞ 7-59)
- Disconnect the brake hoses by removing the brake hose union bolts.

**NOTE:**

Place a rag underneath the union bolt on the brake caliper to catch any spilt brake fluid.

- Remove the brake calipers by removing the caliper mounting bolts.

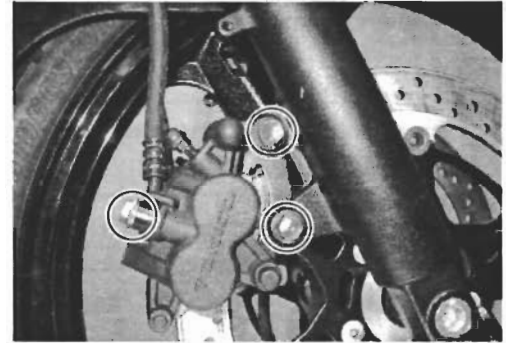
**CAUTION**

Do not reuse the brake fluid left over from previous servicing and stored for long periods of time.

**⚠ WARNING**

Brake fluid, if it leaks, will interfere with safe running and discolor painted surfaces. Check the brake hose and hose joints for cracks and fluid leakage.

- Remove the caliper holder ①.
- Remove the pad spring ②.

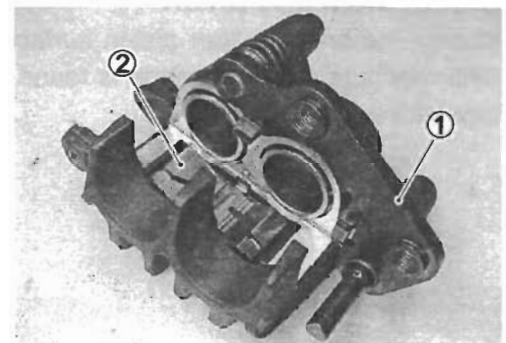

- Place a rag over the pistons to prevent them from popping out and then force out the pistons using compressed air.

**CAUTION**

Do not use high pressure air to prevent piston damage.

- Remove the dust seals ③ and piston seals ④.

**CAUTION**

Do not reuse the removed dust seals and piston seals to prevent fluid leakage.

**CALIPER INSPECTION****BRAKE CALIPER**

Inspect the brake caliper cylinder wall for nicks, scratches and other damage. If any damage is found, replace the caliper with a new one.

**BRAKE CALIPER PISTON**

Inspect the brake caliper piston surface for any scratches and other damage. If any damage is found, replace the caliper pistons with the new ones.

**CALIPER HOLDER**

Inspect the caliper holder for damage. If any damage is found, replace it with a new one.

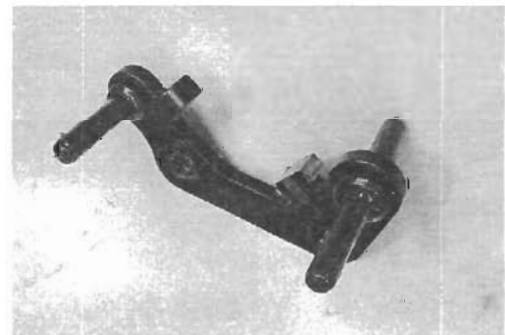
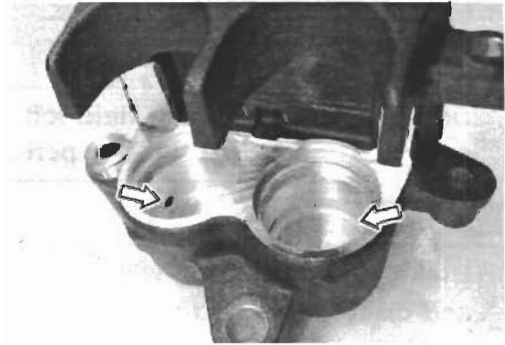
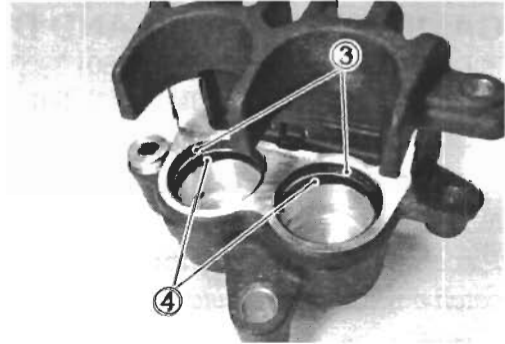

## RUBBER PARTS

Inspect the rubber parts for damage. If any damage is found, replace them with the new ones.



## CALIPER REASSEMBLY AND REMOUNTING

Reassemble and remount the caliper in the reverse order of removal and disassembly. Pay attention to the following points:

- Wash the caliper bores and pistons with specified brake fluid. Particularly wash the dust seal grooves and piston seal grooves.

 **Specification and Classification: DOT 4**

### CAUTION

- \* Wash the caliper components with fresh brake fluid before reassembly. Never use cleaning solvent or gasoline to wash them.
- \* Do not wipe the brake fluid off after washing the components with a rag.
- \* When washing the components, use the specified brake fluid. Never use different types of fluid or cleaning solvent such as gasoline, kerosine or the others.
- \* Replace the piston seals and dust seals with the new ones when reassembly.
- \* Apply the brake fluid to both seals when installing them.

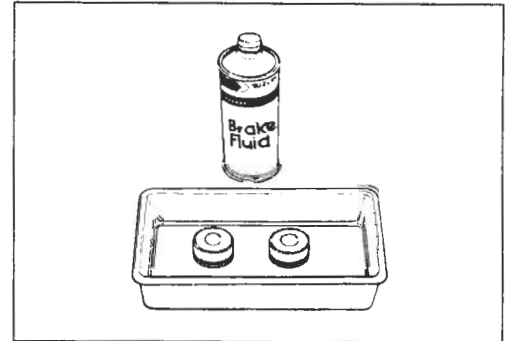

## PISTON SEAL

- Install the piston seals as shown in the illustration.
- Install the piston to the caliper.

- ① Dust seal
- ② Piston seal
- ③ Caliper

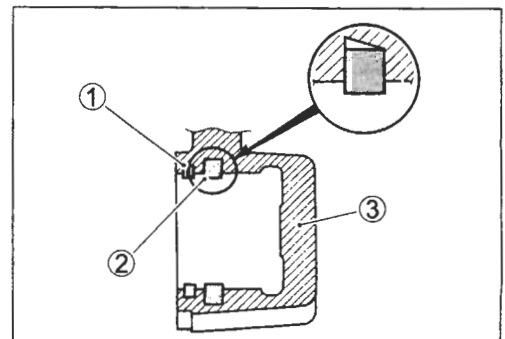

**CALIPER HOLDER**

- Apply SUZUKI SILICONE GREASE to the caliper holder pin.

 99000-25100: SUZUKI SILICONE GREASE

- Install the caliper holder to the caliper.

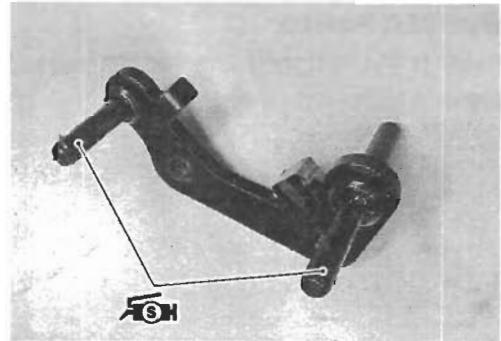

- Install the pad spring ①.

**NOTE:**

*When installing the pad spring, seated on the lug of pad spring to concaved part of brake caliper.*

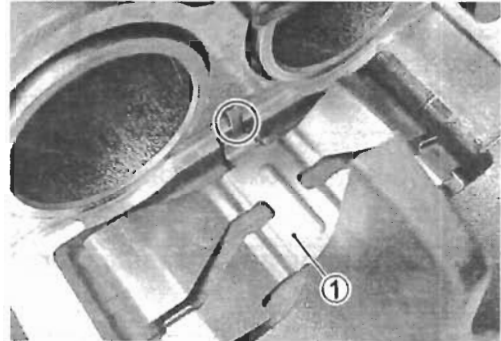

- Install the brake pads. ( 7-59)

**NOTE:**

*Before remounting the caliper, push the piston all the way into the caliper.*

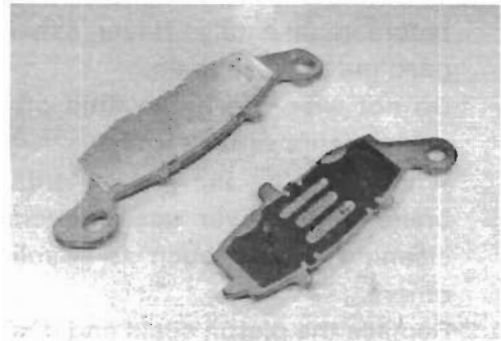

- Install the brake caliper to the front fork.
- Tighten each bolt to the specified torque.

 **Front brake caliper mounting bolt ②:**

**39 N·m (3.9 kgf-m, 28.0 lb-ft)**

**Front brake hose union bolt ③:**

**23 N·m (2.3 kgf-m, 16.5 lb-ft)**

**CAUTION**

\* The seal washers should be replaced with the new ones to prevent fluid leakage.

\* Bleed air from the system after reassembling the caliper. ( 2-25)

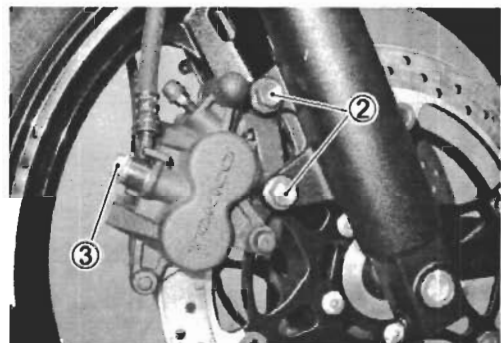

## BRAKE DISC INSPECTION

Visually check the brake disc for damage or cracks.

Measure the thickness with a micrometer.

Replace the disc if the thickness is less than the service limit or if damage is found.

**DATA** Front disc thickness: Service Limit: 4.5 mm (0.18 in)

**TOOL** 09900-20205: Micrometer (0 – 25 mm)

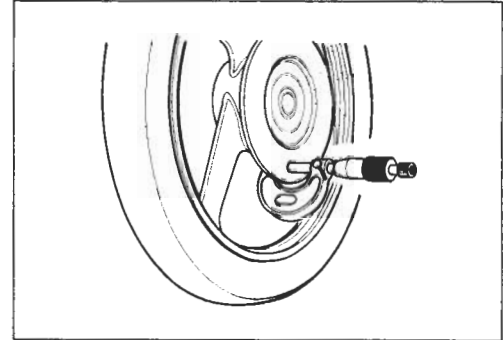

Measure the runout with a dial gauge.

Replace the disc if the runout exceeds the service limit.

**DATA** Front disc runout: Service Limit: 0.30 mm (0.012 in)

**TOOL** 09900-20607: Dial gauge (1/100 mm)  
09900-20701: Magnetic stand

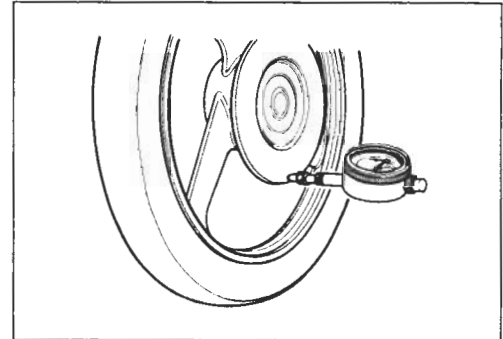

\* Brake disc removal (☞7-10)

\* Brake disc installation (☞7-14)

## MASTER CYLINDER REMOVAL AND DISASSEMBLY

- Remove the rear view mirror and brake lever cover.
- Drain the brake fluid. (☞7-60)
- Disconnect the front brake switch coupler ①.

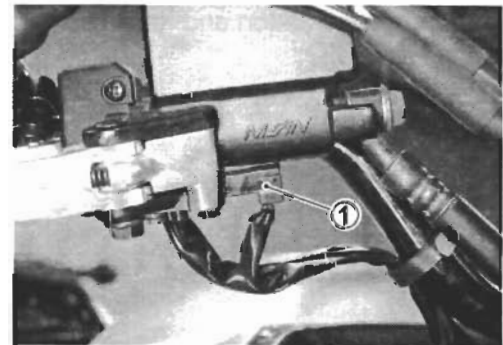

- Place a rag underneath the union bolt on the master cylinder to catch any spilt brake fluid. Remove the brake hose union bolt and disconnect the brake hose.

### CAUTION

Immediately and completely wipe off any brake fluid contacting any part of the motorcycle. The fluid reacts chemically with paint, plastics and rubber materials, etc. and will damage them severely.

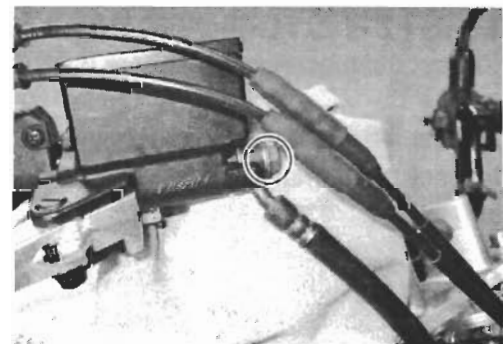

- Remove the master cylinder ②.

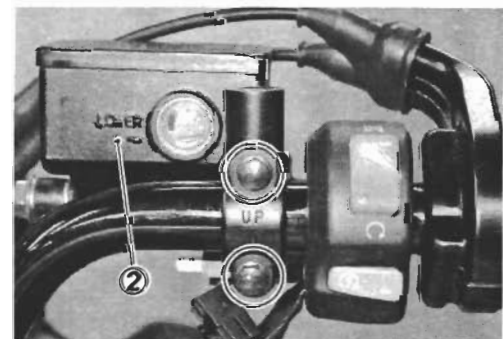



- Remove the brake lever ③ and brake switch ④.

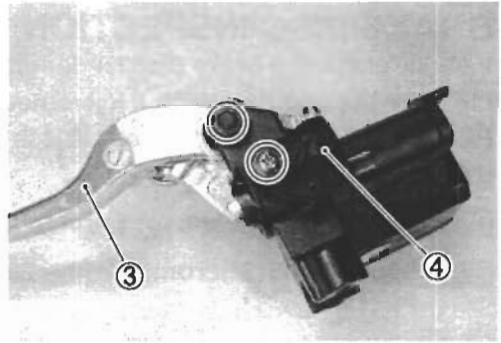

- Pull out the dust boot ⑤ and remove the snap ring ⑥.

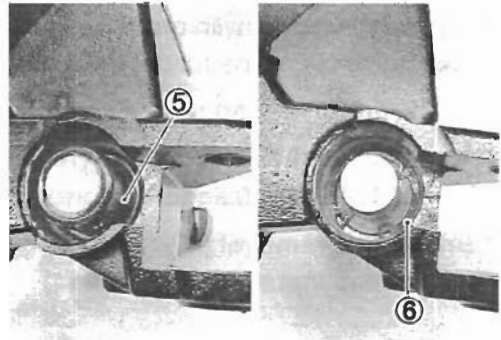

- Remove the piston and return spring.

- ⑦ Piston
- ⑧ Secondary cup
- ⑨ Primary cup
- ⑩ Return spring

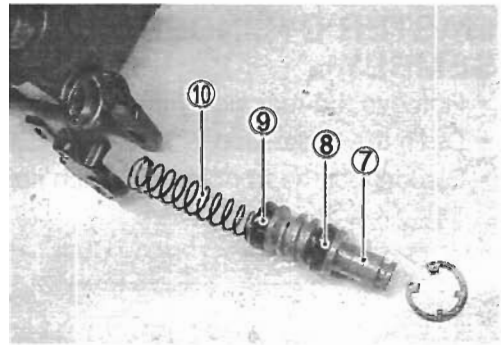

### MASTER CYLINDER INSPECTION

Inspect the master cylinder bore for any scratches or other damage.

Inspect the piston surface for any scratches or other damage.

Inspect the primary cup, secondary cup and dust seal for wear or damage.

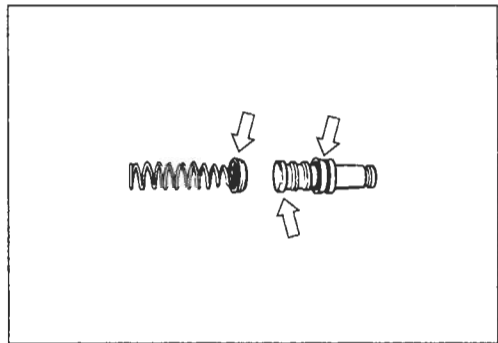

## MASTER CYLINDER REASSEMBLY AND REMOUNTING

Reassemble and remount the master cylinder in the reverse order of removal and disassembly. Pay attention to the following points:

### CAUTION

- \* Wash the master cylinder components with fresh brake fluid before reassembly. Never use cleaning solvent or gasoline to wash them.
- \* Do not wipe the components with a rag.
- \* Apply brake fluid to the cylinder bore and all the component to be inserted into the bore.

### Specification and Classification: DOT 4

- Apply brake fluid to the piston and cups.
- Install the following parts to the master cylinder.
  - ① Dust boot
  - ② Snap ring
  - ③ Secondary cup
  - ④ Piston
  - ⑤ Primary cup
  - ⑥ Return spring

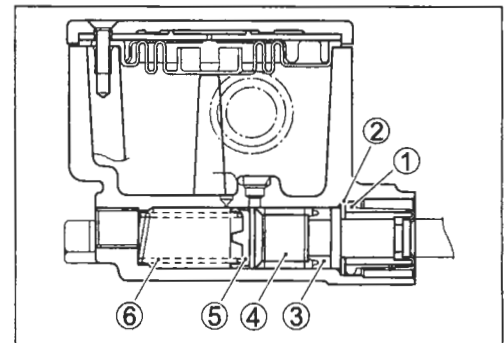
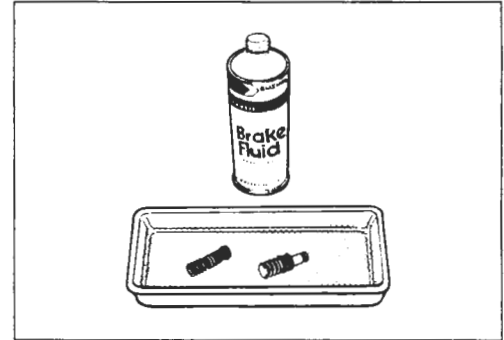

- When remounting the brake master cylinder ⑦ onto the handlebars, align the master cylinder holder's mating surface A with punch mark B on the handlebars ⑧ as shown.
- Tighten the front brake master cylinder mounting bolt to the specified torque and first tighten the upper mounting bolt.

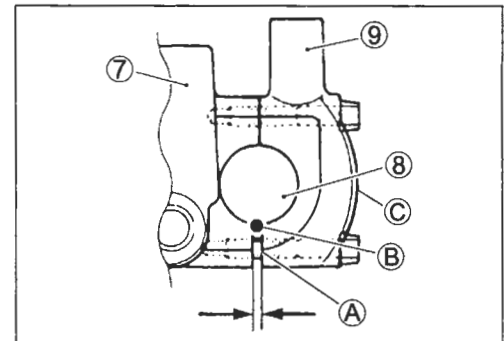

### Front brake master cylinder mounting bolt:

10 N·m (1.0 kgf-m, 7.0 lb-ft)

- ⑨ Master cylinder holder
- © "UP" mark

- Tighten the union bolt to the specified torque. (Brake hose routing:  9-26)

### Brake hose union bolt: 23 N·m (2.3 kgf-m, 16.5 lb-ft)

### CAUTION

- \* The seal washers should be replaced with the new ones to prevent fluid leakage.
- \* Bleed air from the system after reassembling the master cylinder. ( 2-25)

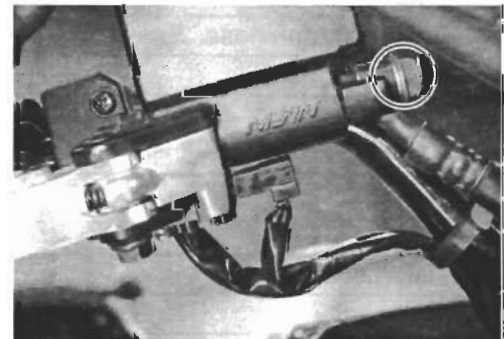

# REAR BRAKE CONSTRUCTION

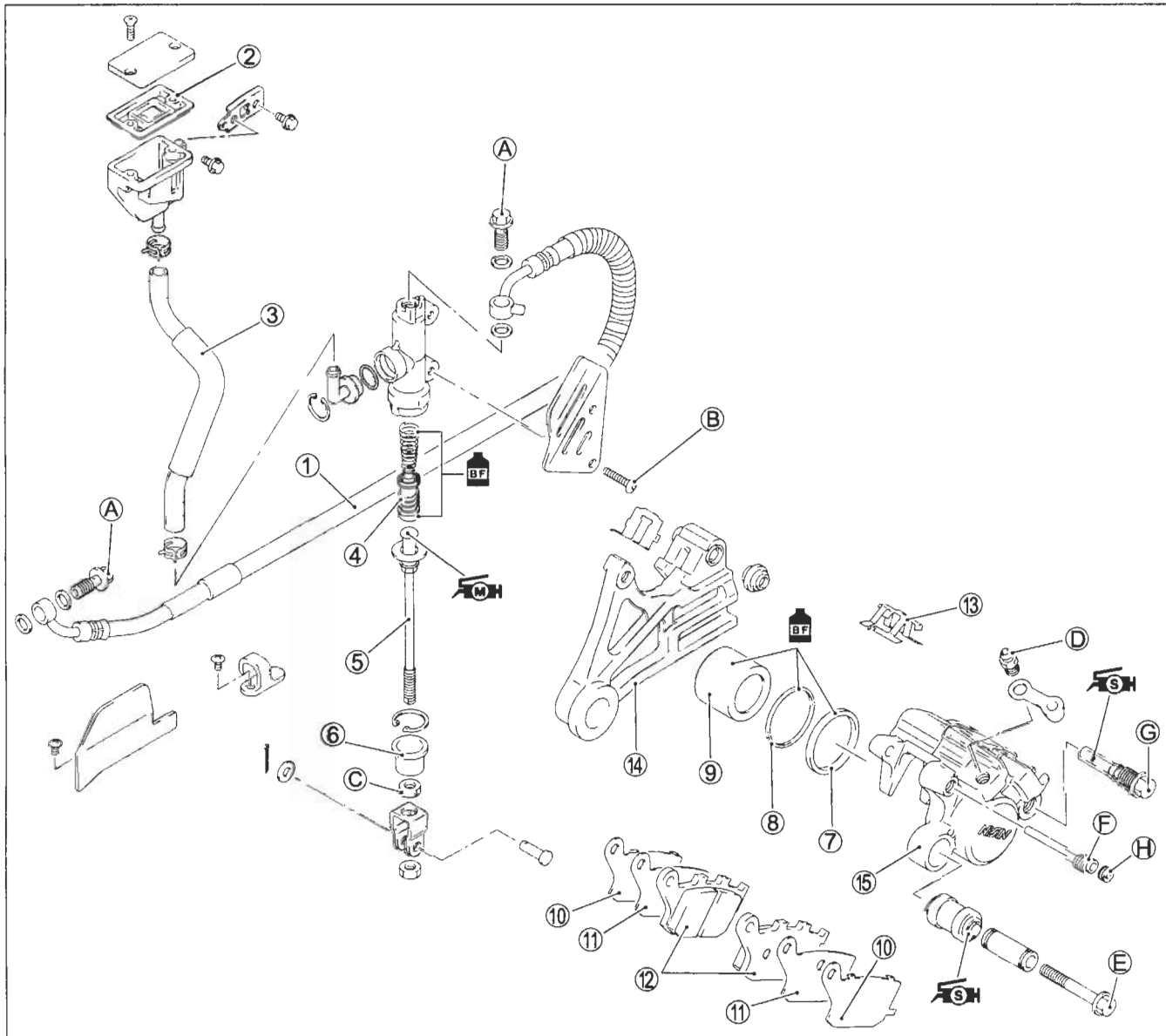

① Brake hose	⑬ Brake pad spring
② Diaphragm	⑭ Caliper bracket
③ Reservoir tank hose	⑮ Caliper
④ Piston/cup set	A Brake hose union bolt
⑤ Push rod	B Rear brake master cylinder mounting bolt
⑥ Dust boot	C Rear brake master cylinder rod lock-nut
⑦ Piston seal	D Air bleeder valve
⑧ Dust seal	E Brake caliper mounting bolt
⑨ Piston	F Pad mounting pin
⑩ Pad shim	G Brake caliper sliding pin
⑪ Pad insulator	H Plug
⑫ Brake pad	



ITEM	N-m	kgf-m	lb-ft
A	23	2.3	16.5
B	10	1.0	7.0
C	18	1.8	13.0
D	6	0.6	4.3
E	22	2.2	16.0
F	17	1.7	12.5
G	27	2.7	19.5
H	2.5	0.25	1.8

**▲ WARNING**

- \* This brake system is filled with an ethylene glycol-based DOT 4 brake fluid. Do not use or mix different types of fluid such as silicone-based or petroleum-based.
- \* Do not use any brake fluid taken from old, used or unsealed containers. Never reuse brake fluid left over from the last servicing or stored for long periods.
- \* When storing the brake fluid, seal the container completely and keep away from children.
- \* When replenishing brake fluid, take care not to get dust into fluid.
- \* When washing brake components, use fresh brake fluid. Never use cleaning solvent.
- \* A contaminated brake disc or brake pad reduces braking performance. Discard contaminated pads and clean the disc with high quality brake cleaner or neutral detergent.

**CAUTION**

Handle brake fluid with care: the fluid reacts chemically with paint, plastics, rubber materials etc. and will damage them severely.

**BRAKE PAD REPLACEMENT**

- Remove the plug ①.

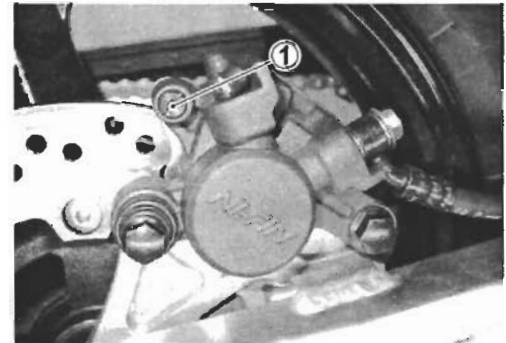

- Loosen the pad mounting pin ②.
- Remove the caliper bracket bolt ③.

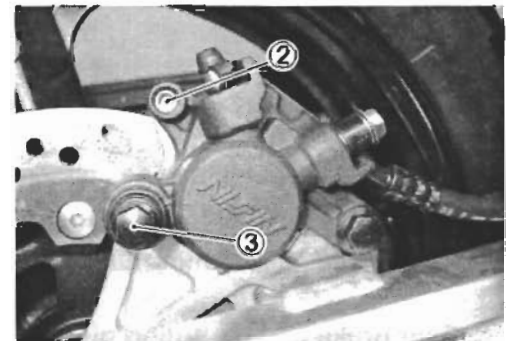
**CAUTION**

- \* Do not operate the brake pedal while dismantling the pads.
- \* Replace the brake pads as a set, otherwise braking performance will be adversely affected.

- Remove the pad mounting pin and brake pads with the rear caliper pivoted up.
- Clean up the caliper especially around the caliper pistons.

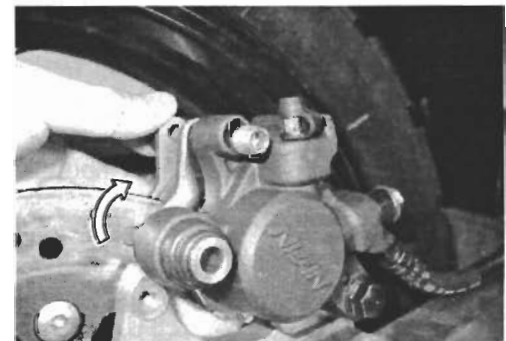

- Assemble the insulator ④ and shim ⑤ to the new brake pad ⑥.

**CAUTION**

Replace the brake pads as a set, otherwise braking performance will be adversely affected.

- Install the new brake pads.

**NOTE:**

Make sure that the detent of the pad is seated onto the retainer on the caliper bracket.

- Tighten the caliper mounting bolt ⑦ and pad mounting pin ⑧ to the specified torque.

**🔧 Rear brake caliper mounting bolt:**

22 N·m (2.2 kgf·m, 16.0 lb-ft)

**Rear brake pad mounting pin:**

17 N·m (1.7 kgf·m, 12.5 lb-ft)

- Install the plug ⑨ to the specified torque.

**🔧 Pad pin plug: 2.5 N·m (0.25 kgf·m, 1.8 lb-ft)****NOTE:**

After replacing the brake pads, pump the brake pedal several times in order to operate the brake correctly and then check the brake fluid level.

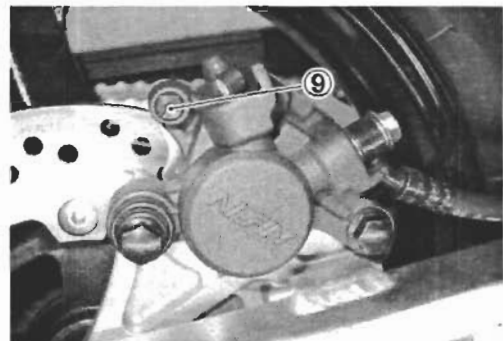
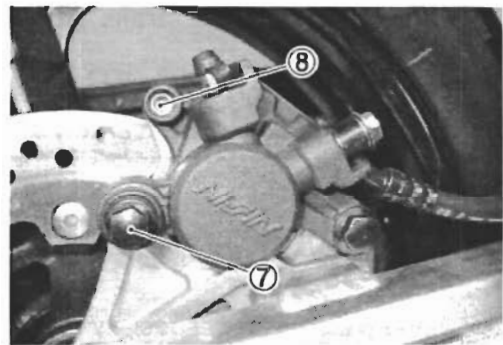
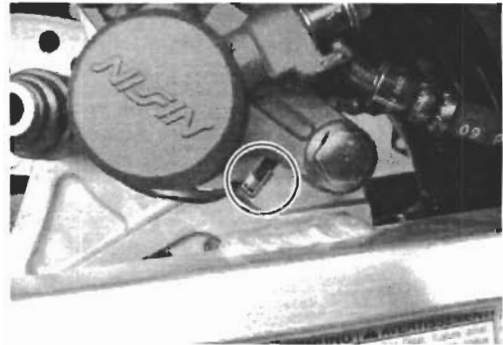
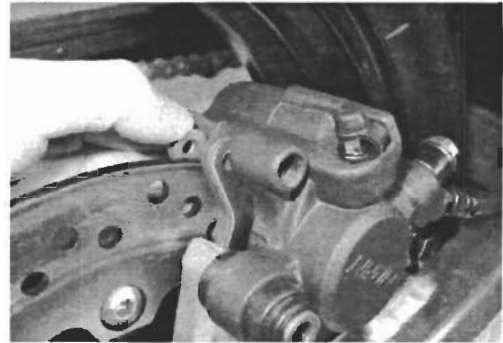
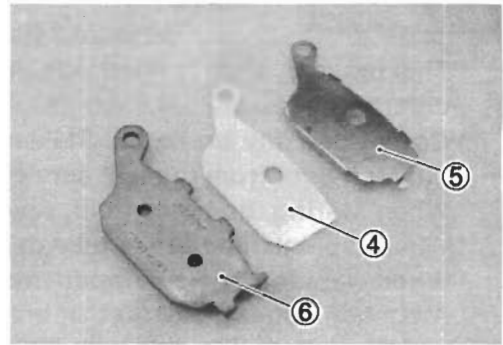

## BRAKE FLUID REPLACEMENT

- Remove the right frame cover. (☞ 7-5)
- Remove the brake fluid reservoir cap.
- Replace the brake fluid in the same manner as the front brake. (☞ 7-60)

**BF** Specification and Classification: DOT 4

### CAUTION

Bleed air from the brake system. (☞ 2-25)

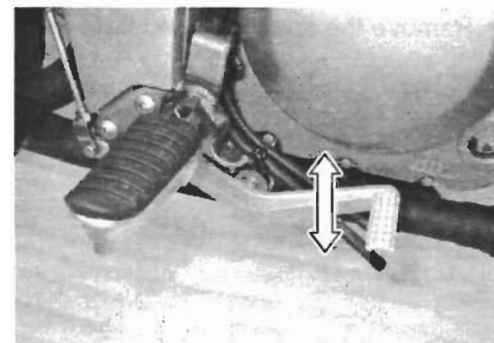
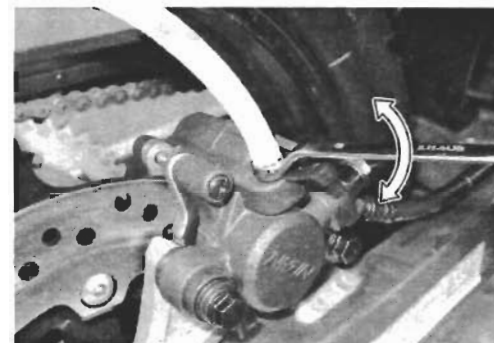
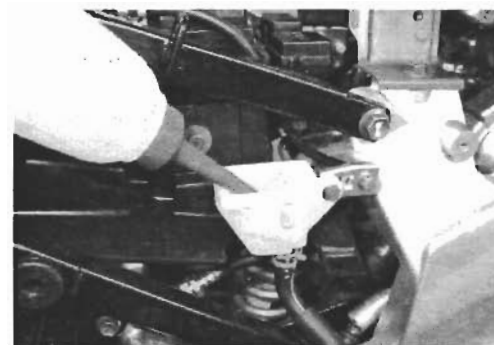

## CALIPER REMOVAL AND DISASSEMBLY

- Drain the brake fluid. (☞ 7-71)
- Remove the brake pads. (☞ 7-69)
- Place a rag underneath the union bolt to catch any spilt brake fluid.
- Disconnect the brake hose by removing the brake hose union bolt ①.

### CAUTION

Do not reuse the brake fluid left over from previous servicing and stored for long periods.

### ⚠ WARNING

Brake fluid, if it leaks, will interfere with safe running and discolor painted surfaces. Check the brake hose and hose joints for cracks and fluid leakage.

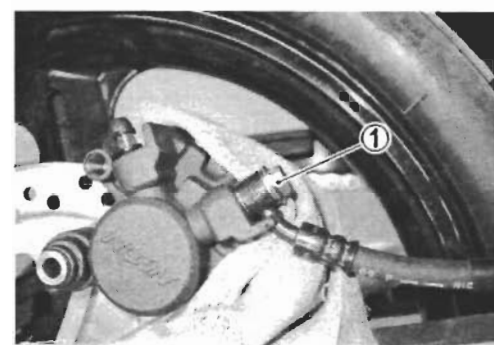

- Pivot the caliper up and remove the caliper from the caliper bracket ②.

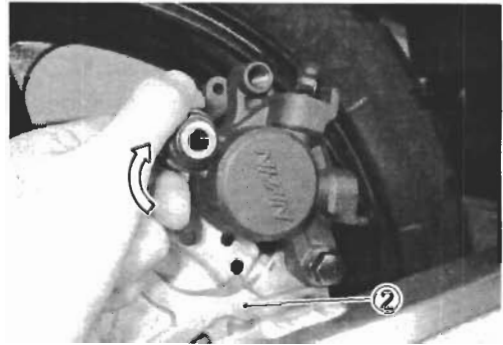

- Remove the pad spring ③.

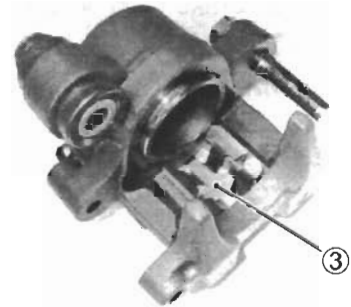

- Remove the spacer ④ and boot ⑤ from the caliper.

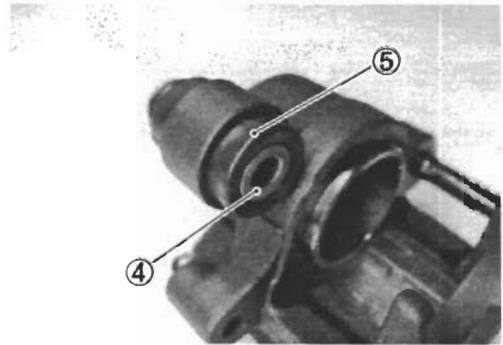

- Remove the brake caliper sliding pin ⑥.

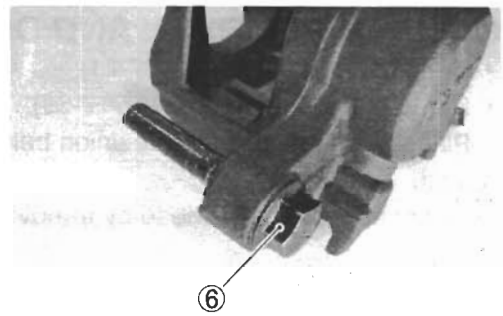

- Place a rag over the piston to prevent it from popping out and then force out the piston using compressed air.

**CAUTION**

**Do not use high pressure air to prevent piston damage.**



- Remove the dust seal ⑦ and piston seal ⑧.

**CAUTION**

Do not reuse the dust seal and piston seal to prevent fluid leakage.

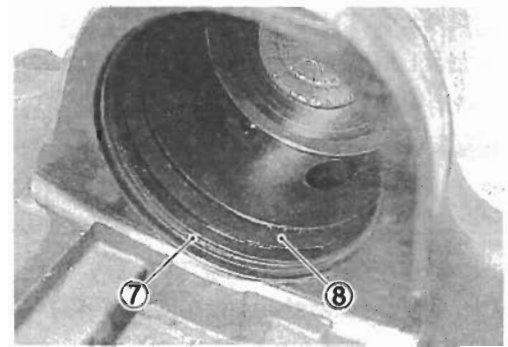
**CALIPER INSPECTION****BRAKE CALIPER**

Inspect the brake caliper cylinder wall for nicks, scratches and other damage. If any damage is found, replace the caliper with a new one.

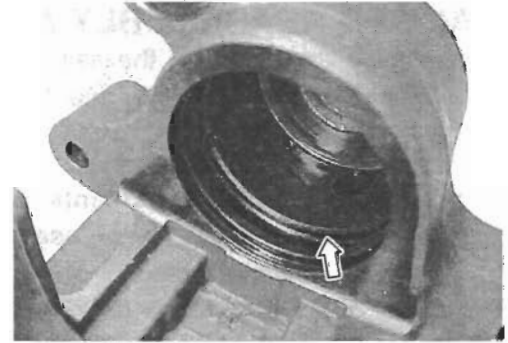
**BRAKE CALIPER PISTON**

Inspect the brake caliper piston surface for any scratches and other damage. If any damage is found, replace the caliper piston with a new one.

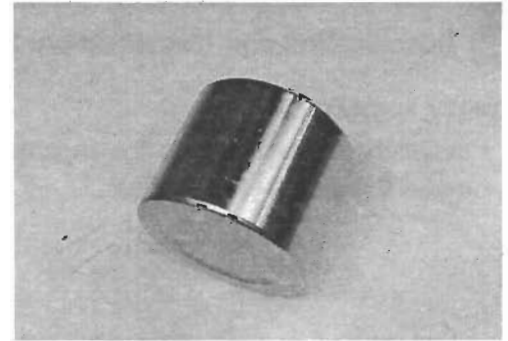
**BRAKE CALIPER SLIDING PIN**

Inspect the brake caliper sliding pin for wear and other damage. If any damage is found, replace the brake caliper sliding pin with a new one.



Inspect the boot and spacer for damage and wear. If any damage is found, replace boot and spacer with the new ones.

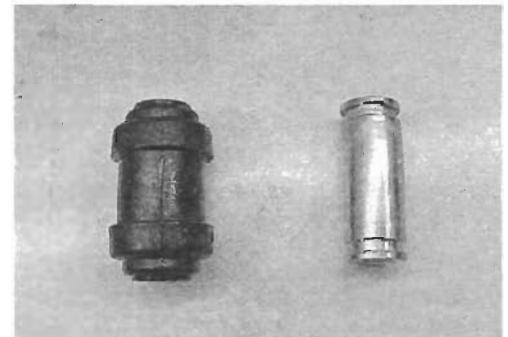



## BRAKE DISC INSPECTION

Inspect the rear brake disc in the same manner as the front brake disc. (☞ 7-65)

### DATA Service Limit

Rear disc thickness: 5 mm (0.20 in)

Rear disc runout: 0.30 mm (0.012 in)

\* Brake disc removal (☞ 7-37)

\* Brake disc installation (☞ 7-42)

## CALIPER REASSEMBLY AND REMOUNTING

Reassemble and remount the caliper in the reverse order of removal and disassembly. Pay attention to the following points:

### CAUTION

- \* Wash the caliper components with fresh brake fluid before reassembly. Never use cleaning solvent or gasoline to wash them.
- \* Apply brake fluid to the caliper bore and piston to be inserted into the bore.

**BF** Specification and Classification: DOT 4

### PISTON SEAL

- Install the piston seals as shown in the illustration.
- Install the piston to the caliper.

- ① Dust seal
- ② Piston seal
- ③ Caliper

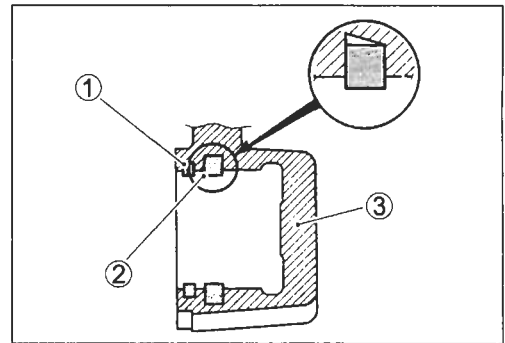
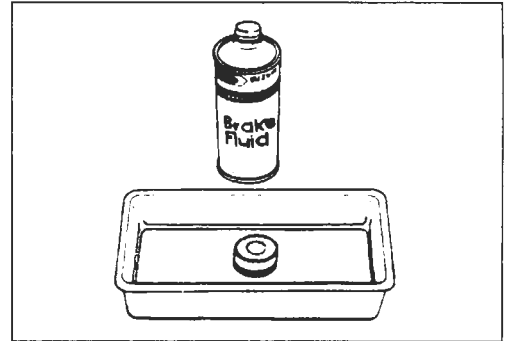

### BRAKE CALIPER SLIDING PIN

- Install the boot ①.
- Apply SUZUKI SILICONE GREASE to the inside of the boot.

**SH** 99000-25100: SUZUKI SILICONE GREASE

- Install the spacer ②.

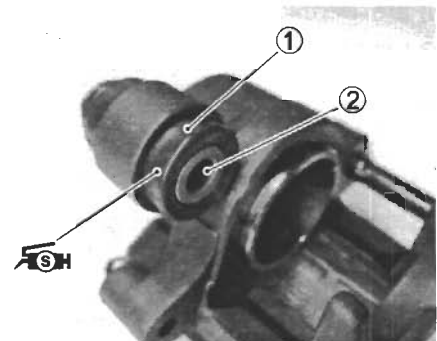

- Tighten the brake caliper sliding pin ③ to the specified torque.

**🔧 Brake caliper sliding pin: 27 N·m (2.7 kgf·m, 19.5 lb-ft)**

- Apply SUZUKI SILICONE GREASE to the brake caliper sliding pin.

**🔧 99000-25100: SUZUKI SILICONE GREASE**

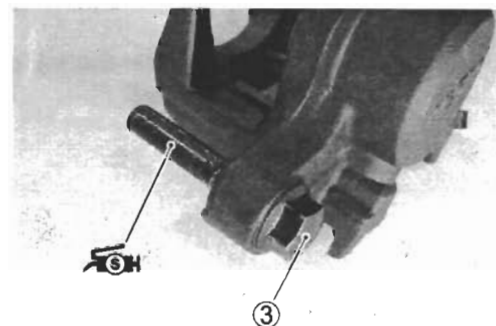

- Install the caliper to the caliper bracket ④.
- Set the boot onto the brake caliper sliding pin ⑤ securely.
- Install the brake pad. (🔧 7-69)

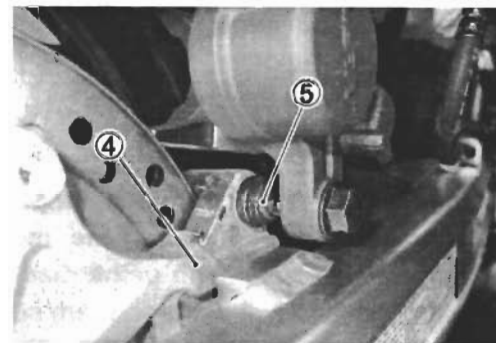

- Tighten the brake hose union bolt ⑥ with the brake hose union pipe seated in the cutout on the caliper. (Rear brake hose routing: 🔧 9-27)

**🔧 Brake hose union bolt: 23 N·m (2.3 kgf·m, 16.5 lb-ft)**

**CAUTION**

- \* The seal washers should be replaced with the new ones to prevent fluid leakage.
- \* Bleed air from the system after reassembling the caliper. (🔧 2-25)

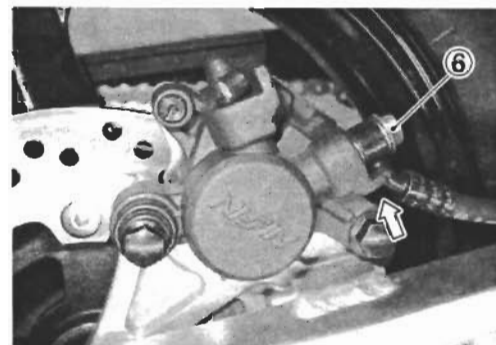

## MASTER CYLINDER REMOVAL AND DISASSEMBLY

- Drain the brake fluid. (🔧 7-71)
- Remove the brake fluid reservoir tank mounting bolt ①.

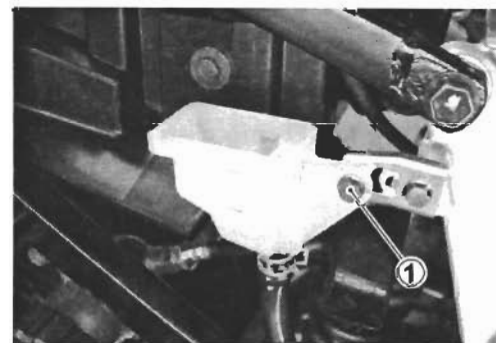

- Loosen the lock-nut ②.
- Remove the master cylinder mounting bolts ③.

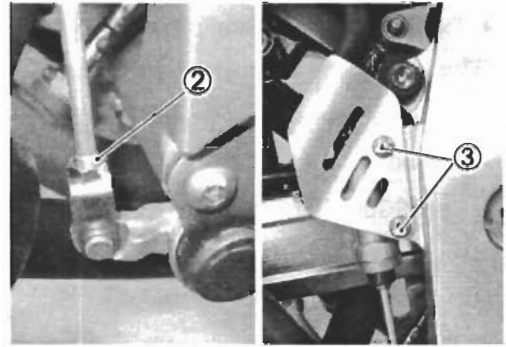

- Place a rag underneath the union bolt on the master cylinder to catch spilled drops of brake fluid. Remove the union bolt ④ and disconnect the brake hose.

**CAUTION**

Immediately and completely wipe off any brake fluid contacting any parts of the motorcycle. The fluid reacts chemically with paint, plastic and rubber materials, etc. and will damage them severely.

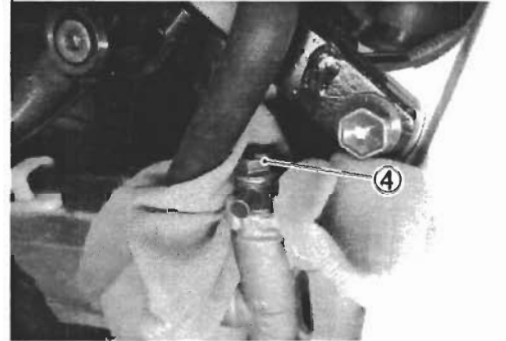

- Remove the master cylinder by turning the master cylinder rod ⑤.

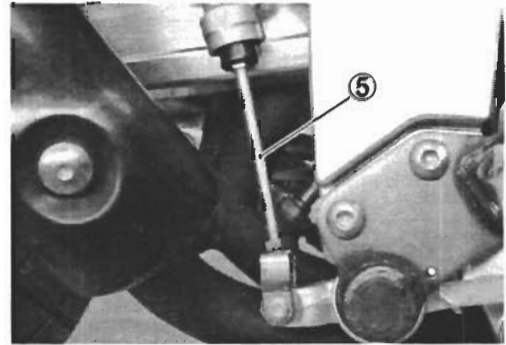

- Disconnect the reservoir hose ⑥.
- Remove the connector ⑦ by removing the snap ring ⑧.
- Remove the O-ring ⑨.

**CAUTION**

Replace the O-ring with a new one.

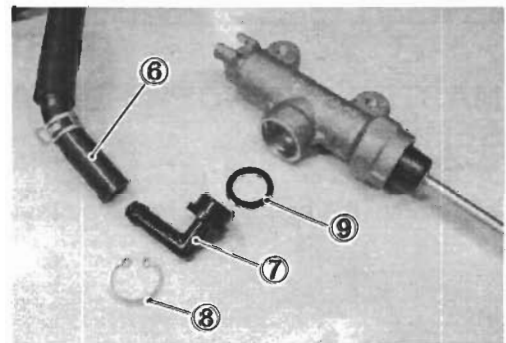

- Pull out the dust boot ⑩, then remove the snap ring ⑪.
- Remove the push rod, piston/primary cup and spring.

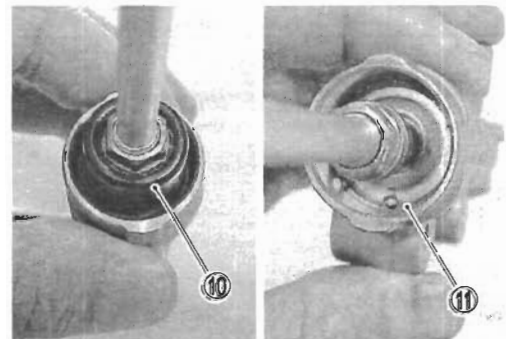

## MASTER CYLINDER INSPECTION

### CYLINDER, PISTON AND CUP SET

Inspect the cylinder bore wall for any scratches or other damage.

Inspect the cup set and each rubber part for damage.

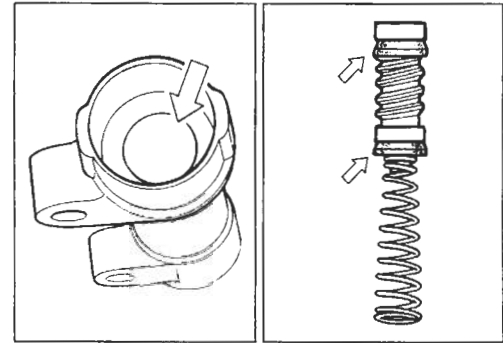

## MASTER CYLINDER REASSEMBLY AND REMOUNTING

Reassemble and remount the master cylinder in the reverse order of removal and disassembly. Pay attention to the following points:

### CAUTION

- \* Wash the master cylinder components with fresh brake fluid before reassembly. Never use cleaning solvent or gasoline to wash them.
- \* Do not wipe the components with a rag.
- \* Apply brake fluid to the cylinder bore and all the component to be inserted into the bore.

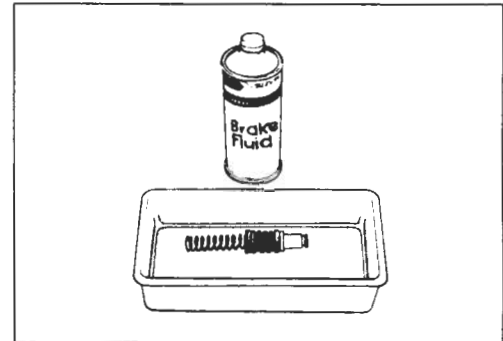

### **BF** Specification and Classification: DOT 4

- Apply brake fluid to the piston/cup set.
- Install the following parts.
  - ① Spring
  - ② Piston/primary cup
  - ③ Push rod
  - ④ Snap ring
  - ⑤ Dust boot
- Apply the SUZUKI MOLY PASTE to the push rod.

### **MH** 99000-25140: SUZUKI MOLY PASTE

- Install the O-ring ⑥, connector ⑦ and snap ring ⑧ to the master cylinder.

### CAUTION

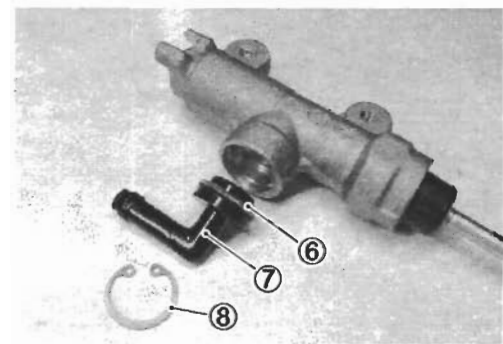
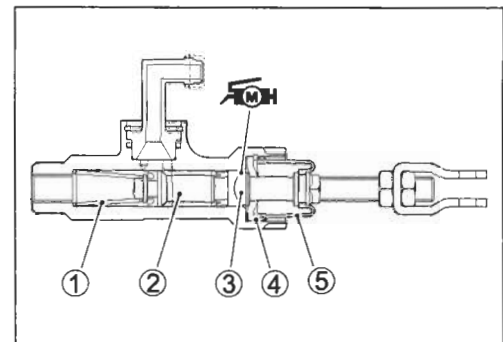

Replace the removed O-ring with a new one.

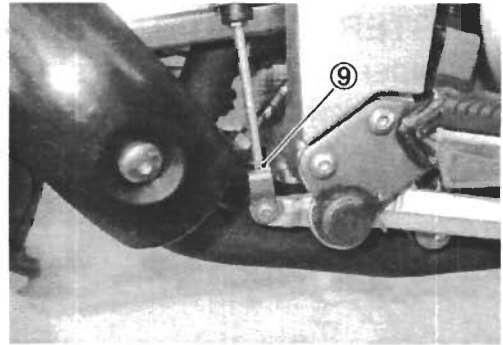

- Install the master cylinder.
- Tighten the lock-nut ⑨.

**U** Rear brake master cylinder rod lock-nut:  
18 N·m (1.8 kgf-m, 13.0 lb-ft)



- Install the reservoir tank. (Rear brake hose routing:  9-27)
- Temporarily install the master cylinder to the frame.
- Connect the brake hose to the master cylinder. (Rear brake hose routing:  9-27)
- Tighten the brake hose union bolt ⑩ to the specified torque.

**U** Brake hose union bolt: 23 N·m (2.3 kgf-m, 16.5 lb-ft)

#### CAUTION

- \* The seal washers should be replaced with the new ones to prevent fluid leakage.
- \* Bleed air from the system after reassembling the master cylinder. ( 2-25)



- Adjust the brake pedal height. ( 2-24)
- Install the master cylinder.
- Tighten the master cylinder mounting bolts ⑪ to the specified torque.

**U** Rear master cylinder mounting bolt:  
10 N·m (1.0 kgf-m, 7.0 lb-ft)

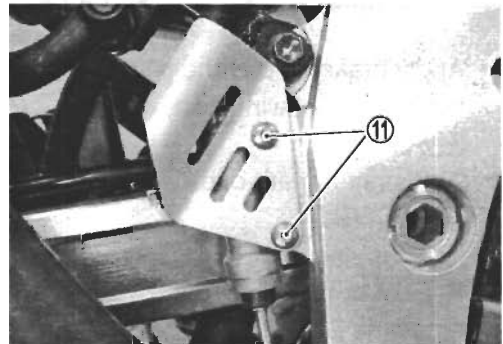

## TIRE AND WHEEL

### TIRE REMOVAL

The most critical factor of a tubeless tire is the seal between the wheel rim and the tire bead. For this reason, it is recommended to use a tire changer that can satisfy this sealing requirement and can make the operation efficient as well as functional.

For operating procedures, refer to the instructions supplied by the tire changer manufacturer.

#### NOTE:

When removing the tire in the case of repair or inspection, mark the tire with a chalk to indicate the tire position relative to the valve position.

Even though the tire is refitted to the original position after repairing puncture, the tire may have to be balanced again since such a repair can cause imbalance.

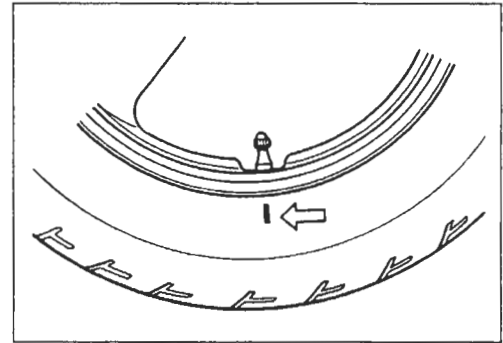

### INSPECTION

#### WHEEL

Wipe the wheel clean and check for the following:

- \* Distortion and crack
- \* Any flaws and scratches at the bead seating area
- \* Wheel rim runout (☞ 7-11)

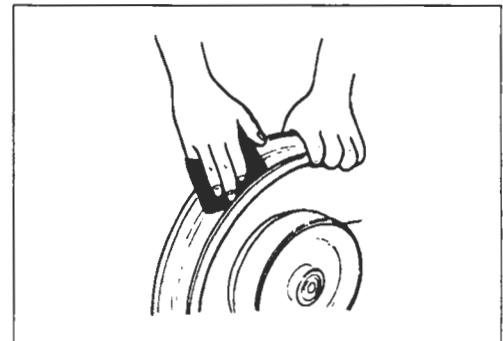

#### TIRE

Tire must be checked for the following points:

- \* Nick and rupture on side wall
- \* Tire tread depth (☞ 2-26)
- \* Tread separation
- \* Abnormal, uneven wear on tread
- \* Surface damage on bead
- \* Localized tread wear due to skidding (Flat spot)
- \* Abnormal condition of inner liner

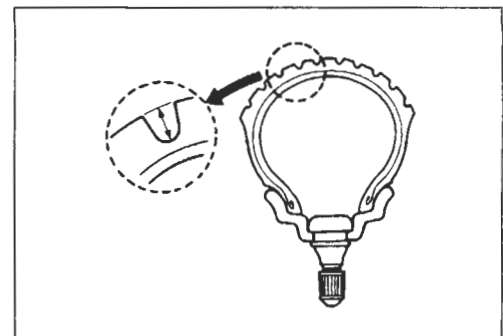
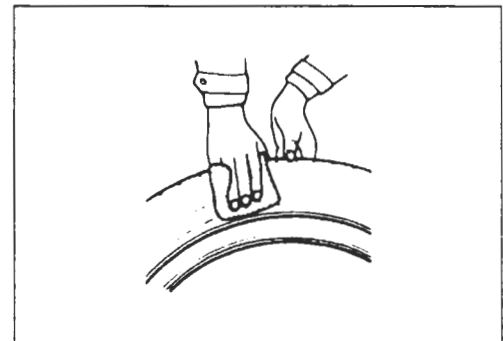

**VALVE**

- Inspect the valve after the tire is removed from the rim. Replace the valve with a new one if the seal rubber is peeling or has damage.
- Inspect the valve core. If the seal ① has abnormal deformation, replace the valve with a new one.

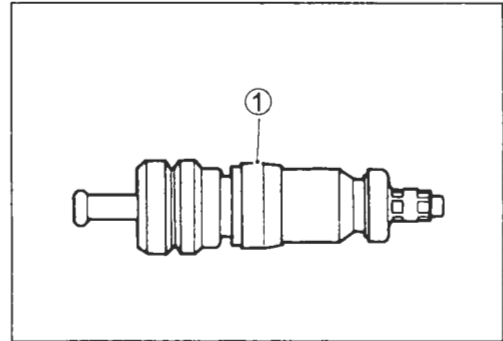
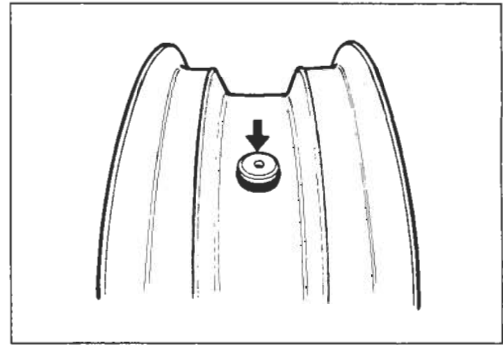
**VALVE INSTALLATION**

- Any dust or rust around the valve hole ① must be cleaned off. Then install the valve in the rim.

**NOTE:**

*To properly install the valve into the valve hole, apply a special tire lubricant or neutral soapy liquid to the valve.*

**CAUTION**

**Be careful not to damage the lip of valve.**

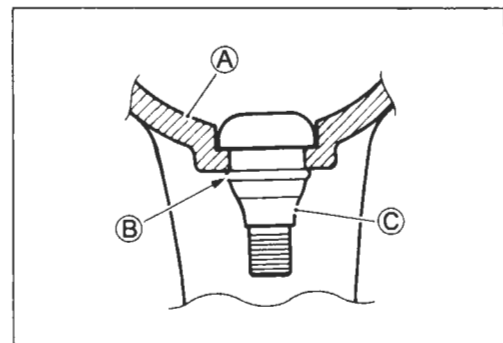
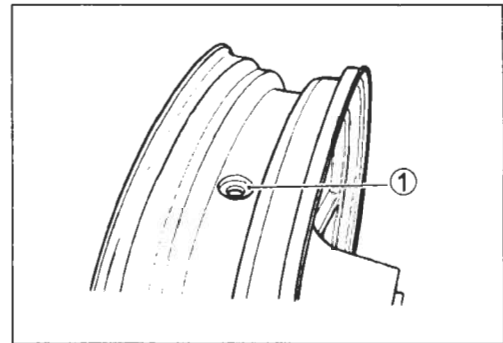

- Ⓐ Wheel
- Ⓑ Valve lip
- Ⓒ Valve

## TIRE INSTALLATION

- Apply tire lubricant to the tire bead.
- When installing the tire onto the wheel, observe the following points.

### CAUTION

- \* Do not reuse the valve which has been once removed.
- \* Do not use oil, grease or gasoline on the tire bead in place of tire lubricant.

- When installing the tire, the arrow ① on the side wall should point to the direction of wheel rotation.
- Align the chalk mark put on the tire at the time of removal with the valve position.

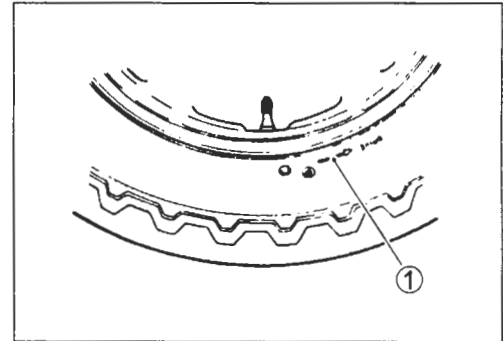
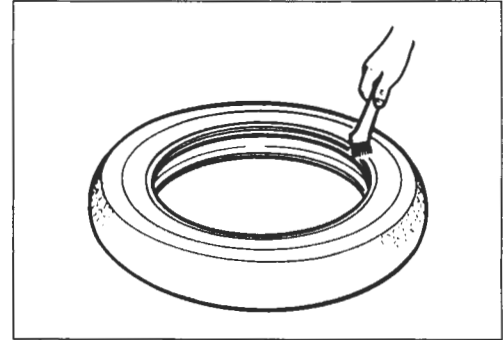

- For installation procedure of tire onto the wheel, follow the instructions given by the tire changer manufacturer.
- Bounce the tire several times while rotating. This makes the tire bead expand outward to contact the wheel, thereby facilitating air inflation.
- Inflate the tire.

### ⚠ WARNING

- \* Do not inflate the tire to more than 400 kPa (4.0kgf/cm<sup>2</sup>). If inflated beyond this limit, the tire can burst and possibly cause injury. Do not stand directly over the tire while inflating.
- \* In the case of preset pressure air inflator, pay special care for the set pressure adjustment.

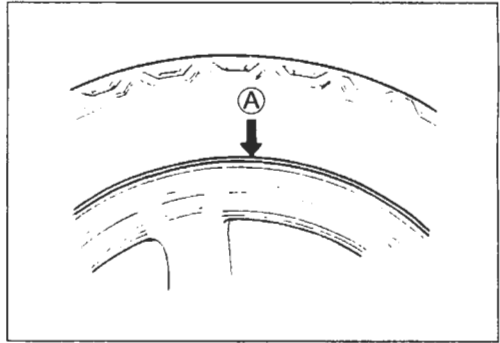

- In this condition, check the “rim line” (A) cast on the tire side walls. The line must be equidistant from the wheel rim all around. If the distance between the rim line (A) and wheel rim varies, this indicates that the bead is not properly seated. If this is the case, deflate the tire completely and unseat the bead for both sides. Coat the bead with lubricant and fit the tire again.
- When the bead has been fitted properly, adjust the pressure to specification.
- As necessary, adjust the tire balance.

**CAUTION**

Do not run with a repaired tire at a high speed.

**DATA** Tire pressure

Solo riding: Front: 225 kPa (2.25 kgf/cm<sup>2</sup>, 33 psi)

Rear : 250 kPa (2.50 kgf/cm<sup>2</sup>, 36 psi)

Dual riding: Front: 225 kPa (2.25 kgf/cm<sup>2</sup>, 33 psi)

Rear : 280 kPa (2.80 kgf/cm<sup>2</sup>, 41 psi)

## DRIVE CHAIN

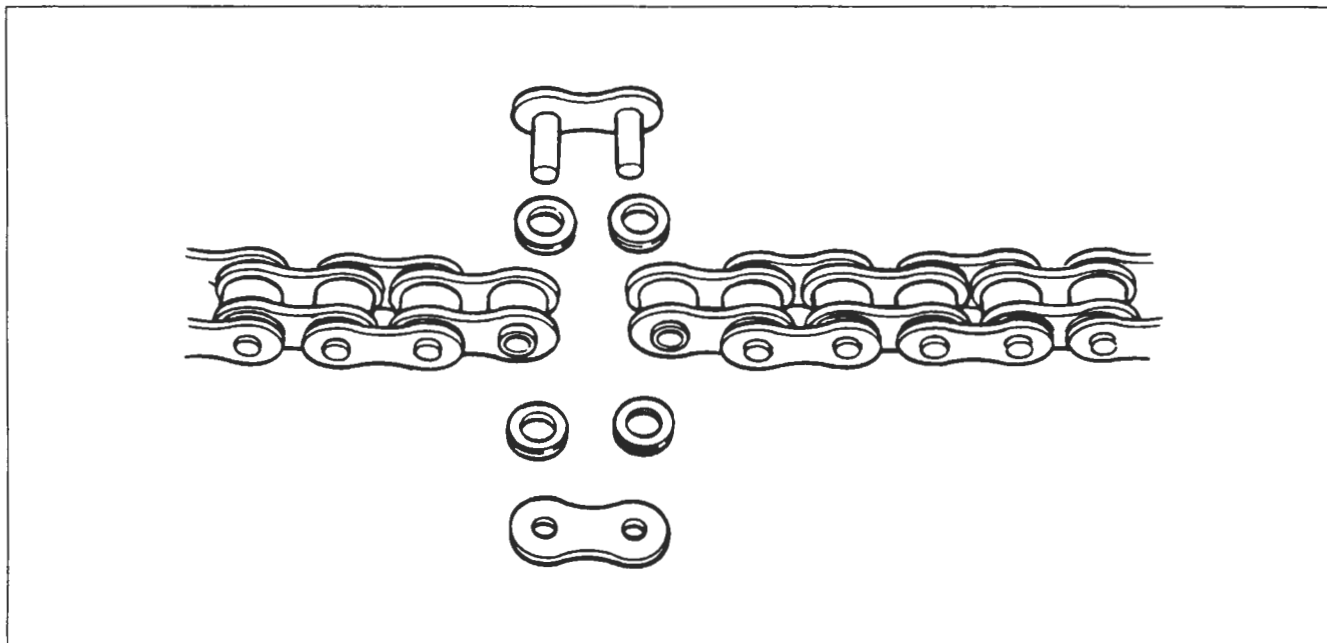

Use the special tool in the following procedures, to cut and rejoin the drive chain.

**TOOL 09922-22711: Drive chain cutting and joining tool set**

### NOTE:

When using the special tool, apply a small quantity of grease to the threaded parts of the special tool.

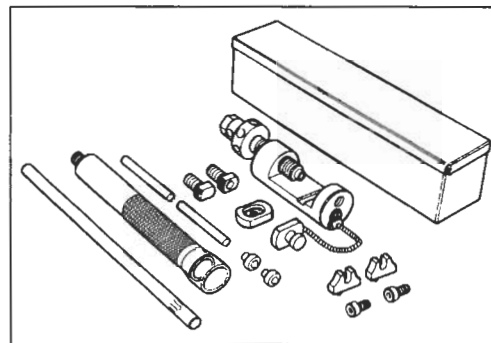

## DRIVE CHAIN CUTTING

- Set up the special tool as shown in the illustration.

- ① Tool body
- ② Grip handle
- ③ Pressure bolt "A"
- ④ Pressure bolt "B"
- ⑤ Bar
- ⑥ Adjuster bolt (with through hole)
- ⑦ Pin remover
- ⑧ Chain holder (engraved mark 500)  
with reamer bolt M5 × 10

### NOTE:

The tip of pin remover ⑦ should be positioned inside ⑧ approximately 5 mm (0.2 in) from the end face of pressure bolt "A" ③ as shown in the illustration.

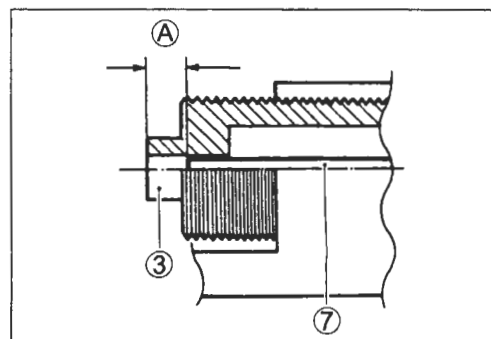
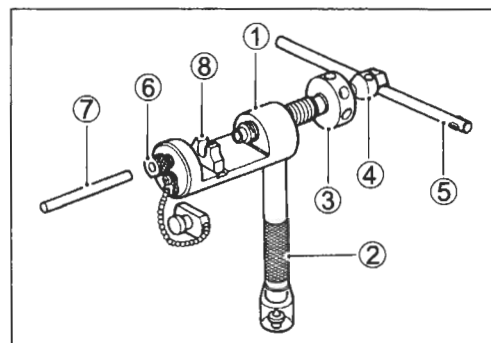

- Place the drive chain link being disjoined on the holder part ⑧ of the tool.
- Turn in both the adjuster bolt ⑥ and pressure bolt "A" ③ so that each of their end hole fits over the chain joint pin properly.
- Tighten the pressure bolt "A" ③ with the bar.

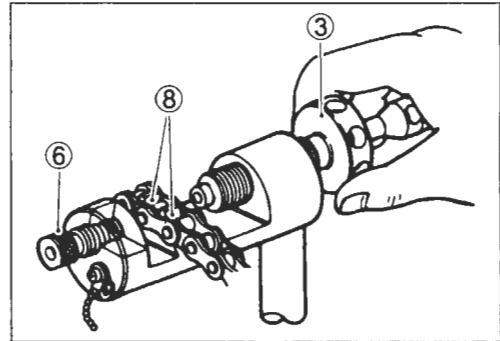

- Turn in the pressure bolt "B" ④ with the bar ⑤ and force out the drive chain joint pin ⑨.

**CAUTION**

Continue turning in the pressure bolt "B" ④ until the joint pin has been completely pushed out of the chain.

**NOTE:**

After the joint pin ⑨ is removed, loosen the pressure bolt "B" ④ and then pressure bolt "A" ③.

- Remove the joint pin ⑨ of the other side of joint plate.

**CAUTION**

Never reuse joint pins, O-rings and plates. After joint pins, O-rings and plates have been removed from the drive chain, the removed joint pins, O-rings and plates should be discarded and new joint plate, O-rings and plate must be installed.

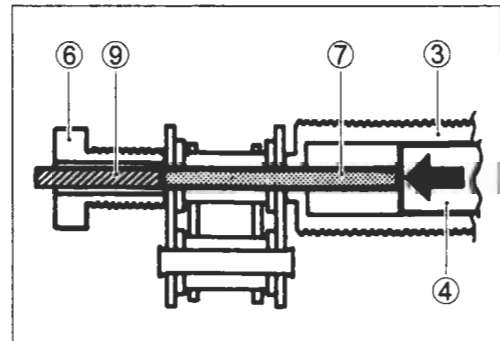
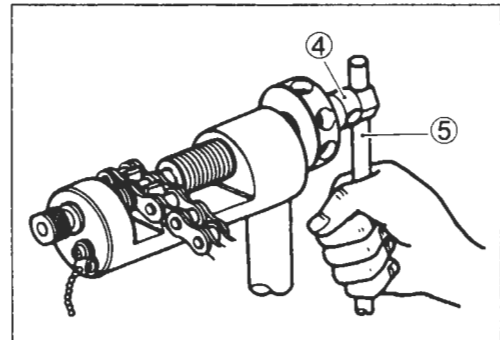

**DRIVE CHAIN CONNECTING**

**JOINT PLATE INSTALLATION**

- Set up the special tool as shown in the illustration.
    - ① Tool body
    - ② Grip handle
    - ③ Joint plate holder (engraved mark "F520")
    - ④ Wedge holder & wedge pin
    - ⑤ Adjuster bolt (without hole)
    - ⑥ Pressure bolt "A"
    - ⑦ Bar
  - Connect both ends of the drive chain with the joint pin ⑧ inserted from the wheel side (A) as installed on the motorcycle.
    - ⑨ O-ring ... 4 pcs
    - ⑩ Joint plate
- Joint set part number  
DID: 27620-32C10

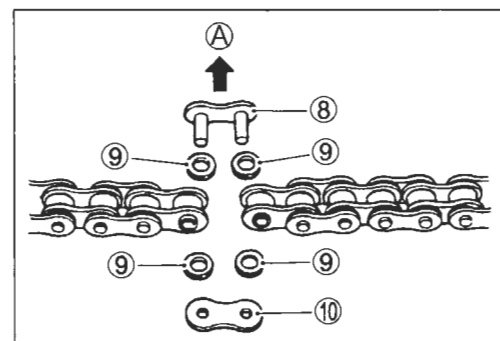
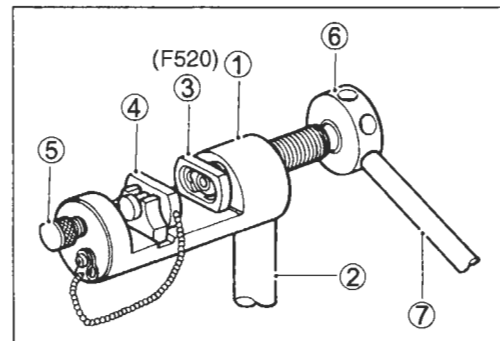

**WARNING**

Do not use joint clip type of drive chain. The joint clip may have a chance to drop which may cause severe damage to motorcycle and severe injury.

- Apply grease on the recessed portion of the joint plate holder ③ and set the joint plate ⑩.

**NOTE:**

When positioning the joint plate ⑩ on the tool, its stamp mark must face the joint plate holder ③ side.

- Set the drive chain on the tool as illustrated and turn in the adjuster bolt ⑤ to secure the wedge holder & wedge pin ④.
- Turn in the pressure bolt "A" ⑥ and align two joint pins ⑪ properly with the respective holes of the joint plate ⑩
- Turn in the pressure bolt "A" ⑥ further using the bar ⑦ to press the joint plate over the joint pins.

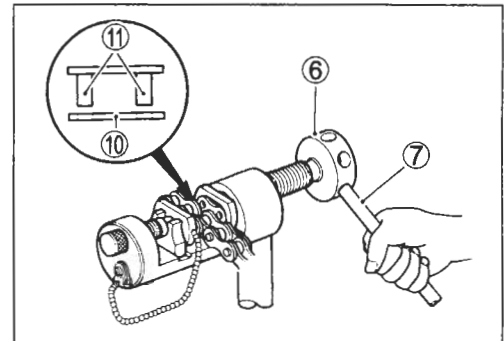
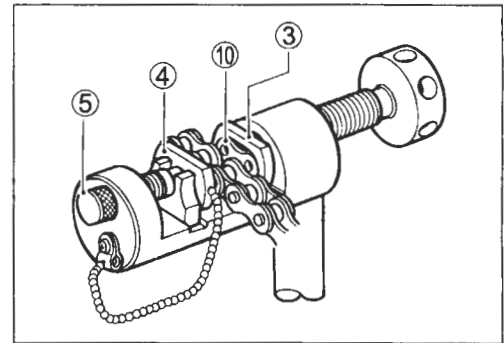

- Continue pressing the joint plate until the distance between the two joint plates come to the specification.

**DATA** Joint plate distance specification 

DID	18.70 – 18.90 mm (0.736 – 0.744 in)
-----	-------------------------------------

**CAUTION**

Should pressing of the joint plate be made excessively beyond the specified dimension, the work should be redone using the new joint parts.

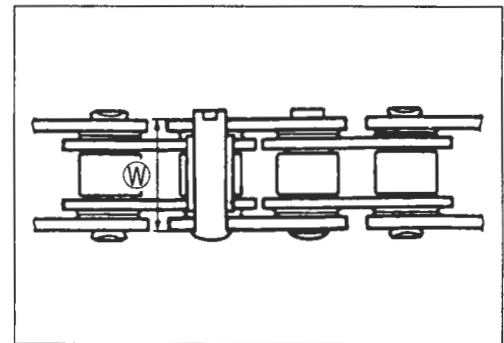
**JOINT PIN STAKING**

- Set up the special tool as shown in the illustration.
  - ① Tool body
  - ② Grip handle
  - ③ Pressure bolt "A"
  - ④ Adjuster bolt (without hole)
  - ⑤ Staking pin (stowed inside grip handle behind rubber cap)
  - ⑥ Bar

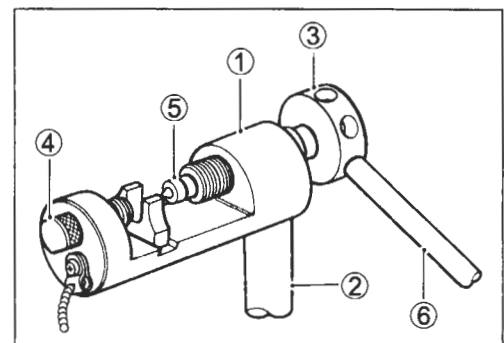
**NOTE:**

Before staking the joint pin, apply a small quantity of grease to the staking pin ⑤.

- Stake the joint pin by turning (approximately 7/8 turn) the pressure bolt "A" ③ with the bar until the pin end diameter becomes the specified dimension.

**DATA** Pin end diameter specification ④

DID	5.5 – 5.8 mm (0.217 – 0.228 in)
-----	---------------------------------

**CAUTION**

- \* After joining of the chain has been completed, check to make sure that the link is smooth and no abnormal condition is found.
- \* Should any abnormal condition be found, reassemble the chain link using the new joint parts.

- Adjust the drive chain, after connecting it. (☞ 2-21)

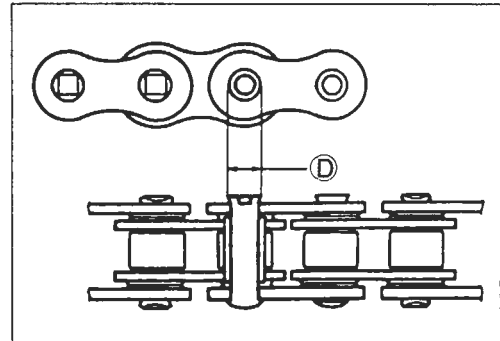
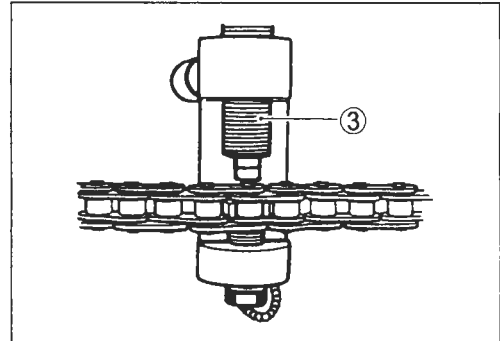

# ELECTRICAL SYSTEM

## CONTENTS

<b>CAUTIONS IN SERVICING</b> .....	8- 2
<b>CONNECTOR</b> .....	8- 2
<b>COUPLER</b> .....	8- 2
<b>CLAMP</b> .....	8- 2
<b>FUSE</b> .....	8- 2
<b>SEMI-CONDUCTOR EQUIPPED PART</b> .....	8- 3
<b>BATTERY</b> .....	8- 3
<b>CONNECTING THE BATTERY</b> .....	8- 3
<b>WIRING PROCEDURE</b> .....	8- 3
<b>USING THE MULTI CIRCUIT TESTER</b> .....	8- 4
<b>LOCATION OF ELECTRICAL COMPONENTS</b> .....	8- 5
<b>CHARGING SYSTEM</b> .....	8- 7
<b>TROUBLE SHOOTING</b> .....	8- 7
<b>INSPECTION</b> .....	8- 9
<b>STARTER SYSTEM AND SIDE-STAND/IGNITION INTERLOCK SYSTEM</b> .....	8-12
<b>TROUBLE SHOOTING</b> .....	8-12
<b>STARTER MOTOR REMOVAL AND DISASSEMBLY</b> .....	8-14
<b>STARTER MOTOR INSPECTION</b> .....	8-15
<b>STARTER MOTOR REASSEMBLY</b> .....	8-16
<b>STARTER RELAY INSPECTION</b> .....	8-19
<b>SIDE-STAND/IGNITION INTERLOCK SYSTEM PARTS INSPECTION</b> .....	8-20
<b>IGNITION SYSTEM</b> .....	8-23
<b>TROUBLESHOOTING</b> .....	8-23
<b>INSPECTION</b> .....	8-25
<b>COMBINATION METER</b> .....	8-29
<b>REMOVAL AND DISASSEMBLY</b> .....	8-29
<b>INSPECTION</b> .....	8-30
<b>INDICATORS</b> .....	8-32
<b>LAMPS</b> .....	8-36
<b>HEADLIGHT, BRAKE LIGHT/TAILLIGHT AND TURN SIGNAL LIGHT</b> .....	8-36
<b>RELAYS</b> .....	8-37
<b>TURN SIGNAL/SIDE-STAND RELAY</b> .....	8-37
<b>STARTER RELAY</b> .....	8-37
<b>FUEL PUMP RELAY</b> .....	8-37
<b>SWITCHES</b> .....	8-38
<b>INSPECTION</b> .....	8-39
<b>BATTERY</b> .....	8-40
<b>SPECIFICATIONS</b> .....	8-40
<b>INITIAL CHARGING</b> .....	8-40
<b>SERVICING</b> .....	8-42
<b>RECHARGING OPERATION</b> .....	8-42

## CAUTIONS IN SERVICING

### CONNECTOR

- When connecting a connector, be sure to push it in until a click is felt.
- Inspect the connector for corrosion, contamination and breakage in its cover.

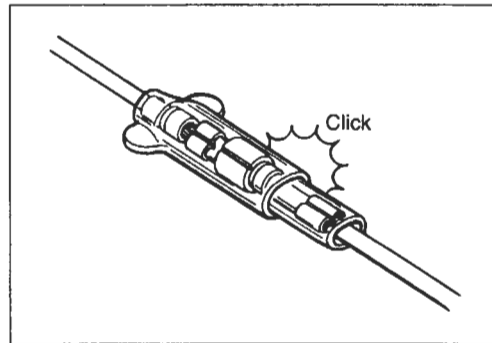

### COUPLER

- With a lock type coupler, be sure to release the lock before disconnecting it and push it in fully till the lock works when connecting it.
- When disconnecting the coupler, be sure to hold the coupler itself and do not pull the lead wires.
- Inspect each terminal on the coupler for being loose or bent.
- Inspect each terminal for corrosion and contamination.

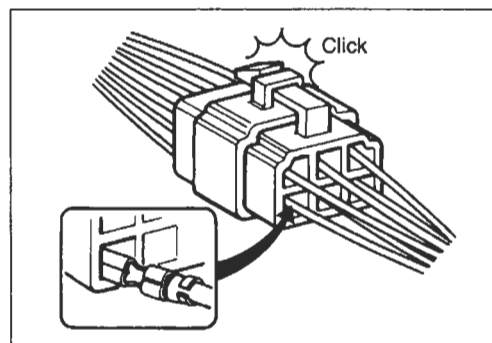

### CLAMP

- Clamp the wire harness at such positions as indicated in "WIRE HARNESS ROUTING". (9-16 to 9-18)
- Bend the clamp properly so that the wire harness is clamped securely.
- In clamping the wire harness, use care not to allow it to hang down.
- Do not use wire or any other substitute for the band type clamp.

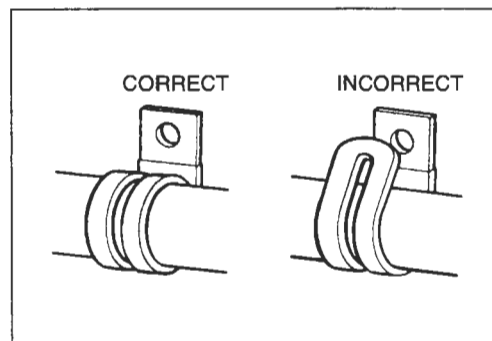

### FUSE

- When a fuse blows, always investigate the cause, correct it and then replace the fuse.
- Do not use a fuse of a different capacity.
- Do not use wire or any other substitute for the fuse.

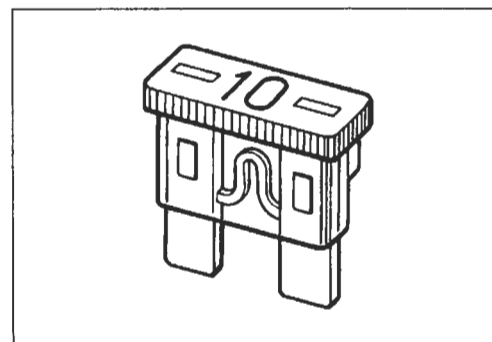

## SEMI-CONDUCTOR EQUIPPED PART

- Be careful not to drop the part with a semi-conductor built in such as a ECM.
- When inspecting this part, follow inspection instruction strictly. Neglecting proper procedure may cause damage to this part.

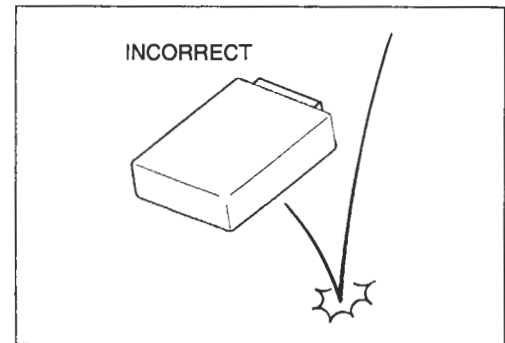

## BATTERY

- The MF battery used in this motorcycle does not require maintenance (e.g., electrolyte level inspection, distilled water replenishment).
- During normal charging, no hydrogen gas is produced. However, if the battery is overcharged, hydrogen gas may be produced. Therefore, be sure there are no fire or spark sources (e.g., short circuit) nearby when charging the battery.
- Be sure to recharge the battery in a well-ventilated and open area.
- Note that the charging system for the MF battery is different from that of a conventional battery. Do not replace the MF battery with a conventional battery.

## CONNECTING THE BATTERY

- When disconnecting terminals from the battery for disassembly or servicing, be sure to disconnect the  $\ominus$  battery lead wire, first.
- When connecting the battery lead wires, be sure to connect the  $\oplus$  battery lead wire, first.
- If the terminal is corroded, remove the battery, pour warm water over it and clean it with a wire brush.
- After connecting the battery, apply a light coat of grease to the battery terminals.
- Install the cover over the  $\oplus$  battery terminal.

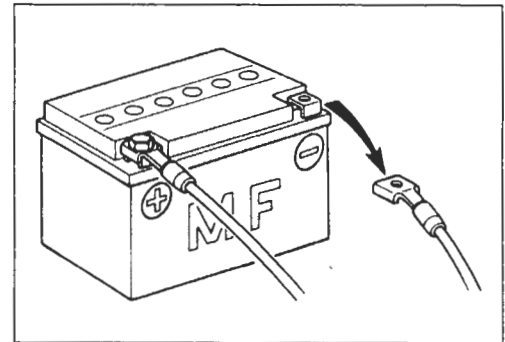

## WIRING PROCEDURE

- Properly route the wire harness according to the "WIRE ROUTING" section. (☞ 9-16 to 9-18)

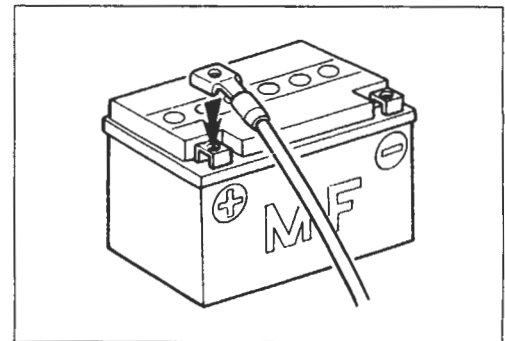



## USING THE MULTI CIRCUIT TESTER

- Properly use the multi circuit tester  $\oplus$  and  $\ominus$  probes. Improper use can cause damage to the motorcycle and tester.
- If the voltage and current values are not known, begin measuring in the highest range.
- When measuring the resistance, make sure that no voltage is applied. If voltage is applied, the tester will be damaged.
- After using the tester, be sure to turn the switch to the OFF position.

### CAUTION

Before using the multi circuit tester, read its instruction manual.

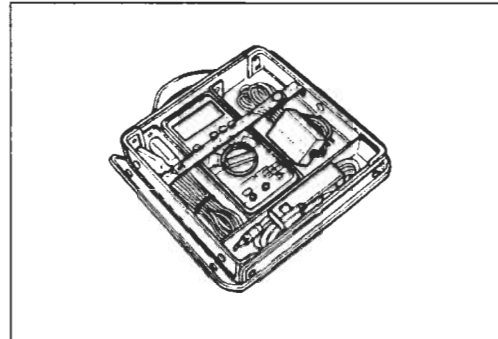

## LOCATION OF ELECTRICAL COMPONENTS

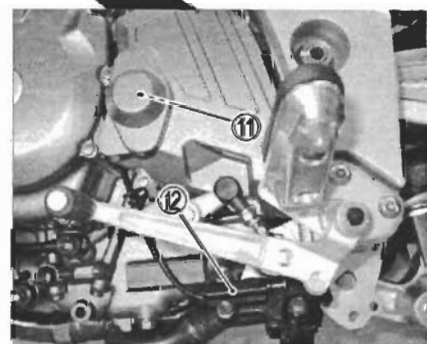
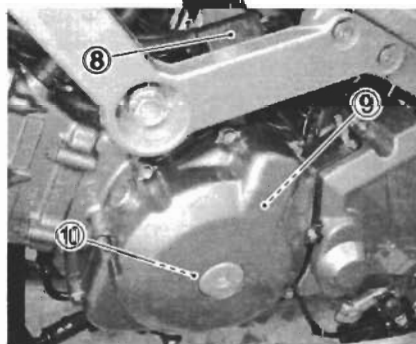
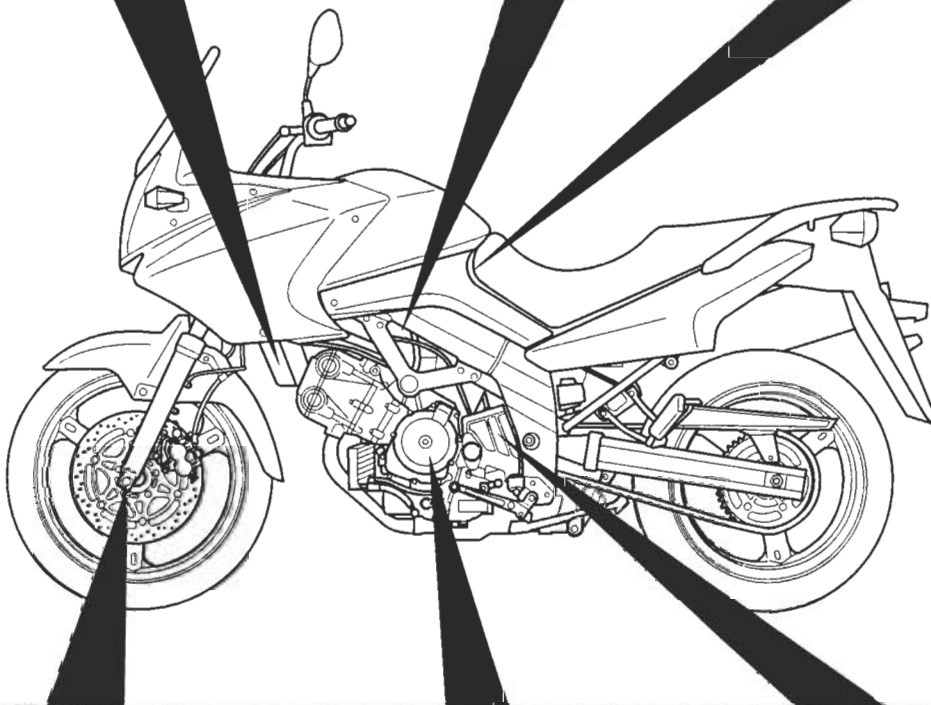
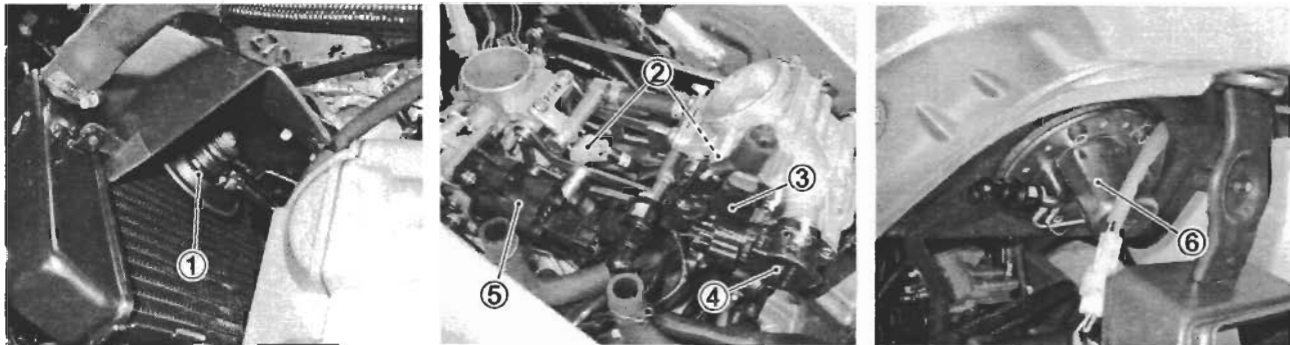

- ① Horn
- ② Fuel injector (☞ 4-42)
- ③ STP sensor (☞ 4-38)
- ④ TP sensor (☞ 4-28)
- ⑤ STV actuator (☞ 4-37)
- ⑥ Fuel pump (☞ 5-9)

- ⑦ Speed sensor (☞ 8-35)
- ⑧ Ignition coil (No.1)
- ⑨ CKP sensor (☞ 4-23)
- ⑩ Generator (☞ 8-10)
- ⑪ Gear position switch (☞ 8-20)
- ⑫ Side-stand switch (☞ 8-20)

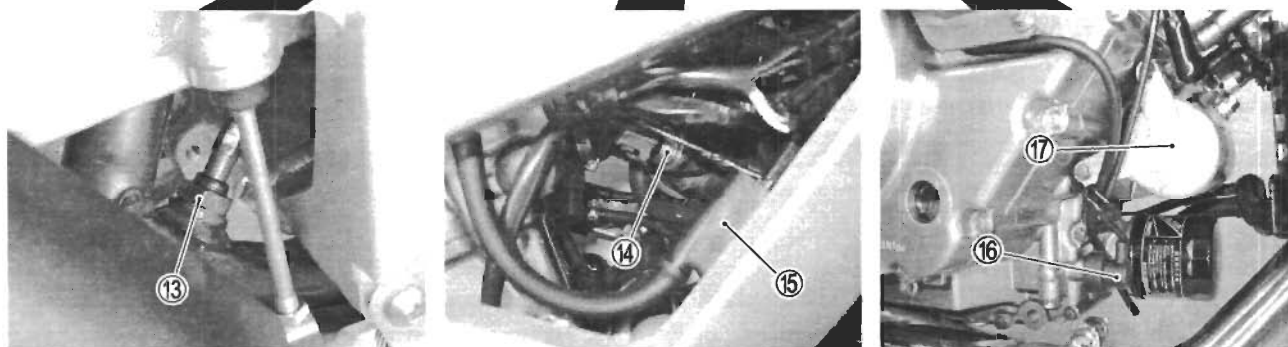
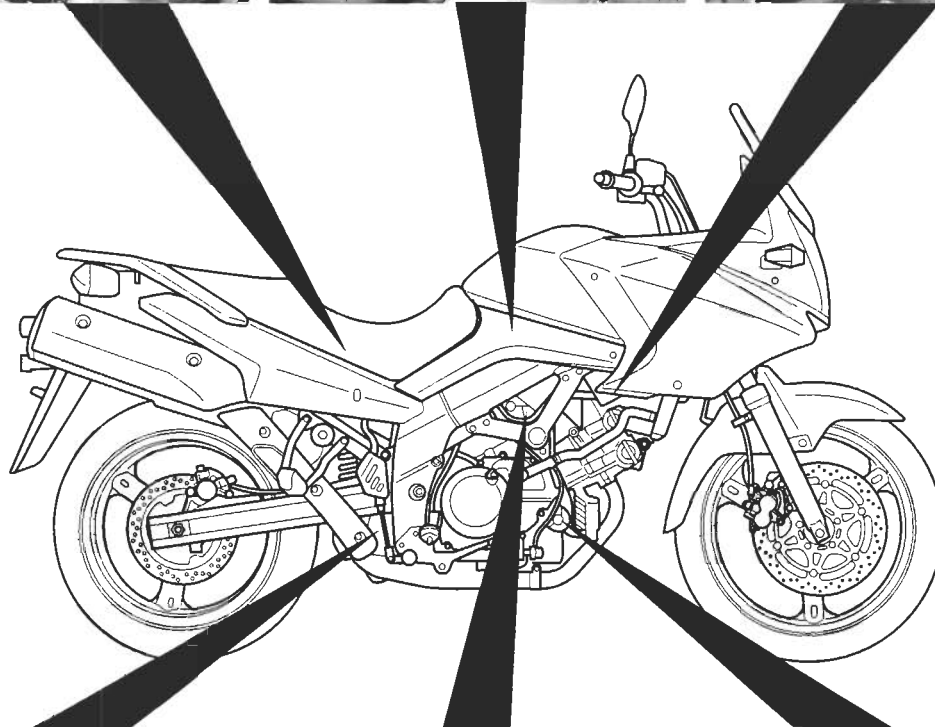
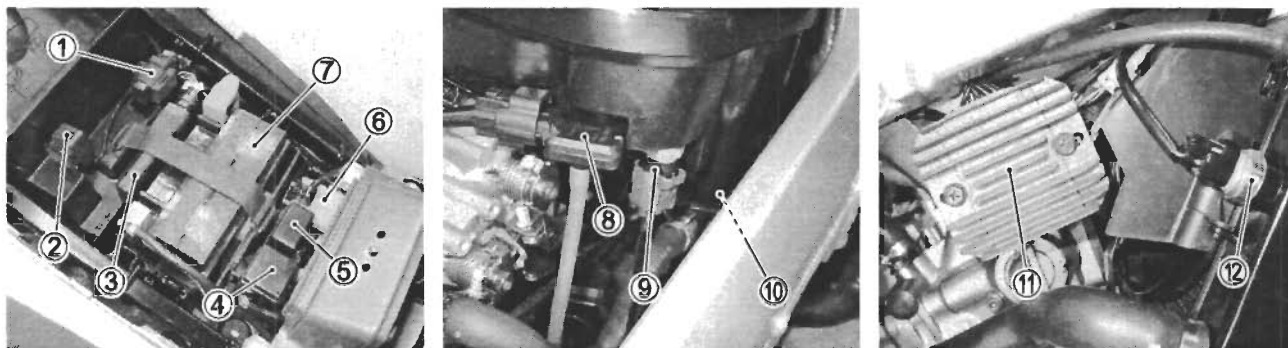

- |   |                                     |
|---|-------------------------------------|
| ① TO sensor (☞ 4-35)                    | ⑩ PAIR control valve (☞ 10-7)       |
| ② Fuel pump relay (☞ 5-10)              | ⑪ Regulator/rectifier (☞ 8-11)      |
| ③ ECM (Engine Control Module)           | ⑫ Cooling fan thermo-switch (☞ 6-9) |
| ④ Fuse box                              | ⑬ HO2 sensor (☞ 4-47)               |
| ⑤ Turn signal/side-stand relay (☞ 8-37) | ⑭ ECT sensor (☞ 4-31)               |
| ⑥ Starter relay (☞ 8-19)                | ⑮ Ignition coil (No.2)              |
| ⑦ Battery                               | ⑯ Oil pressure switch               |
| ⑧ IAP sensor (☞ 4-25)                   | ⑰ Starter motor                     |
| ⑨ IAT sensor (☞ 4-33)                   |                                     |

## CHARGING SYSTEM

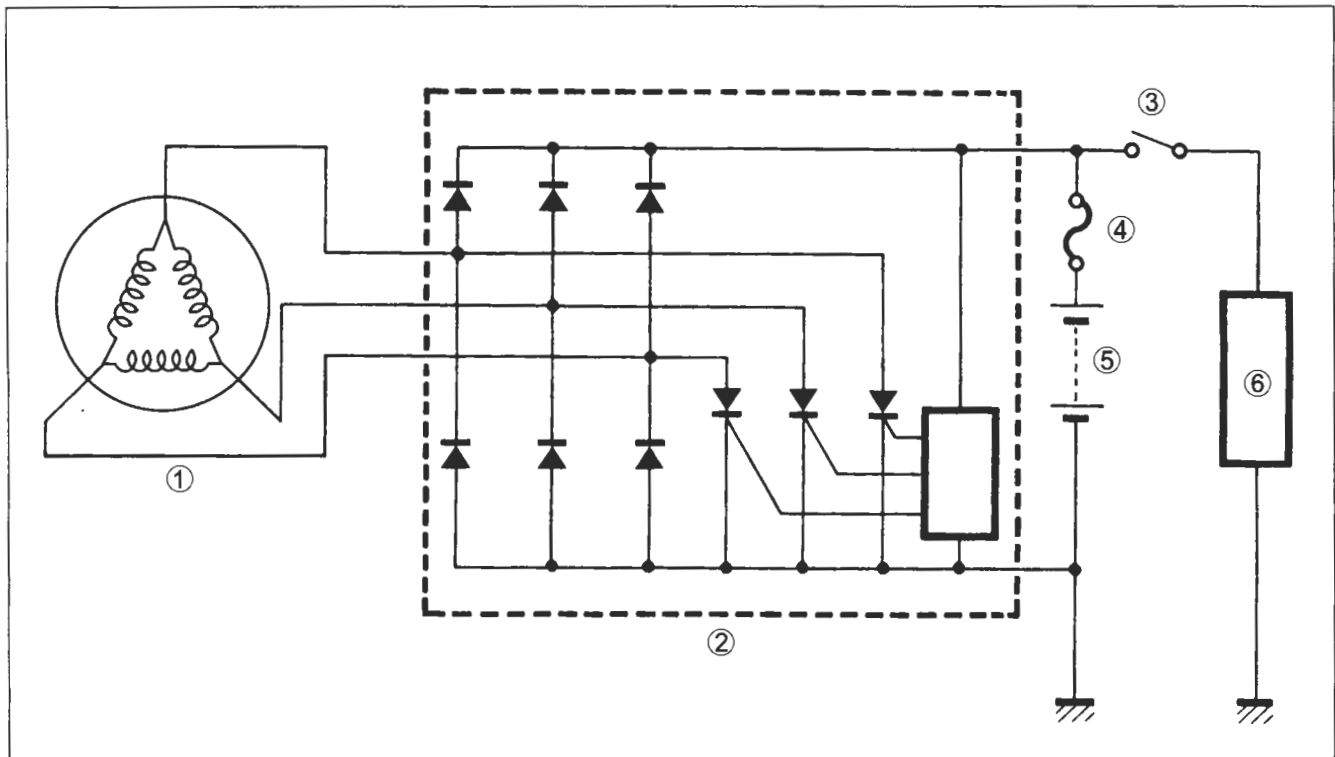

① Generator ② Regulator/rectifier ③ Ignition switch ④ Main fuse ⑤ Battery ⑥ Load

## TROUBLE SHOOTING

### Battery runs down quickly

#### Step1

- 1) Check accessories which use excessive amounts of electricity.

Are accessories being installed?

YES	Remove accessories.
NO	Go to Step2.

#### Step2

- 1) Check the battery for current leaks. (☞ 8-9)

Is the battery for current leaks OK?

YES	Go to Step3.
NO	<ul style="list-style-type: none"> <li>• Short circuit of wire harness.</li> <li>• Faulty electrical equipment.</li> </ul>

#### Step3

- 1) Measure the charging voltage between the battery terminals. (☞ 8-9)

Is the battery charging of voltage OK?

YES	<ul style="list-style-type: none"> <li>• Faulty battery.</li> <li>• Abnormal driving condition.</li> </ul>
NO	Go to Step4.

**Step4**

- 1) Measure the continuity of the generator coil. (☞ 8-10)  
 Is the resistance of generator coil OK?

YES	Go to Step5.
NO	<ul style="list-style-type: none"> <li>• Faulty generator coil.</li> <li>• Disconnected lead wires.</li> </ul>

**Step5**

- 1) Measure the generator no-load voltage. (☞ 8-10)  
 Is generator no-load performance OK?

YES	Go to Step6.
NO	Faulty generator.

**Step6**

- 1) Inspect the regulator/rectifier. (☞ 8-11)  
 Is the regulator/rectifier OK?

YES	Go to Step7.
NO	Faulty regulator/rectifier.

**Step7**

- 1) Inspect the wire harness.  
 Is the wire harness OK?

YES	Faulty battery
NO	<ul style="list-style-type: none"> <li>• Short circuit of wire harness.</li> <li>• Poor contact of coupler.</li> </ul>

**Battery overcharges**

Faulty regulator/rectifier.

Faulty battery.

Poor contact of generator lead wire coupler.

## INSPECTION

### BATTERY CURRENT LEAKAGE

- Remove the seat. (☞ 7-4)
- Turn the ignition switch to the OFF position.
- Disconnect the battery ⊖ lead wire.

Measure the current between ⊖ battery terminal and the ⊖ battery lead wire using the multi circuit tester. If the reading exceeds the specified value, leakage is evident.

**TOOL** 09900-25008: Multi circuit tester set

**DATA** Battery current (leak): 3 mA and less

**TESTER** Tester knob indication: Current (---, 20 mA)

#### CAUTION

- \* Because the current leak might be large, turn the tester to high range first to avoid tester damage.
- \* Do not turn the ignition switch to the "ON" position when measuring current.

When checking to find the excessive current leakage, remove the couplers and connectors, one by one, checking each part.

### REGULATED VOLTAGE

- Remove the seat. (☞ 7-4).
- Start the engine and keep it running at 5 000 r/min. with the dimmer switch turned HI position.

Measure the DC voltage between the ⊕ and ⊖ battery terminals using the multi circuit tester. If the voltage is not within the specified value, inspect the generator and regulator/rectifier. (☞ 8-10 and 8-11)

#### NOTE:

When making this test, be sure that the battery is in fully-charged condition.

**TOOL** 09900-25008: Multi circuit tester set

**TESTER** Tester knob indication: Voltage (---)

**DATA** Charging output (Regulated voltage):

14.0 – 15.5 V at 5 000 r/min.

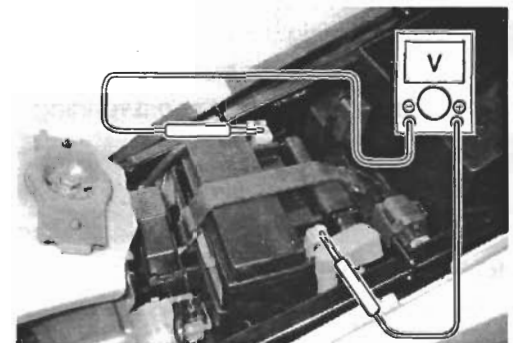
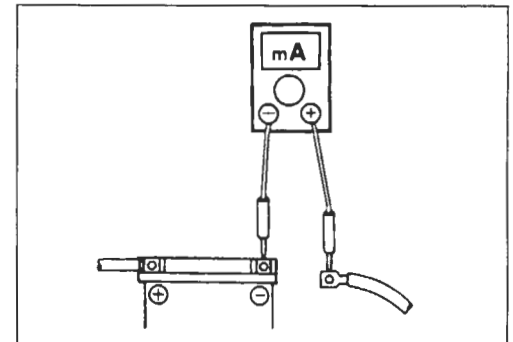
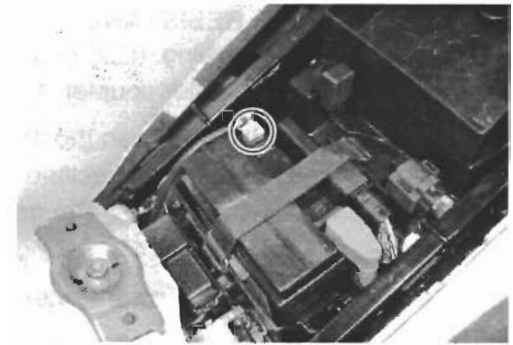

**GENERATOR COIL RESISTANCE**

- Remove the right cowling. (☞7-5)
- Disconnect the generator coupler ①.

Measure the resistance between the three lead wires.

If the resistance is out of the specified value, replace the stator with a new one. Also, check that the generator core is insulated properly.

**TOOL** 09900-25008: Multi circuit tester set

**TESTER** Tester knob indication: Resistance ( $\Omega$ )

**DATA** Generator coil resistance: 0.2 – 0.7  $\Omega$  (Black – Black)  
 $\infty$   $\Omega$  (Black – Ground)

**NOTE:**

When making above test, it is not necessary to remove the generator.

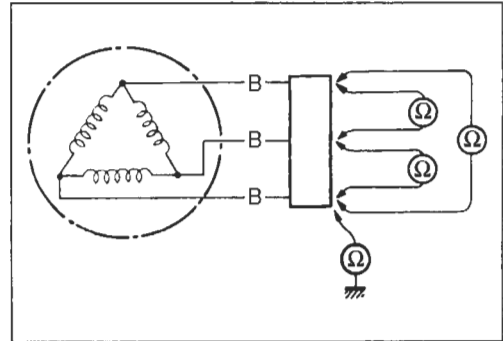
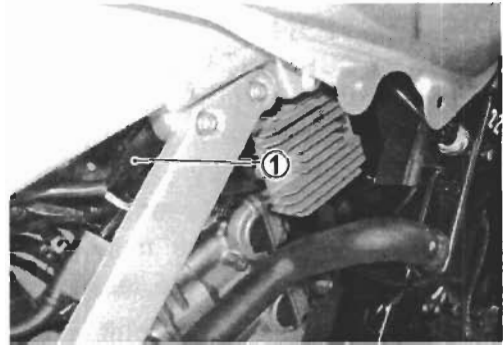
**GENERATOR NO-LOAD PERFORMANCE**

- Remove the right cowling. (☞7-5)
- Disconnect the generator coupler.
- Start the engine and keep it running at 5 000 r/min.

Using the multi circuit tester, measure the voltage between three lead wires.

If the tester reads under the specified value, replace the generator with a new one.

**TOOL** 09900-25008: Multi circuit tester set

**TESTER** Tester knob indication: Voltage (V)

**DATA** Generator no-load performance:  
 60 V and more at 5 000 r/min (When engine is cold)

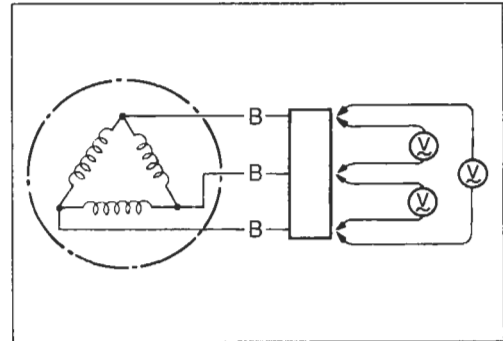

**REGULATOR/RECTIFIER**

- Remove the right cowling. (☞ 7-5)
- Disconnect the regulator/rectifier couplers ①.
- Remove the regulator/rectifier ②.

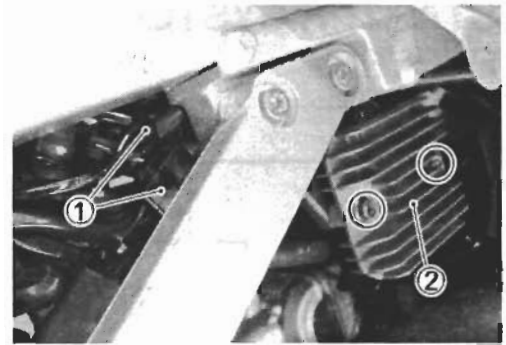

Measure the voltage between the terminals using the multi circuit tester as indicated in the table below. If the voltage is not within the specified value, replace the regulator/rectifier with a new one.

 **09900-25008: Multi circuit tester set**

 **Tester knob indication: Diode test (↔)**

Unit: V

		⊕ Tester probe				
		B/R	B1	B2	B3	B/W
Tester probe ⊖	B/R		0.4 - 0.7	0.4 - 0.7	0.4 - 0.7	0.5 - 1.2
	B1	*		*	*	0.4 - 0.7
	B2	*	*		*	0.4 - 0.7
	B3	*	*	*		0.4 - 0.7
	B/W	*	*	*	*	

\* 1.4 V and more (tester's battery voltage)

**NOTE:**

If the tester reads 1.4 V and below when the tester probes are not connected, replace its battery.

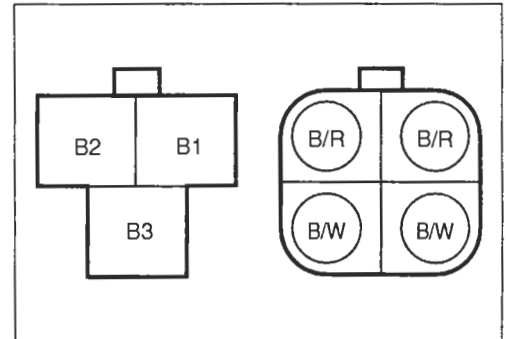



## STARTER SYSTEM AND SIDE-STAND/IGNITION INTERLOCK SYSTEM

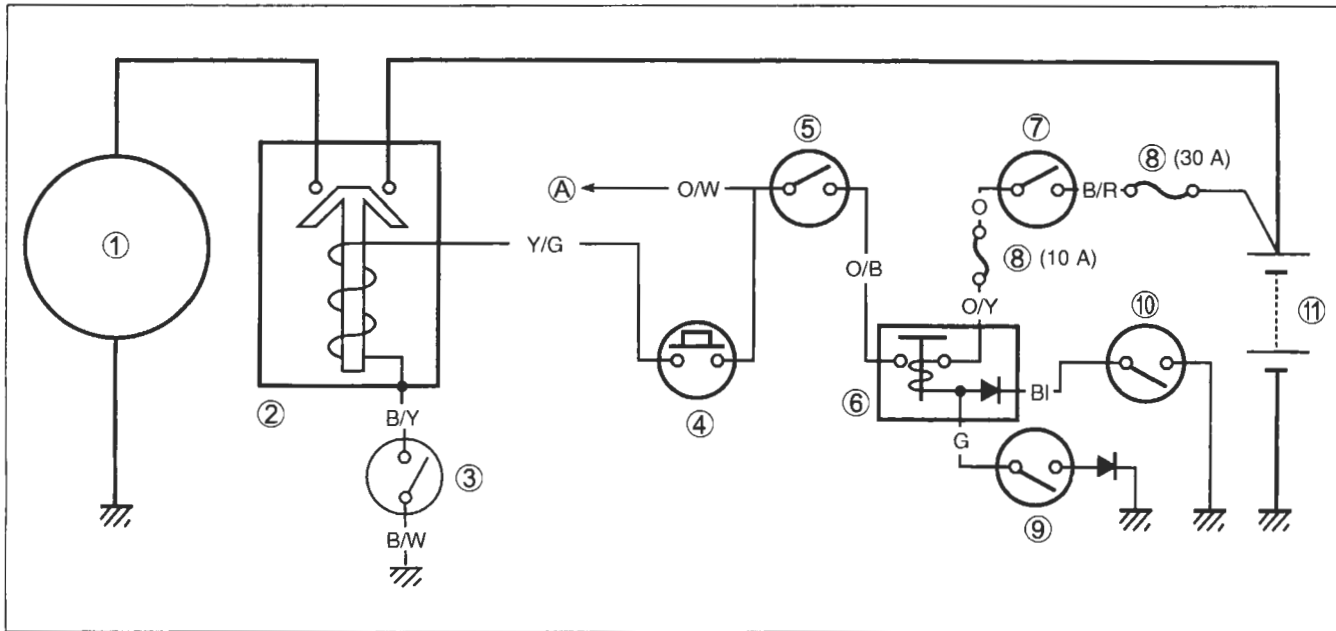

- ① Starter motor   ② Starter relay   ③ Clutch switch   ④ Starter button   ⑤ Engine stop switch  
 ⑥ Turn signal/side-stand relay   ⑦ Ignition switch   ⑧ Fuse   ⑨ Side-stand switch  
 ⑩ Gear position switch   ⑪ Battery   A To ECM and ignition coil.

### TROUBLE SHOOTING

Make sure that the fuses are not blown and the battery is fully-charged before diagnosing.

#### Starter motor will not run.

##### Step1

- 1) Grasp the clutch lever, turn on the ignition switch with the engine stop switch in the "RUN" position and side-stand switch in the "ON" position.
- 2) Listen for a click from the starter relay when the starter button is pushed.  
Is a click sound heard?

YES	Go to Step2.
NO	Go to Step3.

##### Step2

- 1) Check if the starter motor runs when its terminal is connected to the ⊕ battery terminal (Do not use a thin wire because a large amount of current flows.)  
Does the starter motor run?

YES	<ul style="list-style-type: none"> <li>• Faulty starter relay.</li> <li>• Loose or disconnected starter motor lead wire.</li> <li>• Loose or disconnected between starter relay and ⊕ battery terminal.</li> </ul>
NO	Faulty starter motor.

**Step3**

1) Measure the starter relay voltage at the starter relay connectors (between B/Y and Y/G) when the starter button is pushed.

Is a voltage OK?

YES	Go to Step4.
NO	<ul style="list-style-type: none"> <li>• Faulty gear position switch.</li> <li>• Faulty starter button.</li> <li>• Faulty engine stop switch.</li> <li>• Faulty turn signal/side-stand relay.</li> <li>• Faulty ignition switch.</li> <li>• Faulty clutch switch.</li> <li>• Faulty side-stand switch.</li> <li>• Improper connector contact.</li> <li>• Open circuit in wire harness.</li> </ul>

**Step4**

1) Inspect the starter relay. (☞8-19)

Is the starter relay OK?

YES	Poor starter relay connection.
NO	Faulty starter relay.

**Step5**

The starter motor runs when the transmission is neutral with the side-stand up or down, but does not run when the transmission is in any position other than neutral with the side-stand down.

1) Inspect the side-stand switch. (☞8-20)

Is the side-stand switch OK?

YES	<ul style="list-style-type: none"> <li>• Open circuit in wire harness.</li> <li>• Poor contact of connector.</li> </ul>
NO	<ul style="list-style-type: none"> <li>• Faulty side-stand switch.</li> </ul>

**Engine does not turn though the starter motor runs.**

Faulty starter clutch. (☞3-79)

## STARTER MOTOR REMOVAL AND DISASSEMBLY

- Remove the starter motor and disconnect the starter motor lead wire ①.

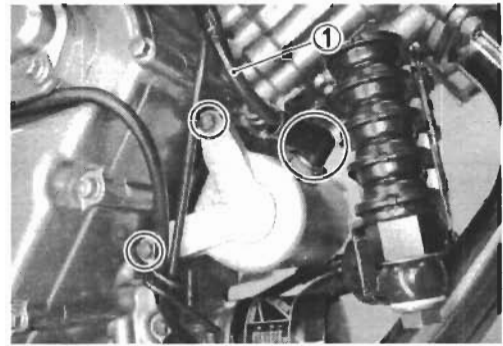

- Disassemble the starter motor as shown in the illustration.

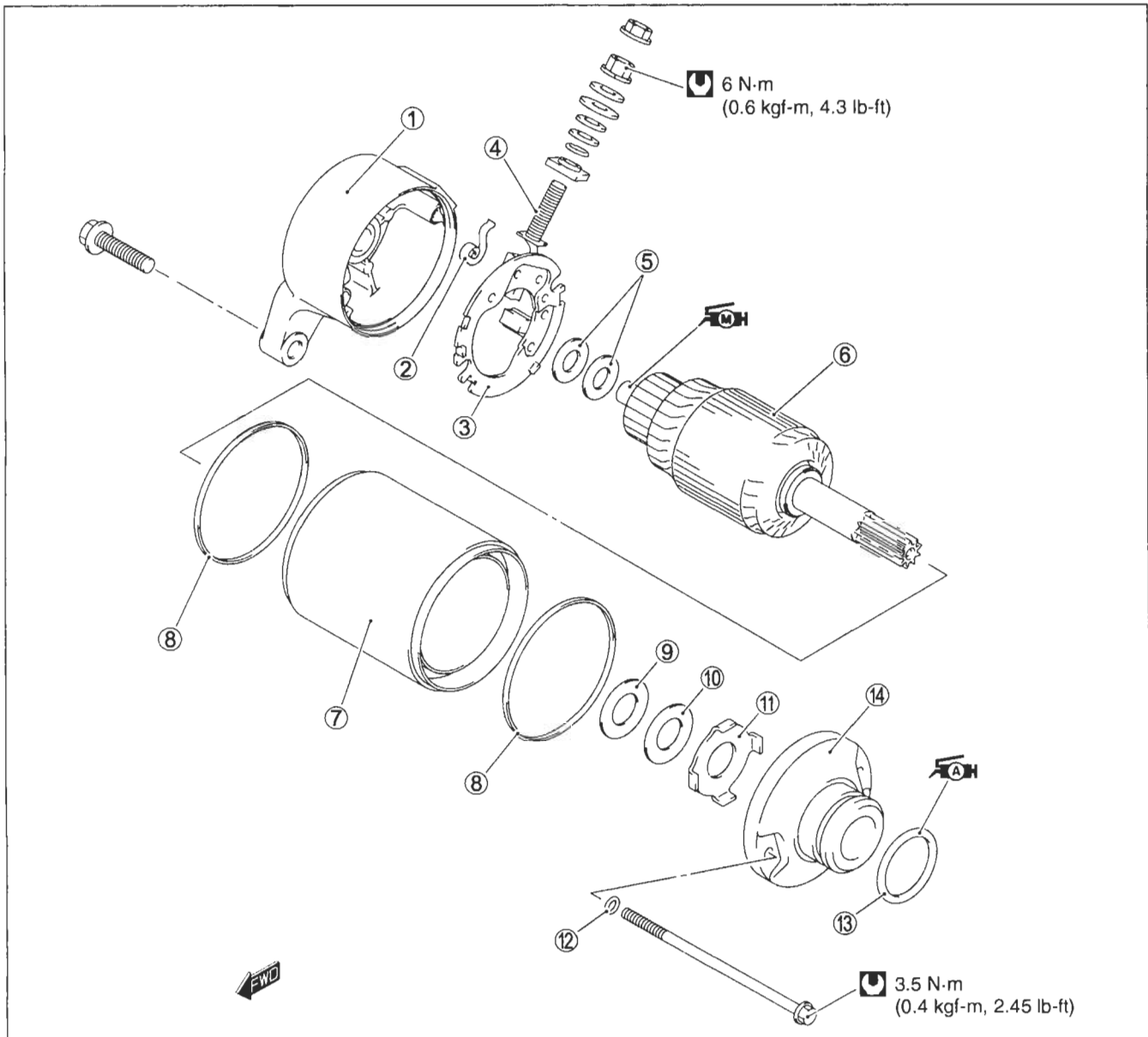

- ① Housing end (rear bracket)
- ② Brush spring (2 pcs)
- ③ Brush holder
- ④ Terminal
- ⑤ Washer

- ⑥ Armature
- ⑦ Starter motor case
- ⑧ Seal ring (2 pcs)
- ⑨ Washer
- ⑩ Slip washer

- ⑪ Thrust stopper
- ⑫ O-ring (2 pcs)
- ⑬ O-ring
- ⑭ Housing end (front bracket)

## STARTER MOTOR INSPECTION

### CARBON BRUSH

Inspect the brushes for abnormal wear, cracks, or smoothness in the brush holder.

If any damage is found, replace the brush assembly with a new one.

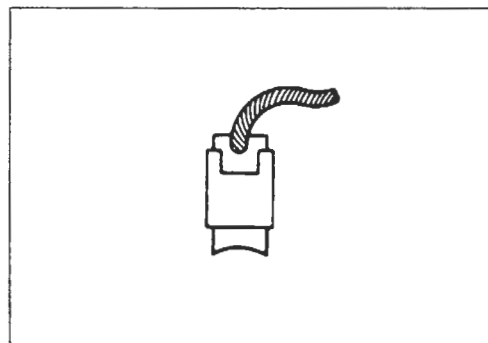

### COMMUTATOR

Inspect the commutator for discoloration, abnormal wear or undercut (A).

If abnormal wear is found, replace the armature with a new one.

If the commutator surface is discolored, polish it with #400 sand paper and wipe it using a clean dry cloth.

If there is no undercut, scrape out the insulator with a saw blade.

- ① Insulator
- ② Segment

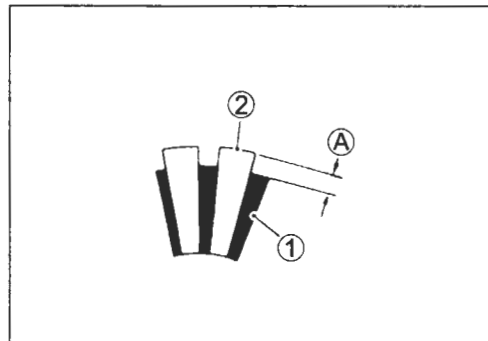

### ARMATURE COIL INSPECTION

Check for continuity between each segment and between each segment and the armature shaft using the multi circuit tester.

If there is no continuity between the segments or there is continuity between the segments and shaft, replace the armature with a new one.

**TOOL** 09900-25008: Multi circuit tester set

**Tester knob indication: Continuity test (•••••)**

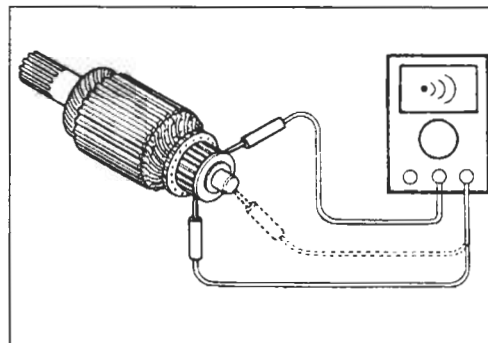

### OIL SEAL INSPECTION

Check the oil seal lip for damage or leakage.

If any damage is found, replace the housing end.

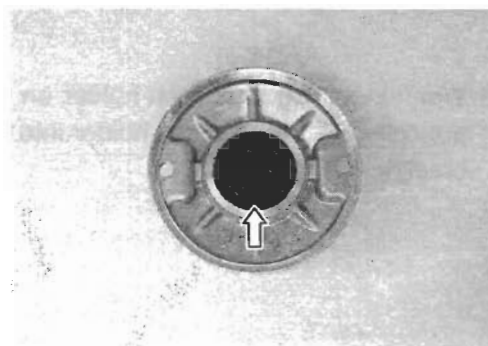

## STARTER MOTOR REASSEMBLY

Reassemble the starter motor in the reverse order of disassembly. Pay attention to the following points:

### CAUTION

Replace the O-rings with the new ones to prevent oil leakage and moisture.

- Apply SUZUKI SUPER GREASE to the lip of the oil seal.

 99000-25030: SUZUKI SUPER GREASE "A" (USA)  
99000-25010: SUZUKI SUPER GREASE "A" (Others)

- Apply a small quantity of SUZUKI MOLY PASTE to the armature shaft.

 99000-25140: SUZUKI MOLY PASTE

- Install the spacer ① to brush terminal.

- When installing the brush holder on the rear bracket, set the projection ② of the brush holder into the groove ① of the rear bracket.

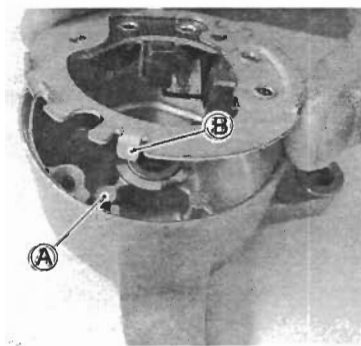
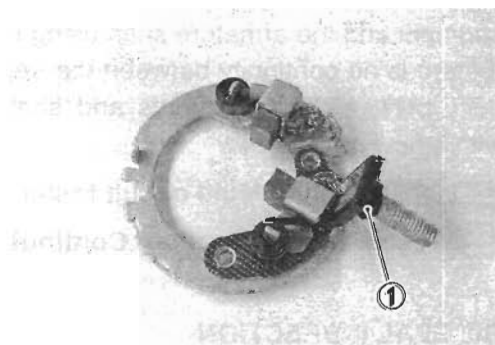
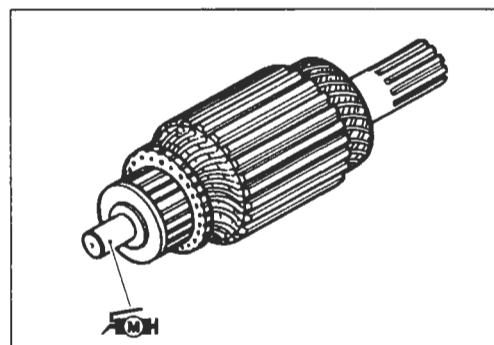
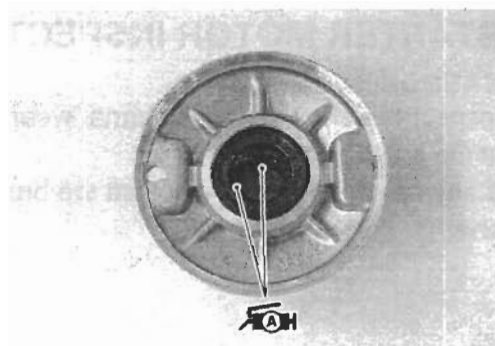

- Install the washers ② (12 × 6.5 × 2), washer ③ (16 × 6.5 × 1), washer ④ (14 × 6.5 × 1) and nut ⑤.

**CAUTION**

Replace the O-rings with the new ones to prevent oil leakage and moisture.

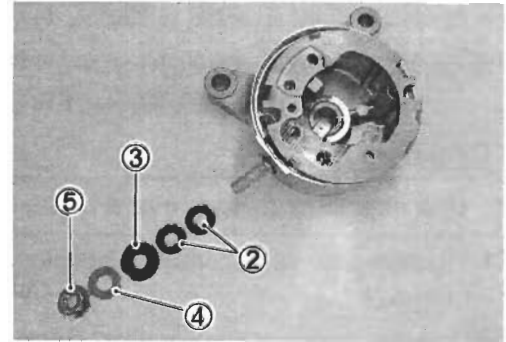

- Install the washers ⑥.

**NOTE:**

The number of washer ⑥ varies according to individual.

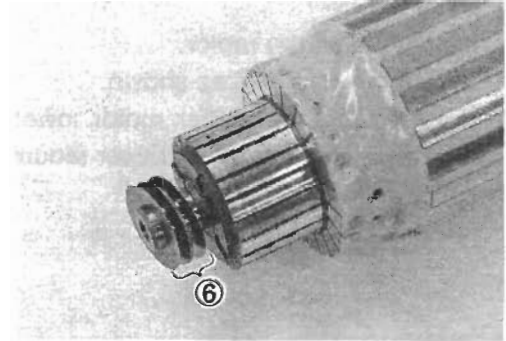

- Install the seal rings ⑧ to starter motor case ⑦.
- When install the rear bracket to starter motor case, align the marks ① on the rear bracket with cut point ② at the starter motor case.

**CAUTION**

Replace the seal rings with the new ones to prevent oil leakage and moisture.

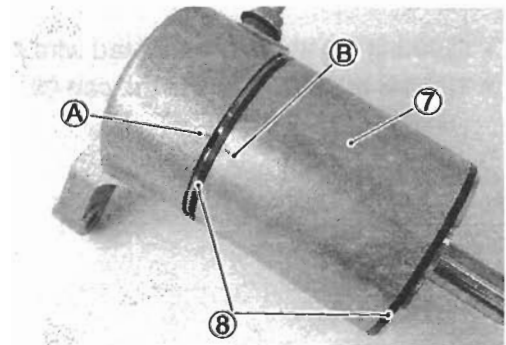

- Install the washers ⑨ slip washer ⑩ and thrust stopper ⑪.

**NOTE:**

The number of washer ⑨ varies according to individual.

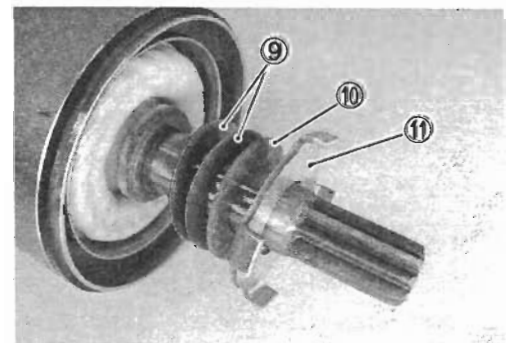

- Install the front bracket.
- Align the marks ③ on the front bracket with the marks ④ on the starter motor case.

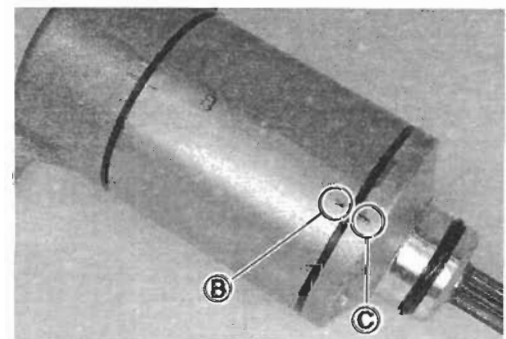

- Apply SUZUKI SUPER GREASE to the starter motor O-rings.



 99000-25030: SUZUKI SUPER GREASE "A" (USA)  
 99000-25010: SUZUKI SUPER GREASE "A" (Others)



**CAUTION**

**Use new O-rings to prevent oil leakage.**

- Tighten the starter motor housing bolts to the specified torque.

 **Starter motor housing bolt: 3.5 N·m (0.4 kgf·m 2.45 lb-ft)**

- Install the starter motor.
- Install the clamp  as shown.
- First tighten the starter motor lower mounting bolt , then tighten the starter motor upper mounting bolt .

- Connect the starter motor read wire as shown.
- Tighten the nut  and fit the cap .

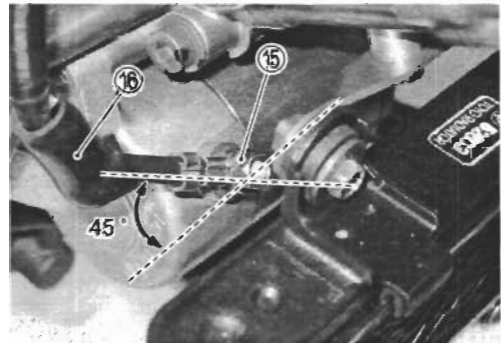
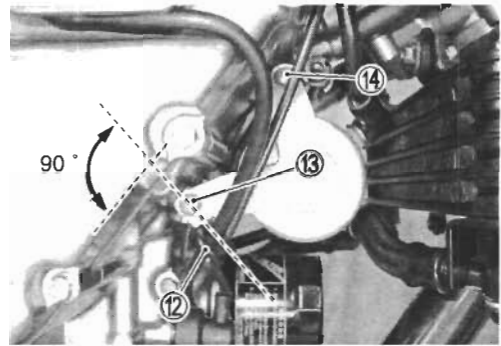
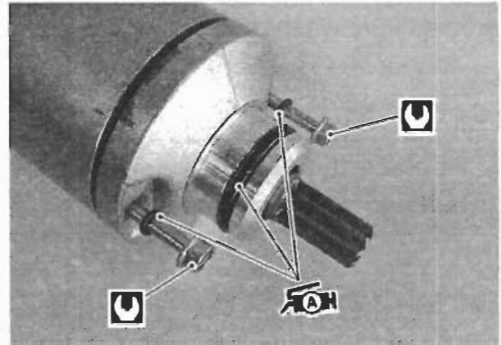

## STARTER RELAY INSPECTION

- Remove the seat. (☞7-4)
  - Disconnect the battery  $\ominus$  lead wire from the battery.
  - Remove the starter relay cover ①.
  - Disconnect the starter relay coupler ②.
- 
- Disconnect the starter motor lead wire ③ and battery lead wire ④.
  - Remove the starter relay ⑤.

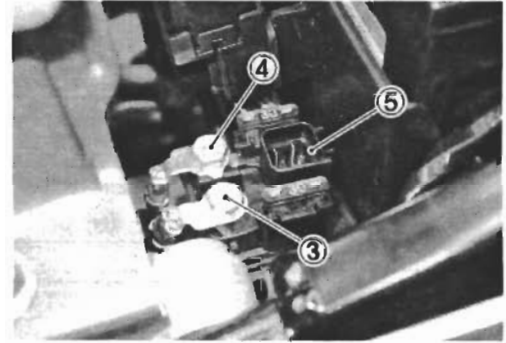
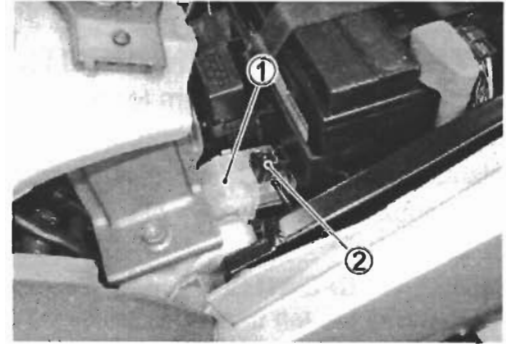

Apply 12 V to (A) and (B) terminals and check for continuity between the positive and negative terminals using the multi circuit tester. If the starter relay clicks and continuity is found, the relay is ok.

**TOOL** 09900-25008: Multi circuit tester set

**Tester knob indication: Continuity test (•|||)**

### CAUTION

Do not apply a battery voltage to the starter relay for five seconds and more, since the relay coil may over-heat and get damaged.

Measure the relay coil resistance between the terminals using the multi circuit tester. If the resistance is not within the specified value, replace the starter relay with a new one.

**TOOL** 09900-25008: Multi circuit tester set

**Tester knob indication: Resistance ( $\Omega$ )**

**DATA** Starter relay resistance: 3 – 6  $\Omega$

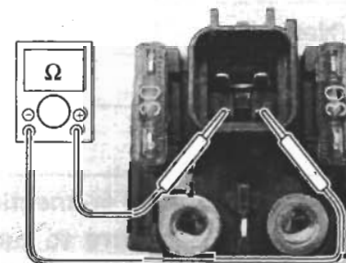
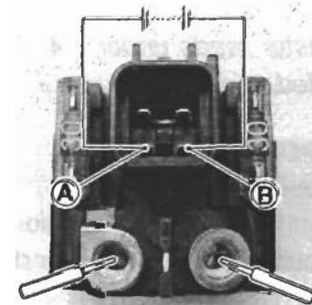



## SIDE-STAND/IGNITION INTERLOCK SYSTEM PARTS INSPECTION

Check the interlock system for proper operation. If the interlock system does not operate properly, check each component for damage or abnormalities. If any abnormality is found, replace the component with a new one.

### SIDE-STAND SWITCH

- Remove the left frame cover. (☞7-5)
- Disconnect the side-stand switch coupler ① and measure the voltage between Black/White and Green lead wires.

**TOOL** 09900-25008: Multi circuit tester set

**Tester knob indication: Diode test (↔)**

	Black/White (+ probe)	Green (- probe)
Side-stand up ①	0.4 – 0.6 V	
Side-stand down ②	1.4 V and more (Tester's battery voltage)	

**NOTE:**

If the tester reads under 1.4 V when the tester probes are not connected, replace its battery.

### GEAR POSITION SWITCH

- Remove the left frame cover. (☞7-5)
- Disconnect the gear position switch coupler and check the continuity between Blue and Black/White with the transmission in "NEUTRAL".

**TOOL** 09900-25008: Multi circuit tester set

**Tester knob indication: Continuity test (••))**

	Blue	Black/White
ON (Neutral)	○ — ○	
OFF (Expect neutral)		

**CAUTION**

When disconnecting and connecting the gear position switch coupler, make sure to turn OFF the ignition switch, or electronic parts may get damaged.

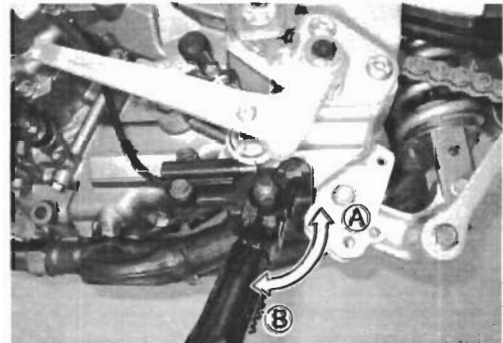
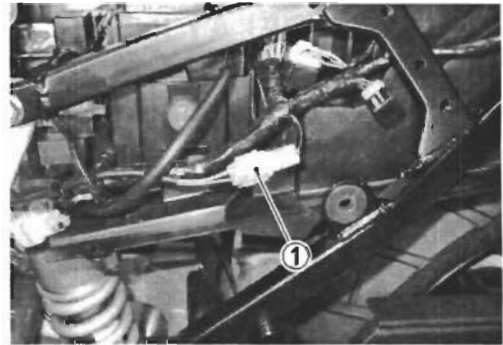

- Connect the gear position switch coupler to the wiring harness.
- Turn the ignition switch to “ON” position and side-stand to upright position.
- Insert the needle pointed probes to the gear position switch coupler.

Measure the voltage between Pink and B/W lead wires using the multi circuit tester when shifting the gearshift lever from low to top.

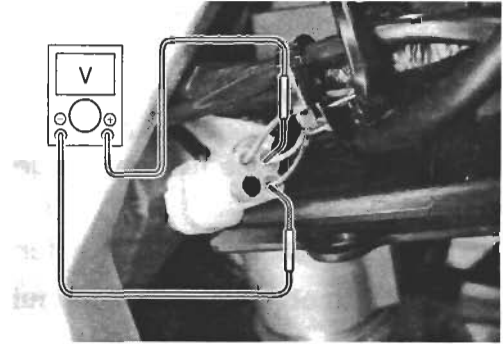

- TOOL** 09900-25008: Multi circuit tester set
- 09900-25009: Needle pointed probe set

**V** Tester knob indication: voltage (V)

**DATA** Gear position switch voltage

Gear position	1st	2nd	3rd	4th	5th	6th
Voltage	Approx. 1.36 V	Approx. 1.77 V	Approx. 2.49 V	Approx. 3.23 V	Approx. 4.10 V	Approx. 4.55 V

**NOTE:**

- \* When connecting the multi circuit tester, use the needle pointed probe to the back side of the lead wire coupler and connect the probes of tester to them.
- \* Use a needle pointed probe outer diameter being below 0.5 mm to prevent the rubber of the water proof coupler from damage.

### TURN SIGNAL/SIDE-STAND RELAY REMOVAL AND INSTALLATION

The turn signal/side-stand relay is composed of the turn signal relay, side-stand relay and diode.

- Remove the seat. (☞7-4)
- Remove the turn signal/side-stand relay ①.
- Install the turn signal/side-stand relay in the reverse order of removal.

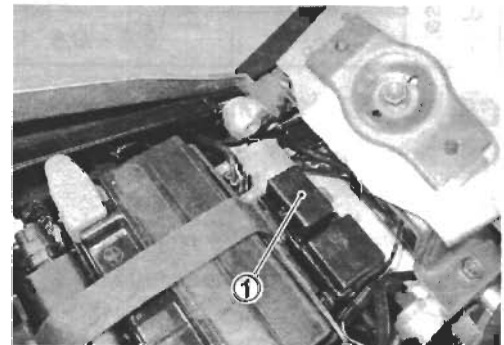

**SIDE-STAND RELAY INSPECTION**

First check the insulation between ④ and ⑤ terminals with the tester. Then apply 12 V to terminals ④ and ③ (+ to ④ and - to ③) and check the continuity between ④ and ⑤. If there is no continuity, replace the turn signal/side-stand relay with a new one.

**TOOL 09900-25008: Multi circuit tester set**

**Tester knob indication: Continuity test (••••)**

- ① Diode
- ② Side-stand relay
- ③ Turn signal relay

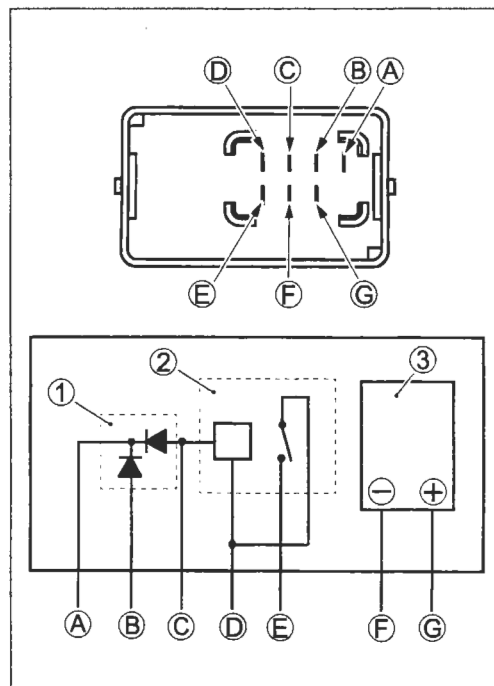

**DIODE INSPECTION**

Measure the voltage between the terminals using the multi circuit tester. Refer to the following table.

Unit: V

		⊕ Probe of tester to:	
		③, ②	①
① Probe of tester to:	③, ②		1.4 V and more
	①	0.4 - 0.6	

**TOOL 09900-25008: Multi circuit tester set**

**Tester knob indication: Diode test (—|—)**

**NOTE:**

If the multi circuit tester reads 1.4 V and below when the tester probes are not connected, replace its battery.

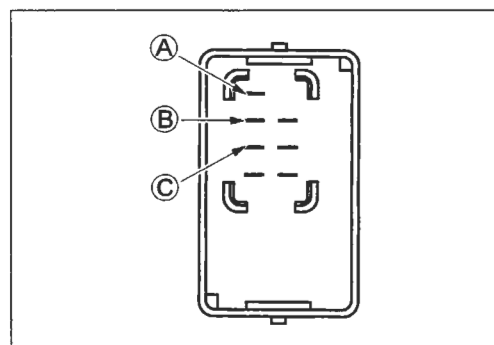

## IGNITION SYSTEM

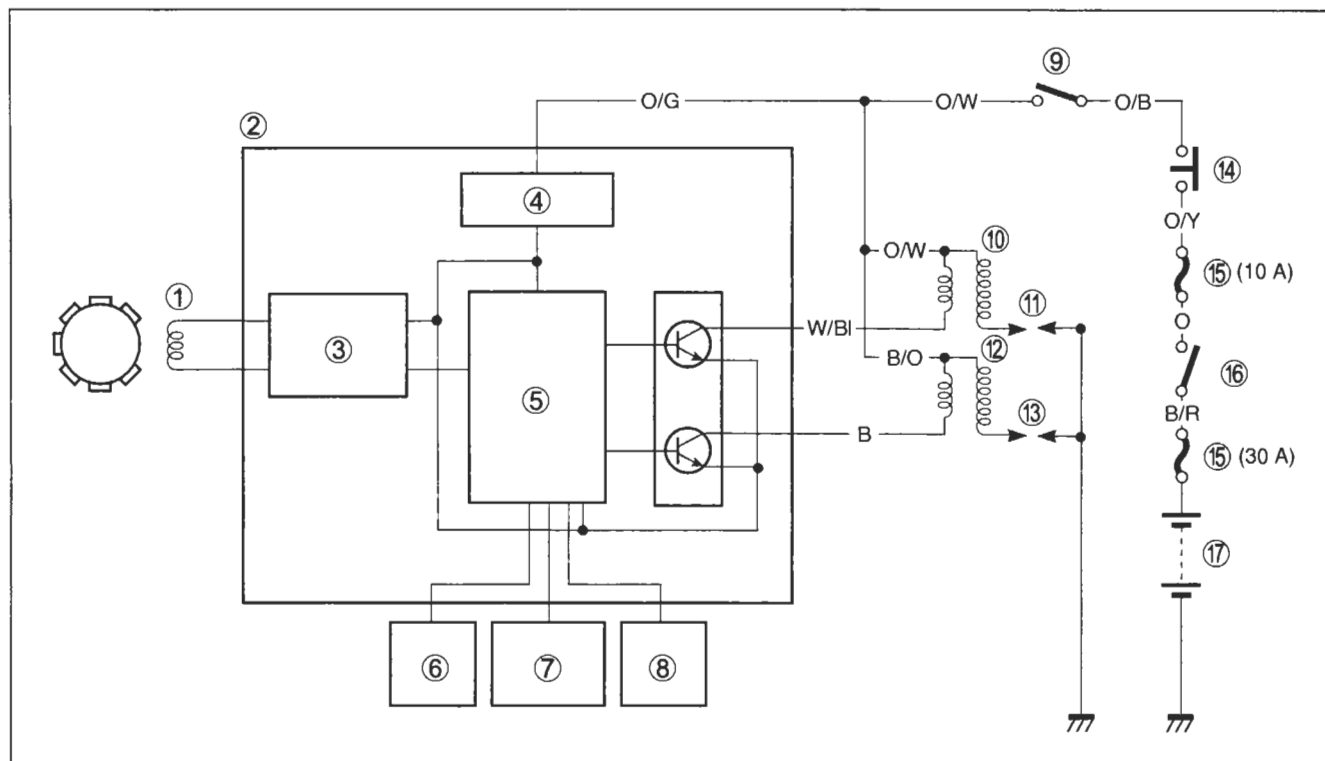

- ① CKP sensor    ② ECM    ③ Wave form arrangement circuit    ④ Power source circuit    ⑤ CPU  
 ⑥ TP sensor    ⑦ ECT sensor    ⑧ Gear position switch    ⑨ Engine stop switch    ⑩ Ignition coil #1  
 ⑪ Spark plug #1    ⑫ Ignition coil #2    ⑬ Spark plug #2    ⑭ Side-stand relay    ⑮ Fuse  
 ⑯ Ignition switch    ⑰ Battery

## TROUBLESHOOTING

### No spark or poor spark

Make sure the engine stop switch is in the "RUN" position and side-stand is in up-right position. Make sure the fuse is not blown and the battery is fully-charged before diagnosing.

#### Step1

- 1) Check the ignition system couplers for poor connections.

Is there connection in the ignition switch couplers?

YES	Go to Step2.
NO	Improper coupler connection.

#### Step 2

- 1) Measure the battery voltage between input lead wire (O/G and B/W) at the ECM with the ignition switch in the "ON" position.

Is the voltage OK?

YES	Go to Step3.
NO	<ul style="list-style-type: none"> <li>• Faulty ignition switch.</li> <li>• Faulty turn signal/side-stand relay.</li> <li>• Faulty engine stop switch.</li> <li>• Broken wire harness or poor connection of related circuit couplers.</li> </ul>

**Step3**

1) Measure the ignition coil primary peak voltage. (☞ 8-25)

**NOTE:**

*The ignition coil peak voltage inspection method is applicable only with the multi circuit tester and peak volt adaptor.*

Is the peak voltage OK?

YES	Go to Step4.
NO	Go to Step5.

**Step4**

1) Inspect the spark plug. (☞ 2-6)

Is the spark plug OK?

YES	<ul style="list-style-type: none"> <li>• Improper spark plug connection.</li> <li>• Go to Step5.</li> </ul>
NO	Faulty spark plug.

**Step5**

1) Inspect the ignition coil. (☞ 8-26)

Is the ignition coil OK?

YES	Go to Step6.
NO	Faulty ignition coil.

**Step6**

1) Measure the CKP sensor peak voltage and its resistance.

**NOTE:**

*The CKP sensor peak voltage inspection is applicable only with the multi circuit tester and peak volt adaptor.*

Is the peak voltage and resistance OK?

YES	<ul style="list-style-type: none"> <li>• Faulty ECM.</li> <li>• Faulty wire harness.</li> <li>• Improper ignition coupler connection.</li> </ul>
NO	Faulty CKP sensor.

## INSPECTION

### IGNITION COIL PRIMARY PEAK VOLTAGE

- Lift and support the fuel tank. (☞ 5-7)
- Remove the radiator lower mounting bolt and move the radiator lower side to forward.
- Disconnect the two spark plug caps.
- Connect the new two spark plugs to each spark plug cap and ground them.

#### NOTE:

Make sure that all couplers and spark plugs are connected properly and the battery used is in fully-charged condition.

Measure the No.1 and No.2 ignition coils primary peak voltage in the following procedure.

- Connect the multi circuit tester with peak voltage adaptor as follows.

- No.1 ignition coil:    ⊕ Probe: White/Blue terminal  
                                  ⊖ Probe: Ground
- No.2 ignition coil:    ⊕ Probe: Black terminal  
                                  ⊖ Probe: Ground

- ① Peak volt adaptor
- ② Ignition coil (No.1 or No.2)
- ③ New spark plug
- ④ ECM
- ⑤ Battery

#### NOTE:

Do not disconnect the ignition coil primary wire coupler.

 09900-25008: Multi circuit tester set

#### CAUTION

**Before using the multi circuit tester and peak volt adaptor, be sure to refer to the appropriate instruction manual.**

- Shift the transmission into the neutral and then turn the ignition switch to the "ON" position.
- Pull the clutch lever.
- Push the starter button and allow the engine to crank for a few seconds, and then measure the ignition coil primary peak voltage.

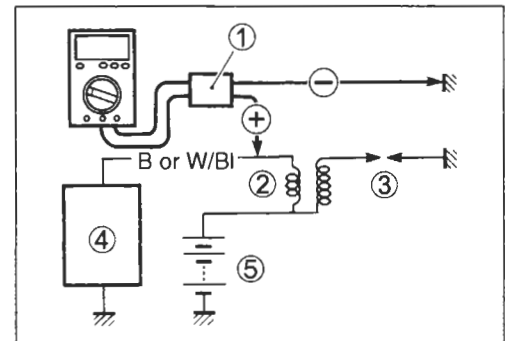
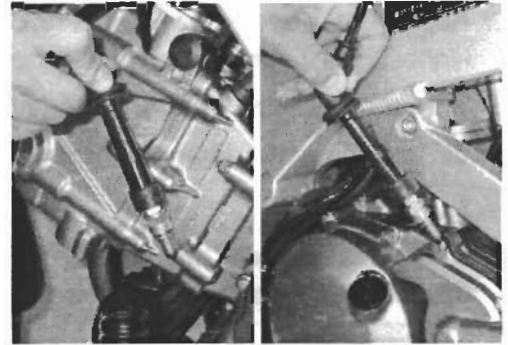

- Repeat the above procedure a few times and measure the highest ignition coil primary peak voltage.

 **Tester knob indication: Voltage (---)**

**DATA** Ignition coil primary peak voltage: 150 V and more

**⚠ WARNING**

**While testing, do not touch the tester probes and spark plugs to prevent receiving an electric shock.**

- If the peak voltage is lower than the specified values, inspect the ignition coil. (☞ 8-26)

**IGNITION COIL RESISTANCE**

- Lift and support the fuel tank. (☞ 5-7)
- Disconnect the spark plug caps and ignition coil lead wires.

Measure the ignition coil resistance in both the primary and secondary windings. If the resistance is not within the standard range, replace the ignition coil with a new one.

**TOOL** 09900-25008: Multi circuit tester set

 **Tester knob indication: Resistance ( $\Omega$ )**

**DATA** Ignition coil resistance

**Primary : 2 – 5  $\Omega$  (+ terminal – - terminal)**

**Secondary : 24 – 37 k $\Omega$  (Plug cap – + terminal)**

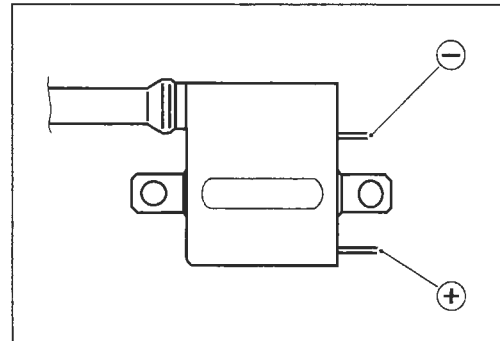
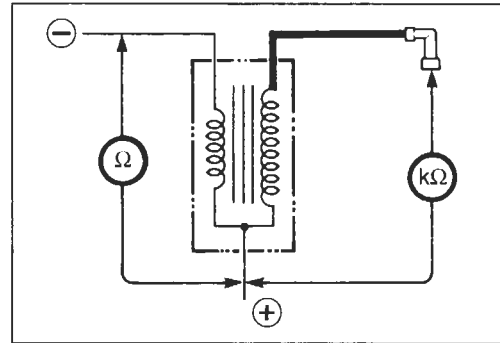

**CKP SENSOR PEAK VOLTAGE**

- Remove the seat. (7-4)
- Disconnect the ECM coupler.

**NOTE:**

Make sure that all of the couplers are connected properly and the battery used is in fully-charged condition.

Measure the CKP sensor peak voltage in the following procedures.

- Connect the multi circuit tester with peak volt adaptor as follows.
  - ⊕ Probe: White lead wire
  - ⊖ Probe: Black/White lead wire

**TOOL** 09900-25008: Multi circuit tester set

**CAUTION**

Before using the multi circuit tester and peak volt adaptor, be sure to refer to the appropriate instruction manual.

- Shift the transmission into the neutral, and then turn the ignition switch to the "ON" position.
- Pull the clutch lever.
- Push the starter button and allow the engine to crank for a few seconds, and then measure the CKP sensor peak voltage.
- Repeat the above procedure a few times and measure the highest peak voltage.

- ① CKP sensor
- ② CKP sensor coupler
- ③ ECM coupler
- ④ Peak volt adaptor

**Tester knob indication: Voltage (---)**

**DATA** CKP sensor peak voltage: 3.7 V and more

If the peak voltage is less than the specified values, check the peak voltage at the CKP sensor lead wire coupler.

- Remove the right cowling. (7-5)
- Disconnect the CKP sensor lead wire coupler and connect the multi circuit tester with the peak volt adaptor.
  - ⊕ Probe: White lead wire
  - ⊖ Probe: Green lead wire
- Measure the CKP sensor peak voltage at the CKP sensor lead wire coupler in the same manner as on the ECM coupler.

**Tester knob indication: Voltage (---)**

**DATA** CKP sensor peak voltage: 3.7 V and more

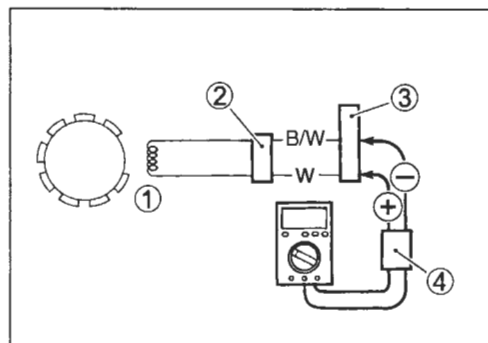
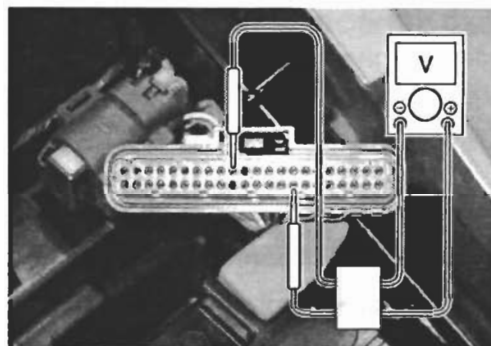
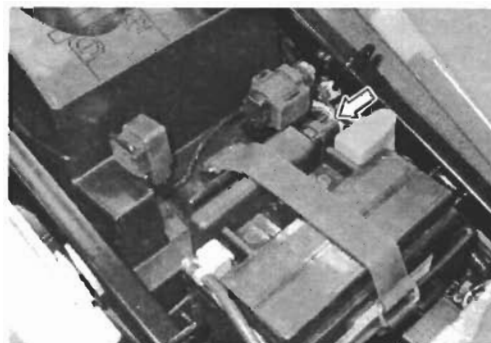



If the peak voltage on the CKP sensor lead wire coupler is OK but on the ECM coupler is out of specification, the wire harness must be replaced. If both peak voltages are out of specification, the CKP sensor must be replaced and re-checked.

- ⑤ CKP sensor
- ⑥ CKP sensor coupler
- ⑦ Peak volt adaptor

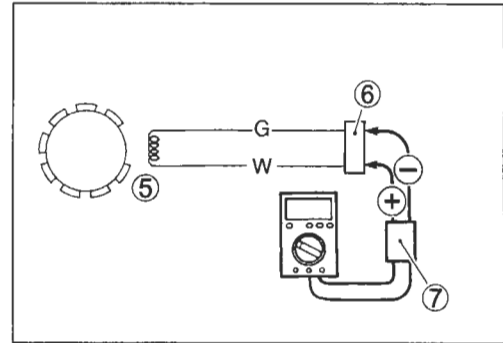

### CKP SENSOR RESISTANCE

Measure the resistance between the lead wires and ground. If the resistance is not specified value, the CKP sensor must be replaced.

- ① CKP sensor
- ② CKP sensor coupler

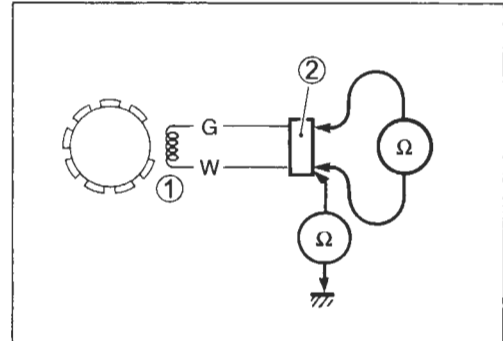

**TOOL** 09900-25008: Multi circuit tester set

**TESTER** Tester knob indication: Resistance ( $\Omega$ )

**DATA** CKP sensor resistance: 130 – 240  $\Omega$  (White – Green)  
 $\infty$   $\Omega$  (White – Ground)

## COMBINATION METER

### REMOVAL AND DISASSEMBLY

- Disconnect the battery  $\ominus$  lead wire.
- Remove the combination meter panel. (➔7-6).
- Remove the combination meter ①.

#### CAUTION

When disconnecting and connecting the combination meter coupler, make sure to turn OFF the ignition switch, or electronic parts may get damaged.

- Disassemble the combination meter as follows.

#### CAUTION

Do not attempt to disassemble the combination meter unit.

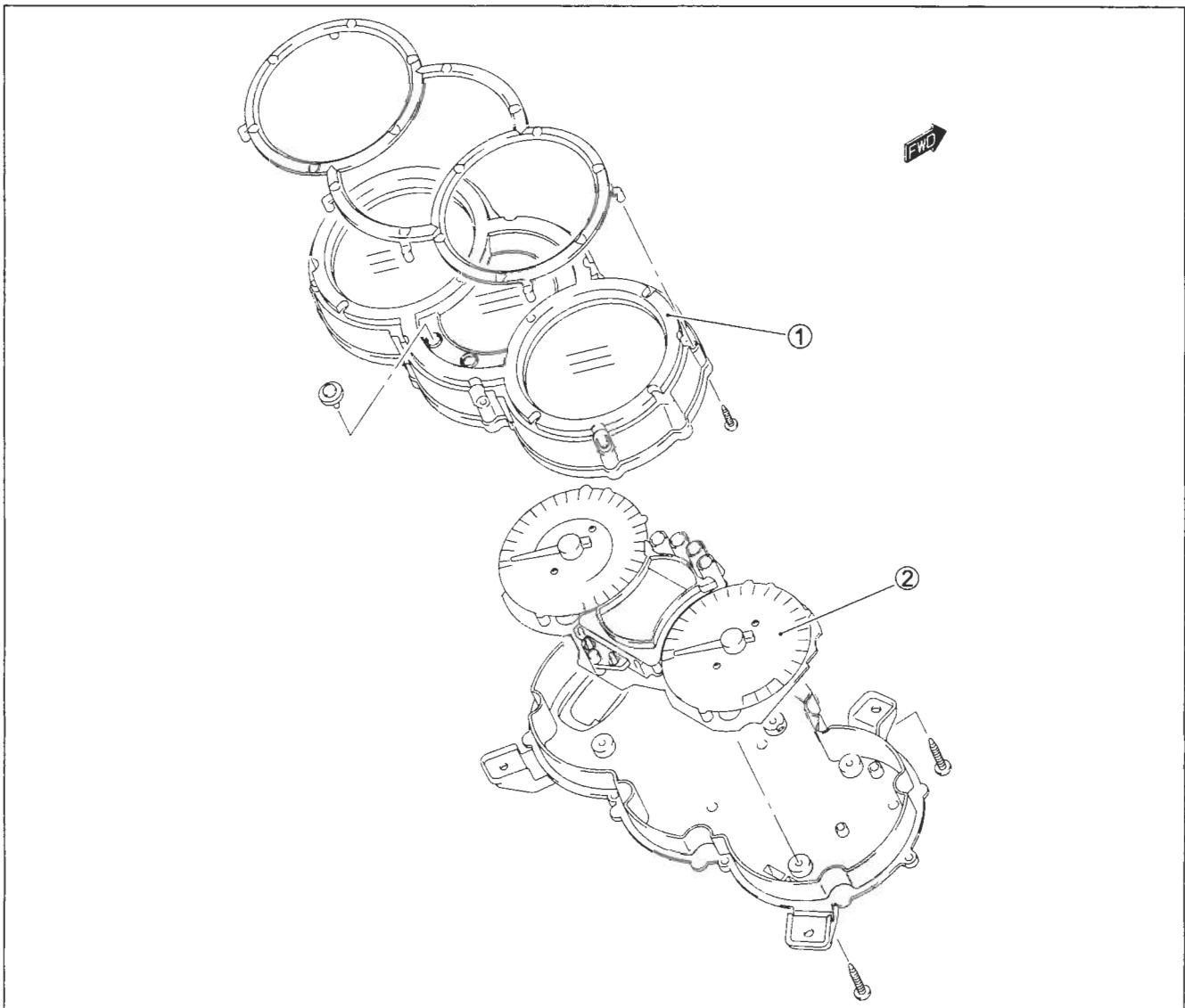
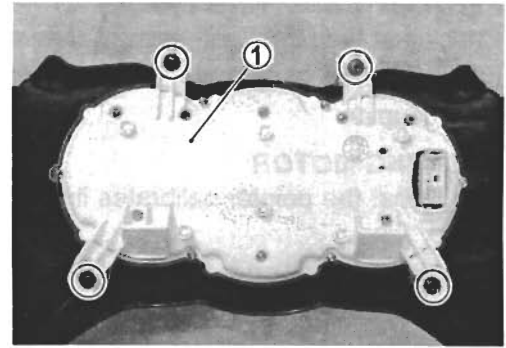

① Combination meter cover

② Combination meter unit

## INSPECTION

### LED (LIGHT EMITTING DIODE)

Check that the LED lights immediately after turning the ignition switch on.

If the LED fails in operation, replace the combination meter unit with a new one after checking its wire harness/coupler.

### STEPPING MOTOR

Check that the pointer calibrates itself immediately after turning the ignition switch on and stops at starting point.

If abnormal condition is found, replace the combination meter unit with a new one after checking its wire harness/coupler.

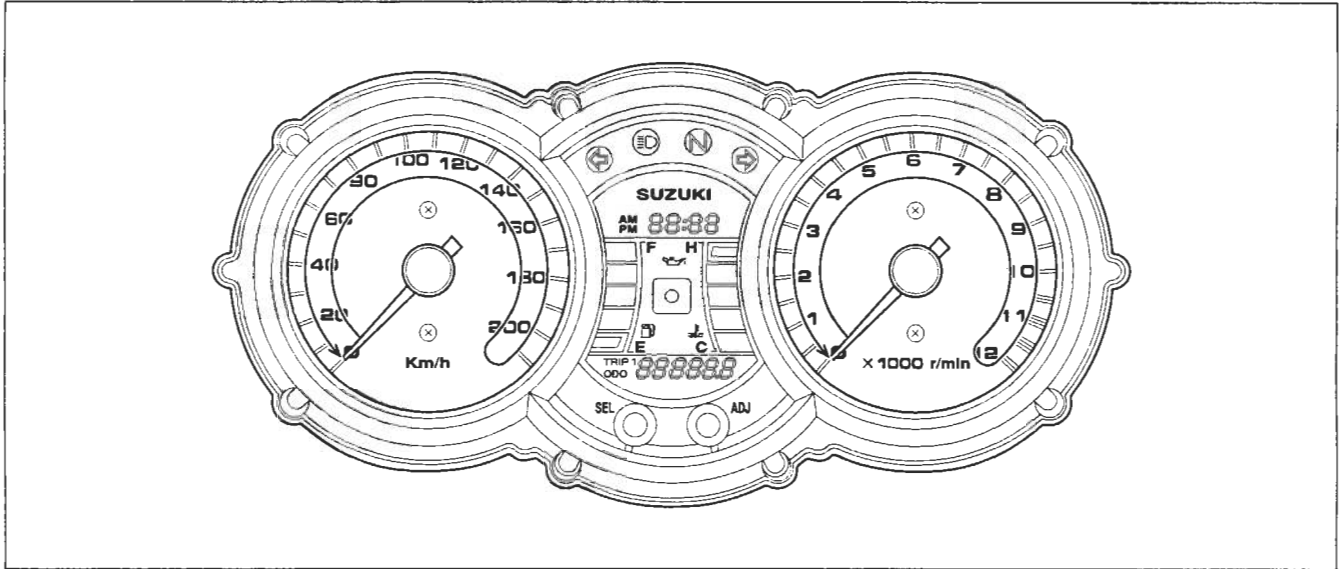

#### NOTE:

The pointer may not return to the proper position even turning the ignition switch on under low temperature condition. In that case, you can reset the pointer to the proper position by following the instruction below:

- 1) With the ADJ switch (A) pressed, turn the ignition switch on.
- 2) Keep pushing the ADJ switch (A) for 3 to 5 seconds.
- 3) Push the ADJ switch (A) twice (within 1 second). → Reset

\* Complete the operation within 10 seconds after the ignition switch has been turned on.

Time	Ignition switch	ADJ switch (A)
0	OFF	PUSH
•	ON	↓
•		
3 sec		↓
•		Release
5 sec		
•		Push
•		
•		Push → Reset
•		
10 sec	↓	

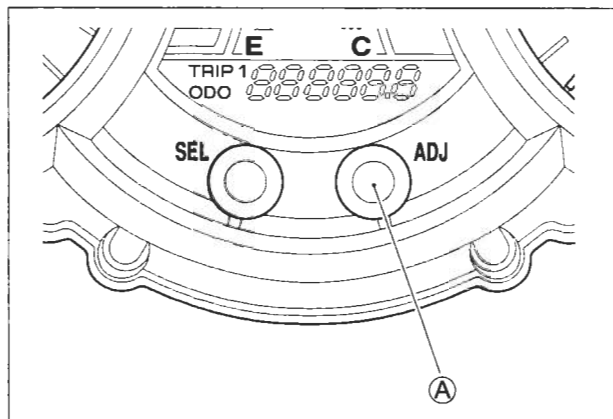

(A) ADJ SWITCH

Pointer will return to the starting point right after the completion of the operation. In the case of the pointer not returning to the proper position after doing above, replace the combination meter unit.

**ODOMETER**

The odometer indicates "-----" when the odometer is faulty.  
Replace the combination meter unit with a new one.

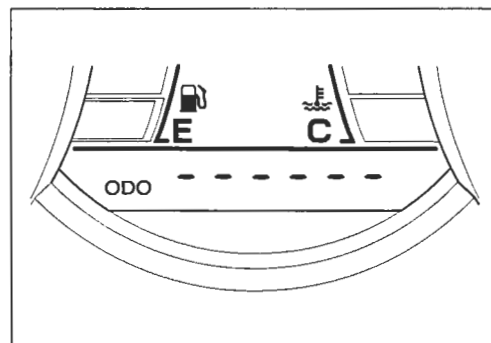
**TRIP METER**

The trip meter indicates "----.-" when the trip meter is faulty.  
In case the odometer works normaly, perform the trip meter reset. If the trip meter isn't restored after above reset, replace the combination meter unit with a new one.

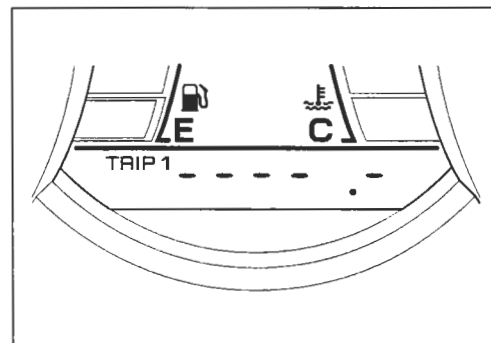
**TRIP METER RESET PROCEDURE**

1. Turn the ignition "ON".
2. Select the trip meter by pushing the SEL switch (A).
3. Push the ADJ switch (B) for 2 seconds.

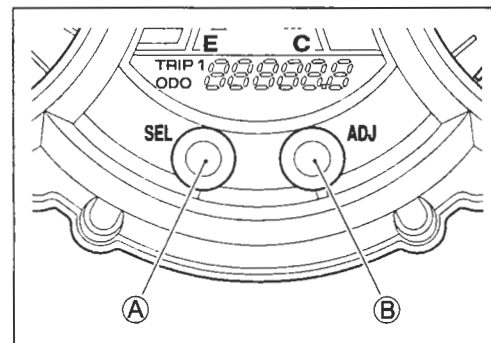

## INDICATORS

### ENGINE COOLANT TEMPERATURE METER INSPECTION

- Disconnect the ECT sensor coupler ①.

#### CAUTION

When connecting and disconnecting the ECT sensor lead wire coupler, make sure to turn OFF the ignition switch, or electronic parts may get damaged.

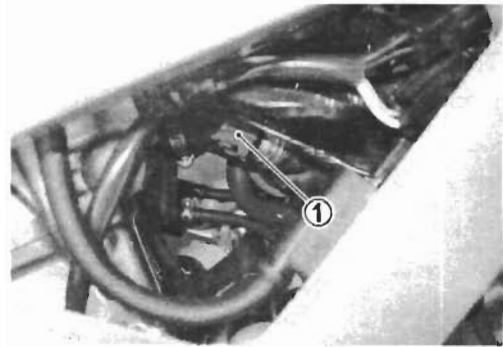

- Connect the variable resistor (A) between the terminals.
- Turn the ignition switch "ON".
- Check the display of engine coolant temperature meter as shown below. If any abnormality is found, replace the combination meter with a new one.

- (A) Variable resistor
- (B) ECT sensor

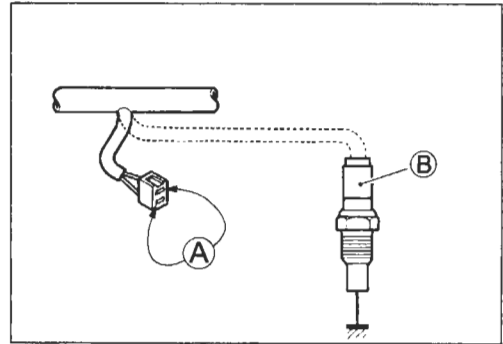

Water temperature	39 °C and below	40 – 59 °C	60 – 79 °C	80 – 111 °C
Resistance	1.148 kΩ and more	1.148 – 0.587 kΩ	0.587 – 0.188 kΩ	0.188 – 0.140 kΩ
Engine coolant temperature meter				

Water temperature	112 – 119 °C	120 °C and over	122 °C and over
Resistance	0.140 – 0.116 kΩ	0.116 kΩ and less	0.111 kΩ and less
Engine coolant temperature meter			

**FUEL LEVEL GAUGE INSPECTION**

- Remove the fuel tank. (☞ 5-7)
- Remove the fuel pump. (☞ 5-10)

Measure the resistance at each fuel level gauge float position. If the resistance is incorrect, replace the fuel level gauge with a new one.

Float position	Resistance
Ⓐ "F" (Full)	Approx. 4 $\Omega$
Ⓑ "E" (Empty)	Approx. 182 $\Omega$

**TOOL** 09900-25008: Multi circuit tester set

**Tester knob indication: Resistance ( $\Omega$ )**

- Install the fuel pump. (☞ 5-12)

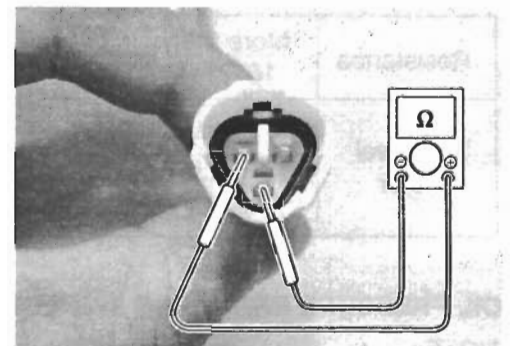
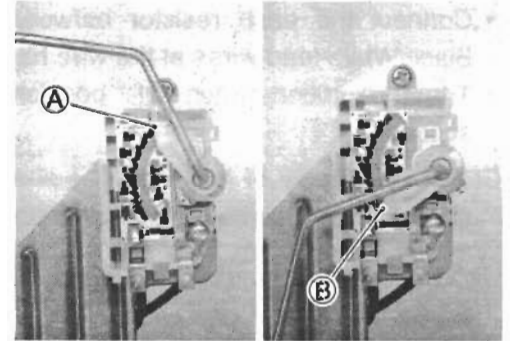
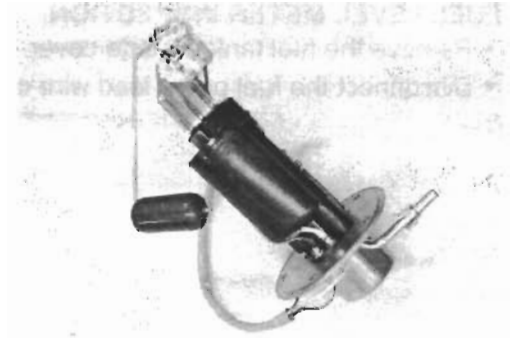

**FUEL LEVEL METER INSPECTION**

- Remove the fuel tank left side cover. (☞ 7-4)
- Disconnect the fuel pump lead wire coupler.



- Connect the each resistor between the Yellow/Black and Black/White lead wires at the wire harness.
- Turn the ignition switch "ON" position and wait for approx. 40 seconds.

Check the display of fuel meter as shown below, If any abnormality is found, replace the combination meter with a new one.

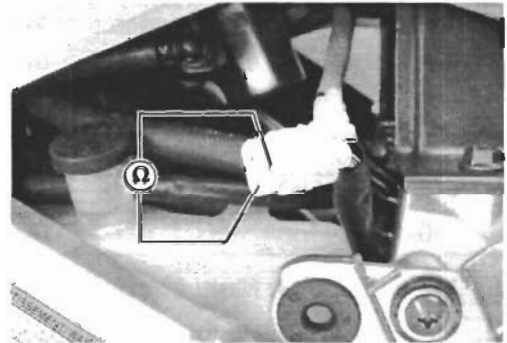

Resistance	More than 167.0 Ω	87.5 – 167.0 Ω	50.0 – 87.5 Ω	26.0 – 50.0 Ω	6.5 – 26.0 Ω	6.5 Ω and less
Fuel level meter						

**OIL PRESSURE INDICATOR INSPECTION**

**NOTE:**  
Before inspecting the oil pressure switch, check the engine oil level. (☞ 2-13)

- Disconnect the oil pressure switch lead wire from the oil pressure switch.
- Turn the ignition switch "ON" position.



Check if the oil pressure indicator will light, when grounding the oil pressure switch lead wire ①.

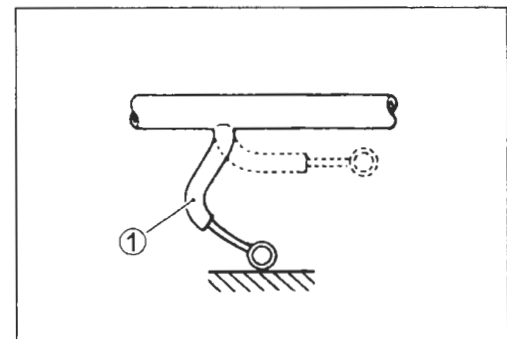

### SPEEDOMETER AND SPEED SENSOR

If the speedometer, odometer or trip meter does not function properly, inspect the speed sensor and connection of coupler ①. If the speed sensor and connection are all right, replace the meter with a new one.



### SPEED SENSOR REMOVAL AND INSTALLATION

- Remove the front wheel. (7-10)
- Disconnect the speed sensor coupler. (8-35)
- Remove the speed sensor.
- Install the speed sensor in the reverse order of removal.

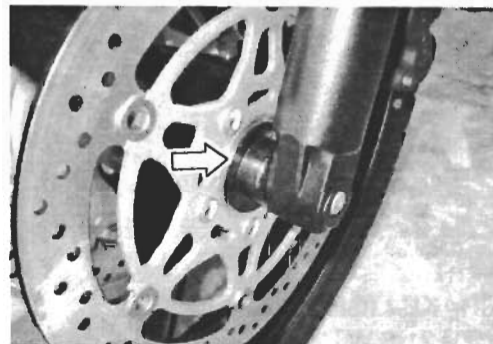

### SPEED SENSOR INSPECTION

- Connect the four 1.5 V dry cells, 10 k $\Omega$  resistance and the tester to the speed sensor lead wire coupler as shown.

 **09900-25008: Multi-circuit tester set**

 **Tester knob indication: Voltage (V)**

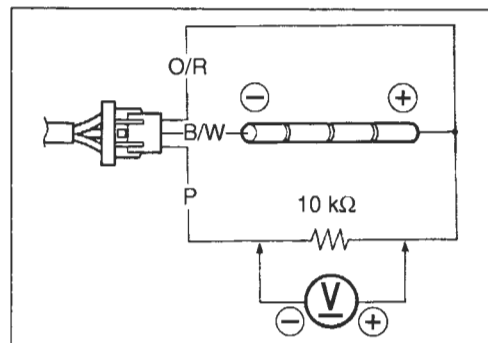

Lift and turn the front wheel and check that voltage varies between 0 – 6 V.

If any abnormal condition is noted, replace the sensor.

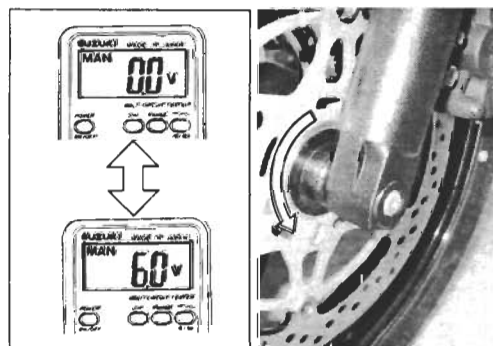



## LAMPS

### HEADLIGHT, BRAKE LIGHT/TAILLIGHT AND TURN SIGNAL LIGHT

#### HEADLIGHT

12 V 60/55 W

12 V 60/55 W + 5 W

Ⓐ ONLY E-02, 19

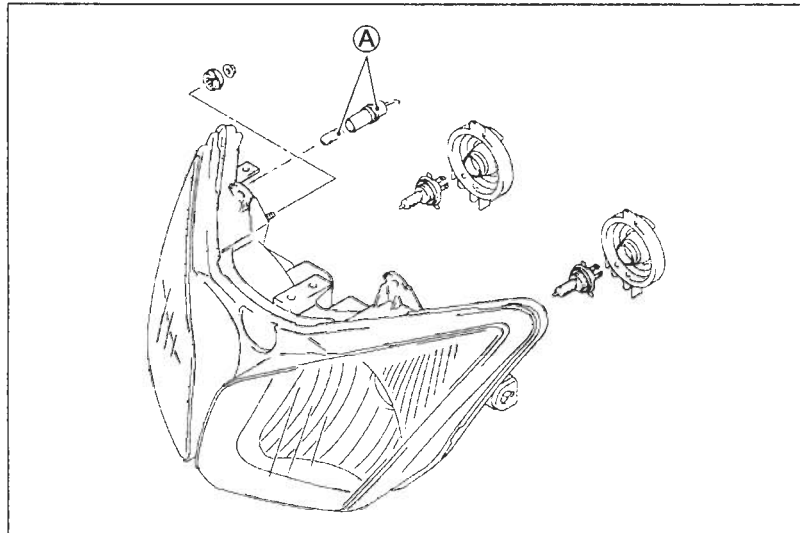

#### BRAKE LIGHT/TAIL LIGHT

12 V 21/5 W

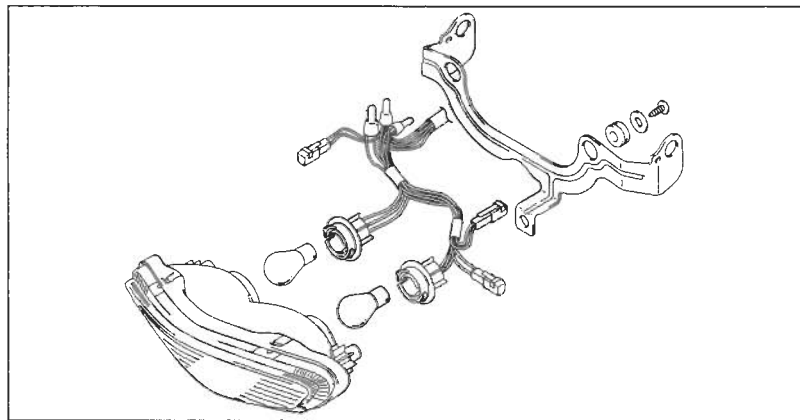

#### TURN SIGNAL LIGHT

12 V 21 W

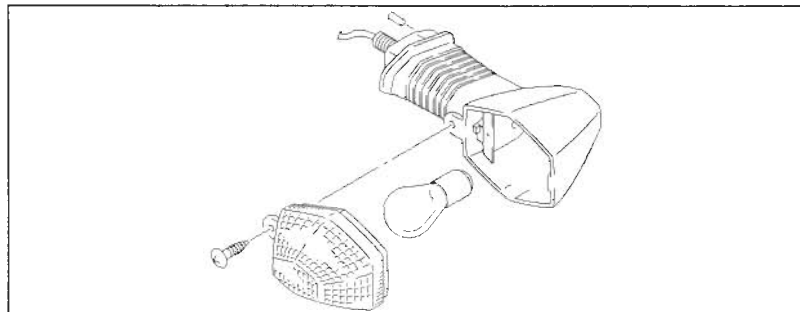

#### HEADLIGHT BEAM ADJUSTMENT

- Adjust the headlight beam, both vertical and horizontal.

Ⓐ: Vertical adjuster

Ⓑ: Horizontal adjuster

#### NOTE:

To adjust the headlight beam, adjust the beam horizontally first, then adjust the vertically.

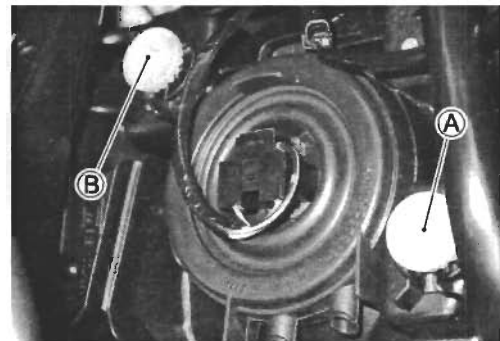

## RELAYS

### TURN SIGNAL/SIDE-STAND RELAY

The turn signal/side-stand relay is composed of the turn signal relay, side-stand relay and diode.

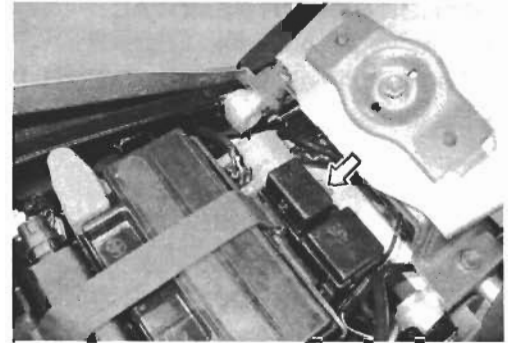

#### INSPECTION

Before removing the turn signal/side-stand relay, check the operation of the turn signal light.

If the turn signal light does not illuminate, inspect the bulb, turn signal switch and circuit connection.

If the bulb, turn signal switch and circuit connection are OK, the turn signal relay may be faulty; therefore, replace the turn signal/side-stand relay with a new one.

#### NOTE:

- \* Make sure that the battery is fully charged.
- \* Refer to the page 8-22 for the side-stand relay and diode inspection.

- ① Diode
- ② Side-stand relay
- ③ Turn signal relay

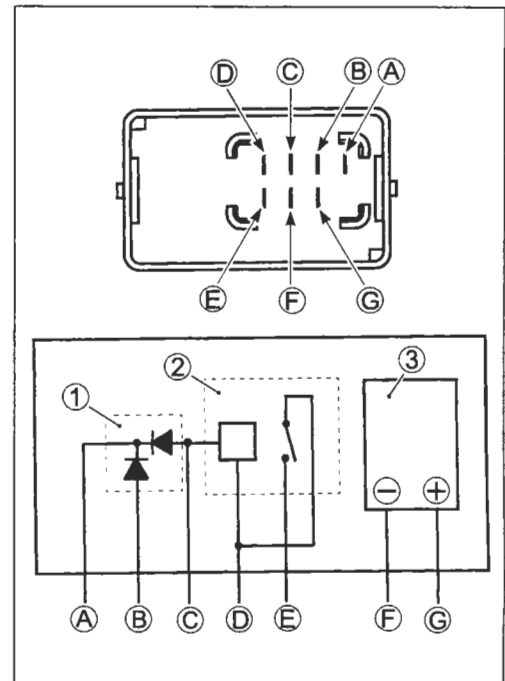

### STARTER RELAY

( 8-19)

### FUEL PUMP RELAY

( 5-10)

## SWITCHES

### IGNITION SWITCH REMOVAL

- Remove the fuel tank. (☞ 5-7)
- Remove the air cleaner box. (☞ 5-15)
- Disconnect the ignition switch coupler ①.

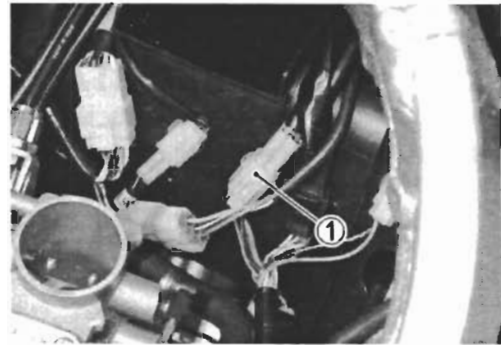

- Remove the ignition switch mounting bolts with the special tools.

**TOOL** 09930-11920: Torx bit JT40H  
09930-11940: Bit holder

#### CAUTION

When reusing the ignition switch bolt, clean thread and apply the **THREAD LOCK SUPER "1322"** or **THREAD LOCK "1342"**.



- ☞ **1342** 99000-32050: **THREAD LOCK "1342"** (USA)
- ☞ **1322** 99000-32110: **THREAD LOCK SUPER "1322"** (Others)

## INSPECTION

Inspect each switch for continuity with a tester. If any abnormality is found, replace the respective switch assemblies with new ones.

### IGNITION SWITCH

Color Position	R	O	O/Y	Br
ON	○	○	○	○
OFF				
LOCK				
P	○			○

### DIMMER SWITCH

Color Position	W	Y	Y/W
HI (≡▷)		○	○
LO (≡▷)	○		○

### TURN SIGNAL LIGHT SWITCH

Color Position	Lg	Lbl	B
L		○	○
PUSH			
R	○	○	

### PASSING LIGHT SWITCH

Color Position	O/R	Y
•		
PUSH	○	○

### ENGINE STOP SWITCH

Color Position	O/B	O/W
OFF (⊗)		
RUN (⊙)	○	○

### STARTER BUTTON

Color Position	O/W	Y/G
•		
PUSH	○	○

### HORN BUTTON

Color Position	B/BI	B/W
•		
PUSH	○	○

### HAZARD

Color Position	Lg	Lbl	B
ON	○	○	○
OFF			

### FRONT BRAKE SWITCH

Color Position	B/R	B/BI
OFF		
ON	○	○

### REAR BRAKE SWITCH

Color Position	O	W/B
OFF		
ON	○	○

### CLUTCH SWITCH

Color Position	B/Y	B/Y
OFF		
ON	○	○

### OIL PRESSURE SWITCH

Color Position	G/Y	Ground
ON (engine is stopped)	○	○
OFF (engine is running)		

#### NOTE:

Before inspecting the oil pressure switch, check the engine oil level. (↗ 2-13)

#### WIRE COLOR

B	: Black	B/BI	: Black with Blue tracer
Br	: Brown	B/W	: Black with White tracer
Lbl	: Light blue	B/Y	: Black with Yellow tracer
Lg	: Light green	B/R	: Black with Red tracer
O	: Orange	G/Y	: Green with Yellow tracer
R	: Red	O/B	: Orange with Black tracer
Y	: Yellow	O/R	: Orange with Red tracer
W	: White	O/W	: Orange with White tracer
		O/Y	: Orange with Yellow tracer
		W/B	: White with Black tracer
		Y/G	: Yellow with Green tracer
		Y/W	: Yellow with White tracer

## BATTERY SPECIFICATIONS

Type designation	YTX12 – BS
Capacity	12 V, 36.0 kC (10 Ah)/10 HR

- |                        |                                |
|------------------------|--------------------------------|
| ① Upper cover breather | ⑤ Terminal                     |
| ② Cathode plates       | ⑥ Safety valve                 |
| ③ Stopper              | ⑦ Anode plates                 |
| ④ Filter               | ⑧ Separator (Fiberglass plate) |

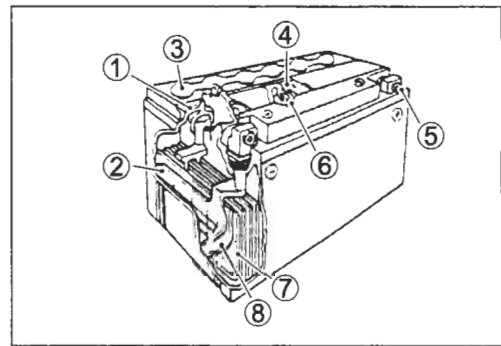

## INITIAL CHARGING

### Filling electrolyte

- Remove the aluminum tape ① sealing the battery electrolyte filler holes (A).

#### NOTE:

When filling electrolyte, the battery must be removed from the vehicle and must be put on the level ground.

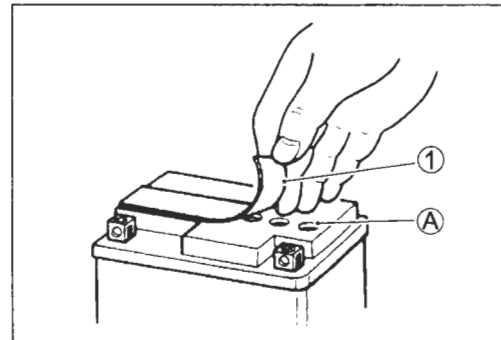

- Remove the caps ②.

#### NOTE:

- After filling the electrolyte completely, use the removed cap ② as the sealed caps of battery-filler holes.
- Do not remove or pierce the sealed areas ③ of the electrolyte container.

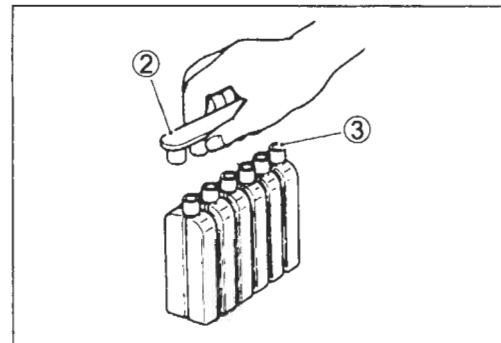

- Insert the nozzles of the electrolyte container ④ into the battery's electrolyte filler holes, holding the container firmly so that it does not fall. Take precaution not to allow any of the fluid to spill.

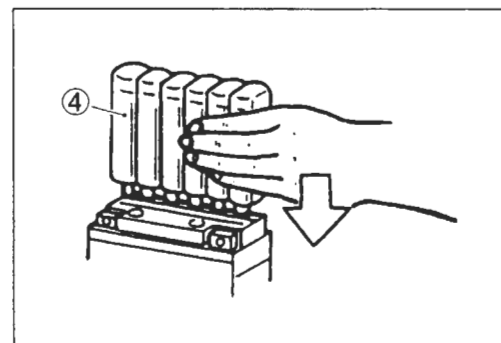

- Make sure air bubbles ⑤ are coming up each electrolyte container, and leave in this position for about more than 20 minutes.

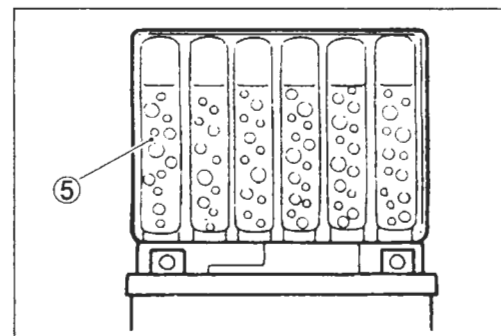

**NOTE:**

If no air bubbles are coming up from a filler port, tap the bottom of the electrolyte container two or three times.

Never remove the container from the battery.

- After confirming that the electrolyte has entered the battery completely, remove the electrolyte containers from the battery. Wait for about 20 minutes.

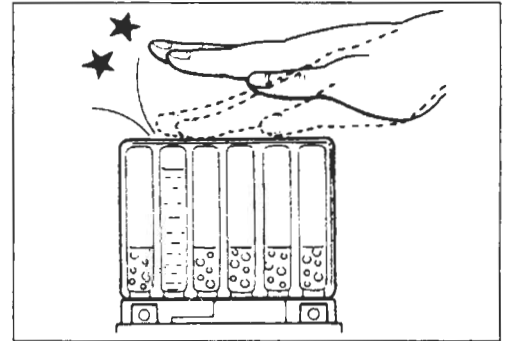

- Insert the caps ⑥ into the filler holes, pressing in firmly so that the top of the caps do not protrude above the upper surface of the battery's top cover.

**CAUTION**

- \* Never use anything except the specified battery.
- \* Once the caps have been installed to the battery, do not remove the caps.
- \* Do not tap the caps with a tool such as hammer when installing them.

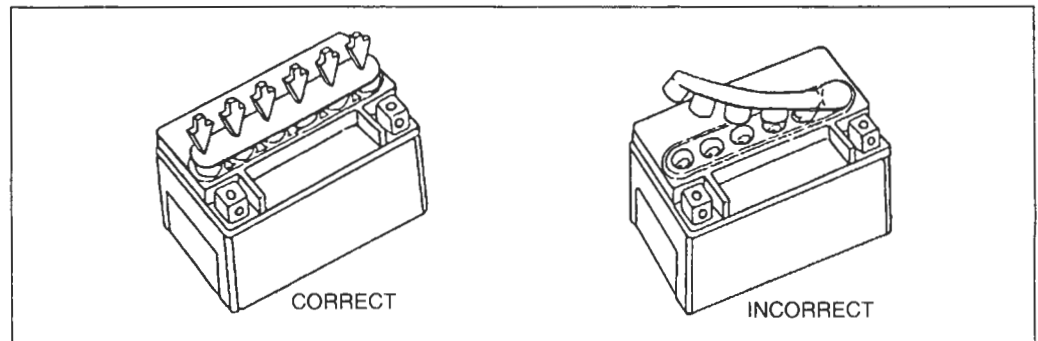
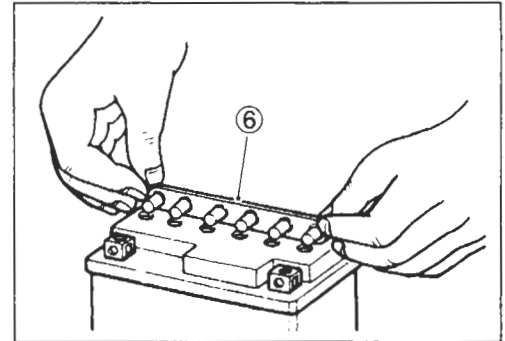

For initial charging, use the charger specially designed for MF battery.

**CAUTION**

- \* For charging the battery, make sure to use the charger specially designed for MF battery. Otherwise, the battery may be overcharged resulting in shortened service life.
- \* Do not remove the cap during charging.
- \* Position the battery with the cap facing upward during charging.

## SERVICING

Visually inspect the surface of the battery container. If any signs of cracking or electrolyte leakage from the sides of the battery have occurred, replace the battery with a new one. If the battery terminals are found to be coated with rust or an acidic white powdery substance, clean the battery terminals with sandpaper.

## RECHARGING OPERATION

- Using the multi circuit tester, check the battery voltage. If the voltage reading is less than the 12.0 V (DC), recharge the battery with a battery charger.

- Ⓐ Charging period
- Ⓑ Stop charging

### CAUTION

- When recharging the battery, remove the battery from the motorcycle.
- Do not remove the caps on the battery top while recharging.

Recharging time: 1.4 A for 5 to 10 hours or 6 A for one hour

### CAUTION

Be careful not to permit the charging current to exceed 6 A at any time.

- After recharging, wait for more than 30 minutes and check the battery voltage with a multi circuit tester.
- If the battery voltage is less than the 12.5 V, recharge the battery again.
- If battery voltage is still less than 12.5 V, after recharging, replace the battery with a new one.
- When the motorcycle is not used for a long period, check the battery every 1 month to prevent the battery discharge.

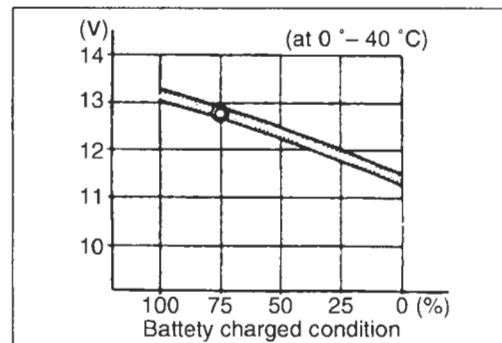
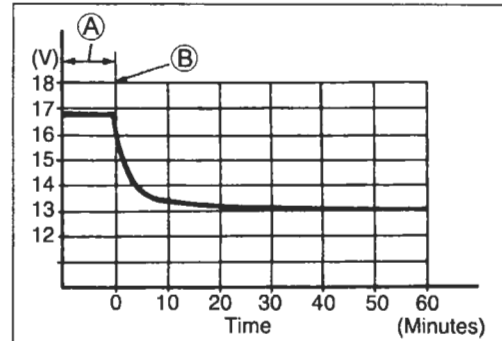

# SERVICING INFORMATION

## CONTENTS

<b>TROUBLESHOOTING</b> .....	9- 2
<b>MALFUNCTION CODE AND DEFECTIVE CONDITION</b> .....	9- 2
<b>ENGINE</b> .....	9- 4
<b>RADIATOR (COOLING SYSTEM)</b> .....	9-10
<b>CHASSIS</b> .....	9-11
<b>BRAKES</b> .....	9-12
<b>ELECTRICAL</b> .....	9-13
<b>BATTERY</b> .....	9-15
<b>WIRE HARNESS, CABLE AND HOSE ROUTING</b> .....	9-16
<b>WIRE HARNESS ROUTING</b> .....	9-16
<b>HEATED OXYGEN SENSOR (HO2S) WIRE ROUTING</b> <b>(FOR E-02, 19)</b> .....	9-18
<b>ENGINE ELECTRICAL PARTS SET-UP</b> .....	9-19
<b>SPEED SENSOR LEAD WIRE ROUTING</b> .....	9-20
<b>THROTTLE CABLE ROUTING</b> .....	9-21
<b>CLUTCH CABLE ROUTING</b> .....	9-22
<b>THROTTLE BODY INSTALLATION/HOSE ROUTING</b> .....	9-23
<b>COOLING SYSTEM HOSE ROUTING</b> .....	9-24
<b>FRONT BRAKE HOSE ROUTING</b> .....	9-26
<b>REAR BRAKE HOSE ROUTING</b> .....	9-27
<b>FUEL TANK DRAIN HOSE ROUTING</b> .....	9-28
<b>FUEL TANK INSTALLATION</b> .....	9-29
<b>PAIR (AIR SUPPLY) SYSTEM HOSE ROUTING</b> .....	9-30
<b>SEAT LOCK CABLE ROUTING</b> .....	9-31
<b>HEAD LAMP SET-UP</b> .....	9-31
<b>ABSORBER HOSE ROUTING</b> .....	9-32
<b>BATTERY CUSHION INSTALLATION</b> .....	9-32
<b>SIDE-STAND SET-UP</b> .....	9-33
<b>BRAKE PEDAL/FOOTREST SET-UP</b> .....	9-33
<b>ENGINE CAP INSTALLATION</b> .....	9-34
<b>FOOTREST SET-UP</b> .....	9-35
<b>HANDLEBAR BALANCER INSTALLATION</b> .....	9-35
<b>SPECIAL TOOLS</b> .....	9-36
<b>TIGHTENING TORQUE</b> .....	9-40
<b>ENGINE</b> .....	9-40
<b>FI SYSTEM PARTS</b> .....	9-41
<b>CHASSIS</b> .....	9-42
<b>TIGHTENING TORQUE CHART</b> .....	9-43
<b>SERVICE DATA</b> .....	9-44



## TROUBLESHOOTING

### MALFUNCTION CODE AND DEFECTIVE CONDITION

MALFUNCTION CODE	DETECTED ITEM	DETECTED FAILURE CONDITION
		CHECK FOR
C00	NO FAULT	
C12	Crankshaft position sensor	The signal does not reach ECM for 3 sec. and more, after receiving the IAP signal.
		The crankshaft position sensor wiring and mechanical parts. (Crankshaft position sensor, lead wire/coupler connection)
C13	Intake air pressure sensor	The sensor should produce following voltage. $0.1 \text{ V} \leq \text{sensor voltage} \leq 4.8 \text{ V}$ Without the above range for 4 sec. and more, C13 is indicated.
		Intake air pressure sensor, lead wire/coupler connection.
C14	Throttle position sensor	The sensor should produce following voltage. $0.1 \text{ V} \leq \text{sensor voltage} < 4.8 \text{ V}$ Without the above range for 4 sec. and more, C14 is indicated.
		Throttle position sensor, lead wire/coupler connection.
C15	Engine coolant temperature sensor	The sensor voltage should be the following. $0.1 \text{ V} \leq \text{sensor voltage} < 4.6 \text{ V}$ Without the above range for 4 sec. and more, C15 is indicated.
		Engine coolant temperature sensor, lead wire/coupler connection.
C21	Intake air temperature sensor	The sensor voltage should be the following. $0.1 \text{ V} \leq \text{sensor voltage} < 4.6 \text{ V}$ Without the above range for 4 sec. and more, C21 is indicated.
		Intake air temperature sensor, lead wire/coupler connection.
C23	Tip over sensor	The sensor voltage should be the following for 2 sec. and more after ignition switch turns ON. $0.2 \text{ V} \leq \text{sensor voltage} \leq 4.6 \text{ V}$ Without the above value for 2 sec. and more, C23 is indicated.
		Tip over sensor, lead wire/coupler connection.
C24/C25	Ignition signal #1/#2	Crankshaft position sensor (pick-up coil) signal is produced, but signal from ignition coil is interrupted continuous by 8 times or more. In this case, the code C24 or C25 is indicated.
		Ignition coil, wiring/coupler connection, power supply from the battery.

MALFUNCTION CODE	DETECTED ITEM	DETECTED FAILURE CONDITION
		CHECK FOR
C28	Secondary throttle valve actuator	When no actuator control signal is supplied from the ECM or communication signal does not reach ECM or operation voltage does not reach STVA motor, C28 is indicated. STVA can not operate. STVA lead wire/coupler.
C29	Secondary throttle position sensor	The sensor should produce following voltage. $0.1 \text{ V} \leq \text{sensor voltage} \leq 4.8 \text{ V}$ Without the above range for 4 sec. and more, C29 is indicated. Secondary throttle position sensor, lead wire/coupler connection.
C31	Gear position signal	It judges from gear position voltage, engine speed and throttle position by ECM, when the gear position voltage is 0.2 V and less. Gear position sensor, wiring/coupler connection. Gearshift cam etc.
C32/C33	Fuel injector #1/#2	When fuel injector voltage gets 1.3 V and less, C32 or C33 is indicated. Injector, wiring/coupler connection, power supply to the injector.
C41	Fuel pump relay	No voltage is applied to the both injectors #1/#2 for 3 sec. after the contact of fuel pump relay is turned ON. Or voltage is applied to the both injectors #1/#2, when the contact of fuel pump is OFF. Fuel pump relay, connecting lead wire, power source to fuel pump relay, fuel injectors.
C42	Ignition switch	Ignition switch signal is not input in ECM. Ignition switch, lead wire/coupler.
C44	Heated oxygen sensor (HO2S) [E-02, 19]	The sensor voltage should be the following and less after warming up condition. (Sensor voltage $\leq 0.4 \text{ V}$ ) Without the above value, C44 is indicated. Heater operation voltage does not reach in the oxygen heater circuit, C44 in indicated. The Heater can not operate. HO2S lead wire/coupler connection. Battery voltage supply to the HO2S.
C49	PAIR control solenoid valve	PAIR control solenoid valve voltage is not input in ECM. PAIR control solenoid valve, lead wire/coupler.

## ENGINE

### ENGINE WILL NOT START OR IS HARD TO START

#### Symptom, possible causes and remedy

- |  |                         |
|--|-------------------------|
| 1) Compression too low                         |                         |
| • Valve clearance out of adjustment.           | Adjust.                 |
| • Worn valve guides or poor seating of valves. | Repair or replace.      |
| • Mistimed valves.                             | Adjust.                 |
| • Excessively worn piston rings.               | Replace.                |
| • Worn-down cylinder bores.                    | Replace.                |
| • Starter motor cranks too slowly.             | See electrical section. |
| • Poor seating of spark plugs.                 | Retighten.              |
| 2) Plug not sparking                           |                         |
| • Fouled spark plugs.                          | Clean or replace.       |
| • Wet spark plugs.                             | Clean and dry.          |
| • Defective ignition coils.                    | Replace.                |
| • Open or short in high-tension cord.          | Replace.                |
| • Defective CKP sensor.                        | Replace.                |
| • Defective ECM.                               | Replace.                |
| • Open-circuited wiring connections.           | Repair or replace.      |
| 3) No fuel reaching the intake manifold        |                         |
| • Clogged fuel filter or fuel hose.            | Clean or replace.       |
| • Defective fuel pump.                         | Replace.                |
| • Defective fuel pressure regulator.           | Replace.                |
| • Defective fuel injector.                     | Replace.                |
| • Defective fuel pump relay.                   | Replace.                |
| • Defective ECM.                               | Replace.                |
| • Open-circuited wiring connections.           | Check and repair.       |
| 4) Incorrect fuel/air mixture                  |                         |
| • TP sensor out of adjustment.                 | Adjust.                 |
| • Defective fuel pump.                         | Replace.                |
| • Defective fuel pressure regulator.           | Replace.                |
| • Defective TP sensor.                         | Replace.                |
| • Defective CKP sensor.                        | Replace.                |
| • Defective IAP sensor.                        | Replace.                |
| • Defective ECM.                               | Replace.                |
| • Defective ECT sensor.                        | Replace.                |
| • Defective IAT sensor.                        | Replace.                |

**ENGINE IDLES POORLY****Symptom, possible causes and remedy**

- |                                      |                    |
|--------------------------------------|--------------------|
| • Valve clearance out of adjustment. | Adjust.            |
| • Poor seating of valves.            | Replace or repair. |
| • Defective valve guides.            | Replace.           |
| • Worn down camshafts.               | Replace.           |
| • Too wide spark plug gaps.          | Adjust or replace. |
| • Defective ignition coils.          | Replace.           |
| • Defective CKP sensor.              | Replace.           |
| • Defective ECM.                     | Replace.           |
| • Defective TP sensor.               | Replace.           |
| • Defective fuel pump.               | Replace.           |
| • Imbalanced throttle valve or STV.  | Adjust.            |
| • Damaged or cracked vacuum hose.    | Replace.           |

**ENGINE STALLS OFTEN****Symptom, possible causes and remedy**

- |   |                      |
|---|----------------------|
| 1) Incorrect fuel/air mixture                     |                      |
| • Defective IAP sensor or circuit.                | Repair or replace.   |
| • Clogged fuel filter.                            | Clean or replace.    |
| • Defective fuel pump.                            | Replace.             |
| • Defective fuel pressure regulator.              | Replace.             |
| • Defective ECT sensor.                           | Replace.             |
| • Defective thermostat.                           | Replace.             |
| • Defective IAT sensor.                           | Replace.             |
| • Damaged or cracked vacuum hose.                 | Replace.             |
| 2) Fuel injector improperly operating             |                      |
| • Defective fuel injectors.                       | Replace.             |
| • No injection signal from ECM.                   | Repair or replace.   |
| • Open or short circuited wiring connection.      | Repair or replace.   |
| • Defective battery or low battery voltage.       | Replace or recharge. |
| 3) Control circuit or sensor improperly operating |                      |
| • Defective ECM.                                  | Replace.             |
| • Defective fuel pressure regulator.              | Replace.             |
| • Defective TP sensor.                            | Replace.             |
| • Defective IAT sensor.                           | Replace.             |
| • Defective CKP sensor.                           | Replace.             |
| • Defective ECT sensor.                           | Replace.             |
| • Defective fuel pump relay.                      | Replace.             |
| 4) Engine internal parts improperly operating     |                      |
| • Fouled spark plugs.                             | Clean.               |
| • Defective CKP sensor or ECM.                    | Replace.             |
| • Clogged fuel hose.                              | Clean.               |
| • Valve clearance out of adjustment.              | Adjust.              |

**NOISY ENGINE****Symptom, possible causes and remedy**

- |  |                                  |
|--|----------------------------------|
| 1) Excessive valve chatter                   |                                  |
| • Too large valve clearance.                 | Adjust.                          |
| • Weakened or broken valve springs.          | Replace.                         |
| • Worn tappet or cam surface.                | Replace.                         |
| • Worn and burnt camshaft journal.           | Replace.                         |
| 2) Noise seems to come from piston           |                                  |
| • Worn down pistons or cylinders.            | Replace.                         |
| • Combustion chambers fouled with carbon.    | Clean.                           |
| • Worn piston pins or piston pin bore.       | Replace.                         |
| • Worn piston rings or ring grooves.         | Replace.                         |
| 3) Noise seems to come from cam chain        |                                  |
| • Stretched chain.                           | Replace.                         |
| • Worn sprockets.                            | Replace.                         |
| • Tension adjuster not working.              | Repair or replace.               |
| 4) Noise seems to come from clutch           |                                  |
| • Worn splines of countershaft or hub.       | Replace.                         |
| • Worn teeth of clutch plates.               | Replace.                         |
| • Distorted clutch plates, driven and drive. | Replace.                         |
| • Worn clutch release bearing.               | Replace.                         |
| • Weakened clutch dampers.                   | Replace the primary driven gear. |
| 5) Noise seems to come from crankshaft       |                                  |
| • Rattling bearings due to wear.             | Replace.                         |
| • Worn and burnt big-end bearings.           | Replace.                         |
| • Worn and burnt journal bearings.           | Replace.                         |
| 6) Noise seems to come from transmission     |                                  |
| • Worn or rubbing gears.                     | Replace.                         |
| • Worn splines.                              | Replace.                         |
| • Worn or rubbing primary gears.             | Replace.                         |
| • Worn bearings.                             | Replace.                         |
| 7) Noise seems to come from water pump       |                                  |
| • Too much play on pump shaft bearing.       | Replace.                         |
| • Worn or damaged impeller shaft.            | Replace.                         |
| • Worn or damaged mechanical seal.           | Replace.                         |
| • Contact between pump case and impeller.    | Replace.                         |

**ENGINE RUNS POORLY IN HIGH SPEED RANGE****Symptom, possible causes and remedy**

- |  |                    |
|--|--------------------|
| 1) Defective engine internal/electrical parts                                      |                    |
| • Weakened valve springs.  | Replace.           |
| • Worn camshafts.  | Replace.           |
| • Valve timing out of adjustment.  | Adjust.            |
| • Too narrow spark plug gaps.  | Adjust.            |
| • Ignition not advanced sufficiently due to poorly working timing advance circuit. | Replace ECM.       |
| • Defective ignition coils.  | Replace.           |
| • Defective CKP sensor.  | Replace.           |
| • Defective ECM.   | Replace.           |
| • Clogged fuel hose, resulting in inadequate fuel supply to injector.              | Clean and prime.   |
| • Defective fuel pump.   | Replace.           |
| • Defective TP sensor.   | Replace.           |
| • Defective STP sensor or STVA.  | Replace.           |
| • Clogged air cleaner element.   | Clean or replace.  |
| 2) Defective air flow system   |                    |
| • Clogged air cleaner element.   | Clean or replace.  |
| • Defective throttle valve.  | Adjust or replace. |
| • Defective secondary throttle valve.  | Adjust or replace. |
| • Sucking air from throttle body joint.  | Repair or replace. |
| • Defective ECM.   | Replace.           |
| • Imbalanced throttle valve synchronization.                                       | Adjust.            |
| 3) Defective control circuit or sensor   |                    |
| • Low fuel pressure.   | Repair or replace. |
| • Defective TP sensor.   | Replace.           |
| • Defective IAT sensor.  | Replace.           |
| • Defective CKP sensor.  | Replace.           |
| • Defective GP switch.   | Replace.           |
| • Defective IAP sensor.  | Replace.           |
| • Defective ECM.   | Replace.           |
| • TP sensor out of adjustment.   | Adjust.            |
| • Defective STP sensor and/or STVA.  | Replace.           |

**ENGINE LACKS POWER****Symptom, possible causes and remedy**

## 1) Defective engine internal/electrical parts

- |   |                       |
|---|-----------------------|
| • Loss of valve clearance.                        | Adjust.               |
| • Weakened valve springs.                         | Replace.              |
| • Valve timing out of adjustment.                 | Adjust.               |
| • Worn piston rings or cylinders.                 | Replace.              |
| • Poor seating of valves.                         | Repair.               |
| • Fouled spark plugs.                             | Clean or replace.     |
| • Incorrect spark plugs.                          | Adjust or replace.    |
| • Clogged injectors.                              | Clean or replace.     |
| • TP sensor out of adjustment.                    | Adjust.               |
| • Clogged air cleaner element.                    | Clean or replace.     |
| • Imbalanced throttle valve synchronization.      | Adjust.               |
| • Sucking air from throttle valve or vacuum hose. | Retighten or replace. |
| • Too much engine oil.                            | Drain out excess oil. |
| • Defective fuel pump or ECM.                     | Replace.              |
| • Defective CKP sensor and ignition coils.        | Replace.              |

**Symptom, possible causes and remedy**

## 2) Defective control circuit or sensor

- |  |                    |
|--|--------------------|
| • Low fuel pressure.                         | Repair or replace. |
| • Defective TP sensor.                       | Replace.           |
| • Defective IAT sensor.                      | Replace.           |
| • Defective CKP sensor.                      | Replace.           |
| • Defective GP switch.                       | Replace.           |
| • Defective IAP sensor.                      | Replace.           |
| • Defective ECM.                             | Replace.           |
| • Imbalanced throttle valve synchronization. | Adjust.            |
| • TP sensor out of adjustment.               | Adjust.            |
| • Defective STP sensor and/or STVA.          | Replace.           |

**ENGINE OVERHEATS****Symptom, possible causes and remedy**

## 1) Defective engine internal parts

- |  |                       |
|--|-----------------------|
| • Heavy carbon deposit on piston crowns.     | Clean.                |
| • Not enough oil in the engine.              | Add oil.              |
| • Defective oil pump or clogged oil circuit. | Replace or clean.     |
| • Sucking air from intake pipes.             | Retighten or replace. |
| • Use incorrect engine oil.                  | Change.               |
| • Defective cooling system.                  | See radiator section. |

**Symptom, possible causes and remedy**

## 2) Lean fuel/air mixture

- |   |                    |
|---|--------------------|
| • Short-circuited IAP sensor/lead wire. | Repair or replace. |
| • Short-circuited IAT sensor/lead wire. | Repair or replace. |
| • Sucking air from intake pipe joint.   | Repair or replace. |
| • Defective fuel injectors.             | Replace.           |
| • Defective ECT sensor.                 | Replace.           |

**Symptom, possible causes and remedy**

## 3) The other factors

- |  |          |
|--|----------|
| • Ignition timing too advanced due to defective timing advance system (ECT sensor, GP switch, CKP sensor and ECM.) | Replace. |
| • Drive chain is too tight.  | Adjust.  |

**DIRTY OR HEAVY EXHAUST SMOKE****Symptom, possible causes and remedy**

- |                                      |   |
|--------------------------------------|---|
| • Too much engine oil in the engine. | Check with inspection window. Drain excess oil. |
| • Worn piston rings or cylinders.    | Replace.  |
| • Worn valve guides.                 | Replace.  |
| • Scored or scuffed cylinder walls.  | Replace.  |
| • Worn valves stems.                 | Replace.  |
| • Defective stem seal.               | Replace.  |
| • Worn oil ring side rails.          | Replace.  |

**SLIPPING CLUTCH****Symptom, possible causes and remedy**

- |   |          |
|---|----------|
| • Weakened clutch springs.                    | Replace. |
| • Worn or distorted pressure plates.          | Replace. |
| • Distorted clutch plates or pressure plates. | Replace. |

**DRAGGING CLUTCH****Symptom, possible causes and remedy**

- |  |          |
|--|----------|
| • Some clutch springs weakened while others are not. | Replace. |
| • Distorted pressure plates or clutch plates.        | Replace. |

**TRANSMISSION WILL NOT SHIFT****Symptom, possible causes and remedy**

- |                              |          |
|------------------------------|----------|
| • Broken gearshift cam.      | Replace. |
| • Distorted gearshift forks. | Replace. |
| • Worn gearshift pawl.       | Replace. |



**TRANSMISSION WILL NOT SHIFT BACK**

**Symptom, possible causes and remedy**

- |  |                    |
|--|--------------------|
| • Broken return spring on shift shaft. | Replace.           |
| • Rubbing or sticky shift shaft.       | Repair or replace. |
| • Distorted or worn gearshift forks.   | Replace.           |

**TRANSMISSION JUMPS OUT OF GEAR**

**Symptom, possible causes and remedy**

- |  |          |
|--|----------|
| • Worn shifting gears on driveshaft or countershaft. | Replace. |
| • Distorted or worn gearshift forks.                 | Replace. |
| • Weakened stopper spring on gearshift stopper.      | Replace. |

**RADIATOR (COOLING SYSTEM)**

**ENGINE OVERHEATS**

**Symptom, possible causes and remedy**

- |   |                    |
|---|--------------------|
| • Not enough engine coolant.                                    | Add coolant.       |
| • Radiator core and oil cooler core clogged with dirt or scale. | Clean.             |
| • Faulty cooling fan.   | Repair or replace. |
| • Defective cooling fan thermo-switch.                          | Replace.           |
| • Clogged water passage.  | Clean.             |
| • Air trapped in the cooling circuit.                           | Bleed out air.     |
| • Defective water pump.   | Replace.           |
| • Use of incorrect engine coolant.                              | Replace.           |
| • Defective thermostat.   | Replace.           |

**ENGINE OVERCOOLS**

**Symptom, possible causes and remedy**

- |  |                            |
|--|----------------------------|
| • Defective cooling fan thermo-switch. | Replace.                   |
| • Extremely cold weather.              | Put on the radiator cover. |
| • Defective thermostat.                | Replace.                   |

## CHASSIS

### HEAVY STEERING

#### Symptom, possible causes and remedy

- Overtightened steering stem nut. Adjust.
- Broken bearing in steering stem. Replace.
- Distorted steering stem. Replace.
- Not enough pressure in tires. Adjust.

### WOBBLY HANDLEBARS

#### Symptom, possible causes and remedy

- Loss of balance between right and left front forks. Adjust.
- Distorted front fork. Repair or replace.
- Distorted front axle or crooked tire. Replace.
- Loose steering stem nut. Adjust.
- Worn or incorrect tire or wrong tire pressure. Adjust or replace.
- Worn bearing/race in steering stem. Replace.

### WOBBLY FRONT WHEEL

#### Symptom, possible causes and remedy

- Distorted wheel rim. Replace.
- Worn front wheel bearings. Replace.
- Defective or incorrect tire. Replace.
- Loose axle or axle pinch bolt. Retighten.
- Incorrect front fork oil level. Adjust.
- Incorrect front wheel weight balance. Adjust.

### FRONT SUSPENSION TOO SOFT

#### Symptom, possible causes and remedy

- Weakened springs. Replace.
- Not enough fork oil. Replenish.
- Wrong viscous fork oil. Replace.
- Improperly set front fork spring adjuster. Adjust.

### FRONT SUSPENSION TOO STIFF

#### Symptom, possible causes and remedy

- Too viscous fork oil. Replace.
- Too much fork oil. Drain excess oil.
- Improperly set front fork spring adjuster. Adjust.
- Bent front axle. Replace.

### NOISY FRONT SUSPENSION

#### Symptom, possible causes and remedy

- Not enough fork oil. Replenish.
- Loose bolts on suspension. Retighten.

### WOBBLY REAR WHEEL

#### Symptom, possible causes and remedy

- Distorted wheel rim. Replace.
- Worn rear wheel bearing or swingarm bearings. Replace.
- Defective or incorrect tire. Replace.
- Worn swingarm and rear suspensions. Replace.
- Loose nuts or bolts on rear suspensions. Retighten.

**REAR SUSPENSION TOO SOFT****Symptom, possible causes and remedy**

- Weakened spring of shock absorber. Replace.
- Leakage of oil from shock absorber. Replace.
- Improperly set rear spring unit adjuster. Adjust.

**REAR SUSPENSION TOO STIFF****Symptom, possible causes and remedy**

- Bent shock absorber shaft. Replace.
- Bent swingarm pivot shaft. Replace.
- Worn swingarm and suspension bearings. Replace.
- Improperly set rear spring unit adjuster. Adjust.

**NOISY REAR SUSPENSION****Symptom, possible causes and remedy**

- Loose nuts or bolts on rear suspension. Retighten.
- Worn swingarm and suspension bearings. Replace.

**BRAKES****INSUFFICIENT BRAKE POWER****Symptom, possible causes and remedy**

- Leakage of brake fluid from hydraulic system. Repair or replace.
- Worn pads. Replace.
- Oil adhesion on friction surface of pads. Clean disc and pads.
- Worn disc. Replace.
- Air in hydraulic system. Bleed air.
- Not enough brake fluid in the reservoir. Replenish.

**BRAKE SQUEAKING****Symptom, possible causes and remedy**

- Carbon adhesion on pad surface. Repair surface with sandpaper.
- Tilted pad. Correct pad fitting or replace.
- Damaged wheel bearing. Replace.
- Loose front wheel axle or rear wheel axle. Tighten to specified torque.
- Worn pads or disc. Replace.
- Foreign material in brake fluid. Replace brake fluid.
- Clogged return port of master cylinder. Disassemble and clean master cylinder.

**EXCESSIVE BRAKE LEVER STROKE****Symptom, possible causes and remedy**

- Air in hydraulic system. Bleed air.
- Insufficient brake fluid. Replenish fluid to specified level; bleed air.
- Improper quality of brake fluid. Replace with correct fluid.

**LEAKAGE OF BRAKE FLUID****Symptom, possible causes and remedy**

- Insufficient tightening of connection joints. Tighten to specified torque.
- Cracked hose. Replace.
- Worn piston and/or cup. Replace piston and/or cup.

**BRAKE DRAGS****Symptom, possible causes and remedy**

- |  |                      |
|--|----------------------|
| • Rusty part.  | Clean and lubricate. |
| • Insufficient brake lever or brake pedal pivot lubrication. | Lubricate.           |

**ELECTRICAL****NO SPARKING OR POOR SPARKING****Symptom, possible causes and remedy**

- |  |                   |
|--|-------------------|
| • Defective ignition coils or spark plug caps. | Replace.          |
| • Defective spark plugs.                       | Replace.          |
| • Defective CKP sensor.                        | Replace.          |
| • Defective ECM.                               | Replace.          |
| • Defective TO sensor.                         | Replace.          |
| • Open-circuited wiring connections.           | Check and repair. |

**SPARK PLUG SOON BECOME FOULED WITH CARBON****Symptom, possible causes and remedy**

- |                              |  |
|------------------------------|--|
| • Mixture too rich.          | Inspect FI system.                       |
| • Idling speed set too high. | Adjust fast idle or throttle stop screw. |
| • Incorrect gasoline.        | Change.                                  |
| • Dirty air cleaner element. | Clean or replace.                        |
| • Too cold spark plugs.      | Replace with hot type plugs.             |

**SPARK PLUG BECOME FOULED TOO SOON****Symptom, possible causes and remedy**

- |   |          |
|---|----------|
| • Worn piston rings.                                  | Replace. |
| • Worn piston or cylinders.                           | Replace. |
| • Excessive clearance of valve stems in valve guides. | Replace. |
| • Worn stem oil seal.                                 | Replace. |

**SPARK PLUG ELECTRODES OVERHEAT OR BURN****Symptom, possible causes and remedy**

- |                          |                               |
|--------------------------|-------------------------------|
| • Too hot spark plugs.   | Replace with cold type plugs. |
| • Overheated the engine. | Tune up.                      |
| • Loose spark plugs.     | Retighten.                    |
| • Too lean mixture.      | Consult FI system.            |

**GENERATOR DOES NOT CHARGE****Symptom, possible causes and remedy**

- |   |                                 |
|---|---------------------------------|
| • Open- or short-circuited lead wires, or loose lead connections. | Repair or replace or retighten. |
| • Short-circuited, grounded or open generator coil.               | Replace.                        |
| • Short-circuited or punctured regulator/rectifier.               | Replace.                        |

**GENERATOR DOES CHARGE, BUT CHARGING RATE IS BELOW THE SPECIFICATION**

**Symptom, possible causes and remedy**

- Lead wires tend to get short- or open-circuited or loosely connected at terminals. Repair or retighten.
- Grounded or open-circuited generator coil. Replace.
- Defective regulator/rectifier. Replace.
- Defective cell plates in the battery. Replace the battery.

**GENERATOR OVERCHARGES**

**Symptom, possible causes and remedy**

- Internal short-circuit in the battery. Replace the battery.
- Damaged or defective resistor element in the regulator/rectifier. Replace.
- Poorly grounded regulator/rectifier. Clean and tighten ground connection.

**UNSTABLE CHARGING**

**Symptom, possible causes and remedy**

- Lead wire insulation frayed due to vibration, resulting in intermittent short-circuiting. Repair or replace.
- Internally short-circuited generator. Replace.
- Defective regulator/rectifier. Replace.

**STARTER BUTTON IS NOT EFFECTIVE**

**Symptom, possible causes and remedy**

- Run down battery. Repair or replace.
- Defective switch contacts. Replace.
- Brushes not seating properly on starter motor commutator. Repair or replace.
- Defective starter relay/starter interlock switch. Replace.
- Defective main fuse. Replace.

## BATTERY

### “SULFATION”, ACIDIC WHITE POWDERY SUBSTANCE OR SPOTS ON SURFACE OF CELL PLATES

#### Symptom, possible causes and remedy

- Cracked battery case. Replace the battery.
- Battery has been left in a run-down condition for a long time. Replace the battery.

### BATTERY RUNS DOWN QUICKLY

#### Symptom, possible causes and remedy

- Trouble in charging system. Check the generator, regulator/rectifier and circuit connections and make necessary adjustments to obtain specified charging operation.
- Cell plates have lost much of their active material as a result of overcharging. Replace and correct the charging system.
- Internal short-circuit in the battery. Replace.
- Too low battery voltage. Recharge fully.
- Too old battery. Replace.

### BATTERY “SULFATION”

#### Symptom, possible causes and remedy

- Incorrect charging rate. Replace.  
(When not in use battery should be checked at least once a month to avoid sulfation.)
- The battery was left unused in a cold climate for too long. Replace if badly sulfated.

# WIRE HARNESS, CABLE AND HOSE ROUTING

## WIRE HARNESS ROUTING

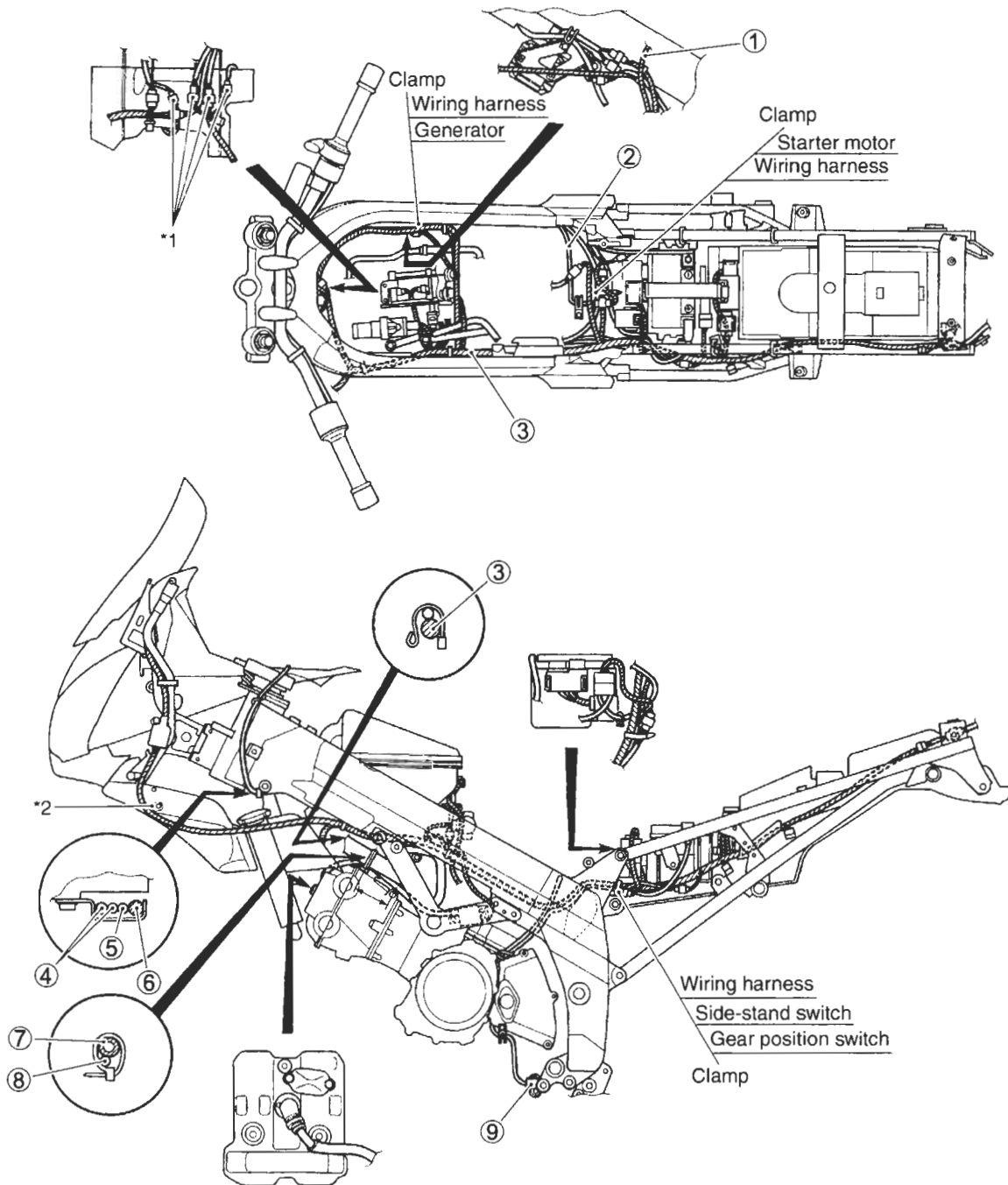

①	IAT sensor lead wire	
②	HO2 sensor lead wire	
③	Wiring harness	*1
④	Throttle cable	
⑤	Clutch cable	
⑥	Handlebar switch left	
⑦	Water hose	*2
⑧	High-tension cord	
⑨	Side-stand switch	

Insert the protruded section each on the handlebar switch lead wire coupler, ignition switch lead wire coupler and cooling fan motor lead wire coupler into the respective holes provided on the frame.

Route the wiring harness under the cowling fastener fitted section.

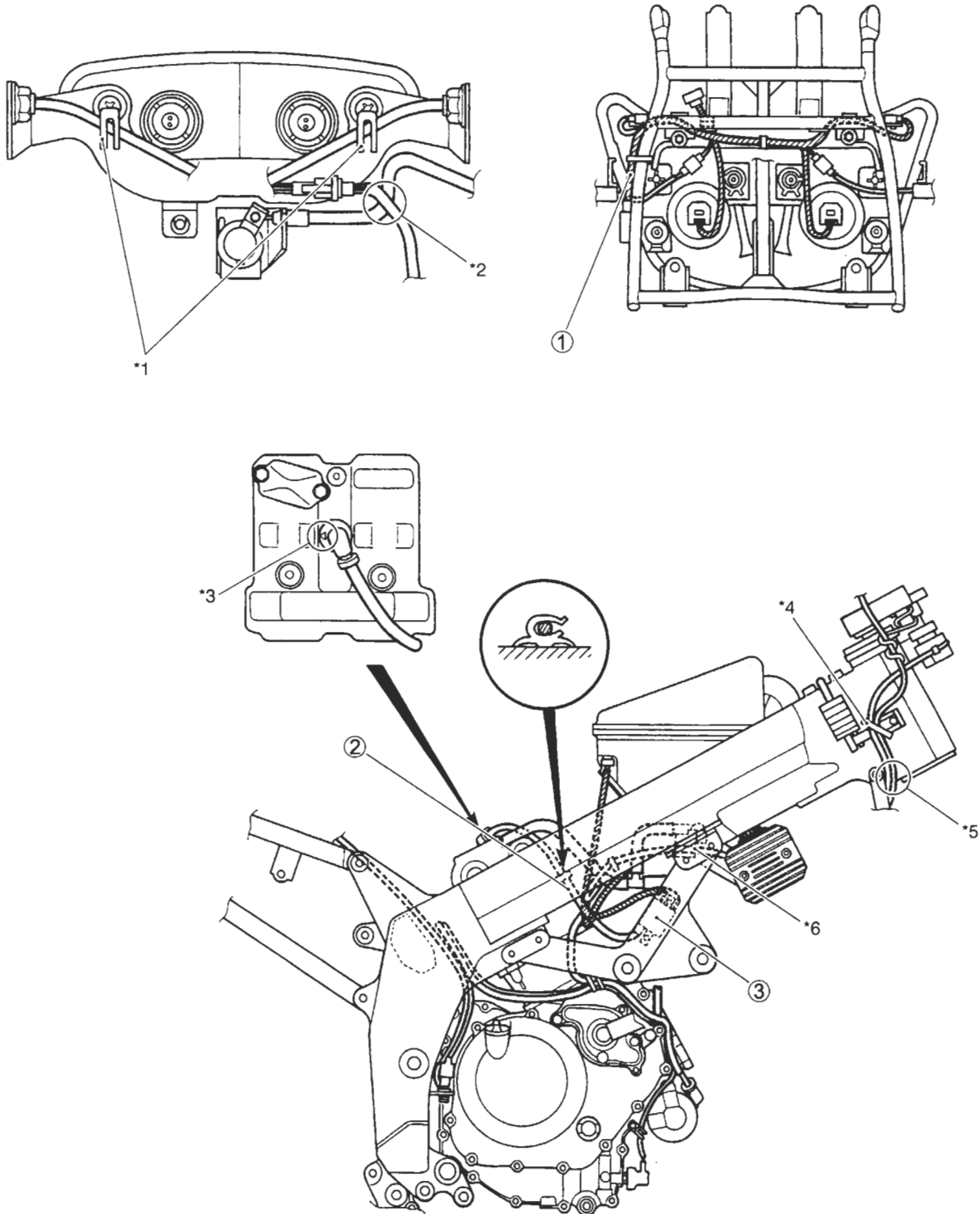

①	Wiring harness No.2	*3	Triangle mark of each spark plug cap must be brought to the exhaust side.
②	Magneto lead wire	*4	Cut the clamp end.
③	Ignition coil No.2	*5	Do not slack the lead wire.
*1	Clamp the turn signal light read wire.	*6	Pass through the PAIR reed valve lead wire between the frame and PAIR control solenoid valve.
*2	Pass through the license light read wire over the seat lock cable.		



## HEATED OXYGEN SENSOR (HO2S) WIRE ROUTING (FOR E-02, 19)

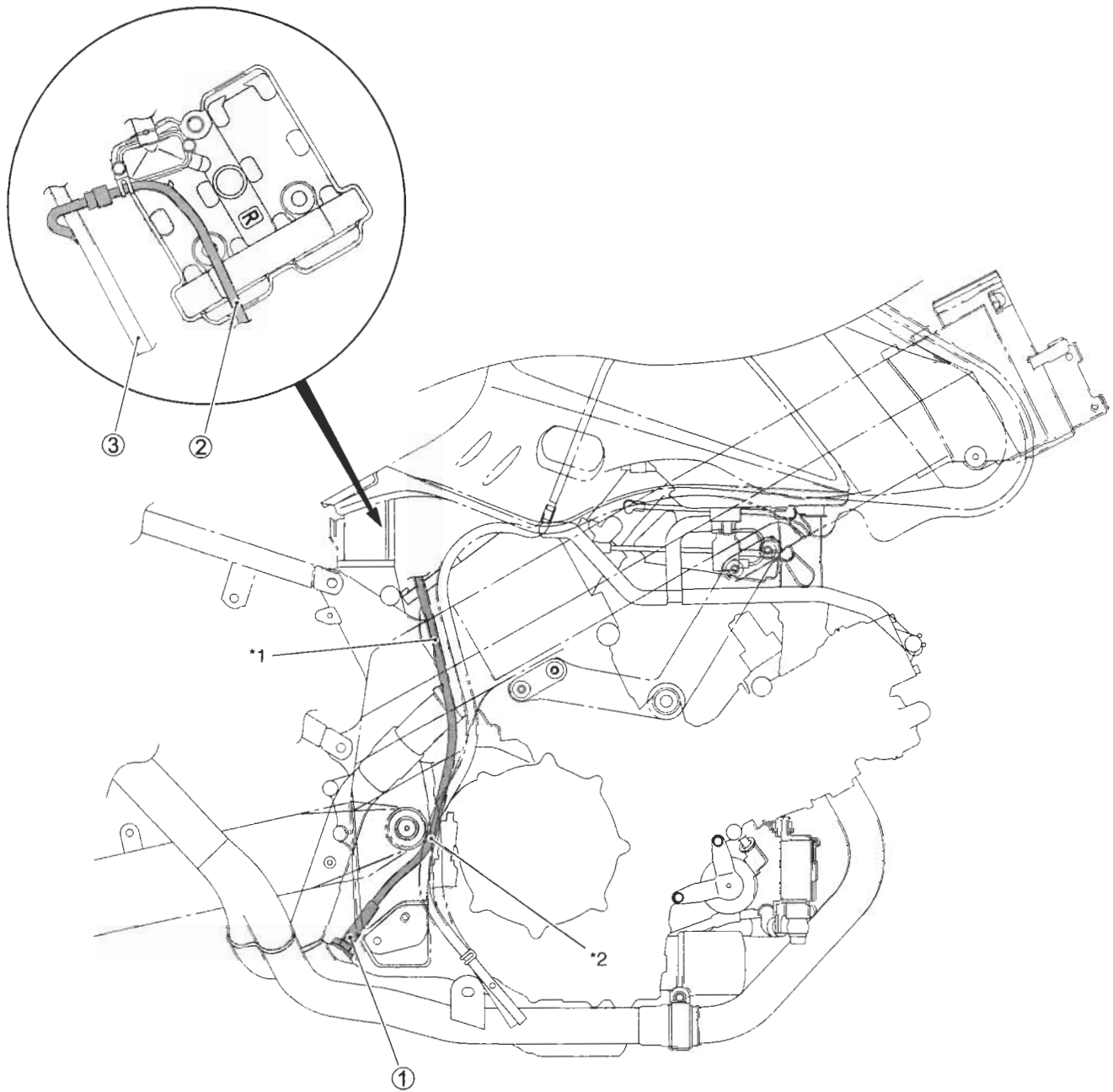

①	HO2 sensor (For E-02, 19)	*1	Route the HO2 sensor lead wire along the fuel tank drain hose.
②	HO2 sensor lead wire	*2	Pass through the HO2 sensor lead wire forward the swingarm.
③	Wiring harness		

# ENGINE ELECTRICAL PARTS SET-UP

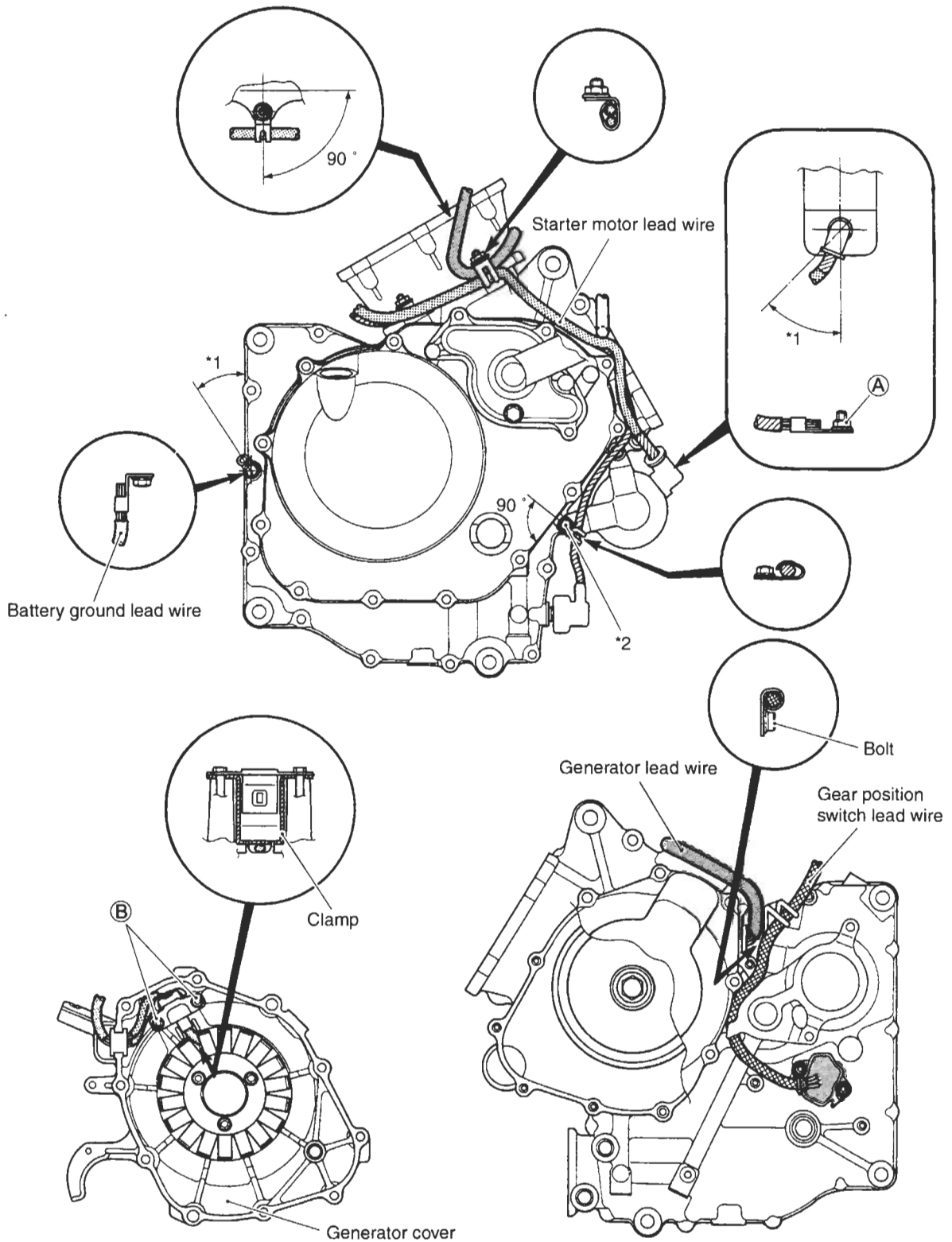

(A)	Starter motor lead wire mounting nut	*1	45 ° and less
(B)	CKP sensor set bolt	*2	First tighten the starter motor lower mounting bolt.

ITEM	N-m	kgf-m	lb-ft
(A)	6.0	0.6	4.3
(B)	6.5	0.65	4.7

## SPEED SENSOR LEAD WIRE ROUTING

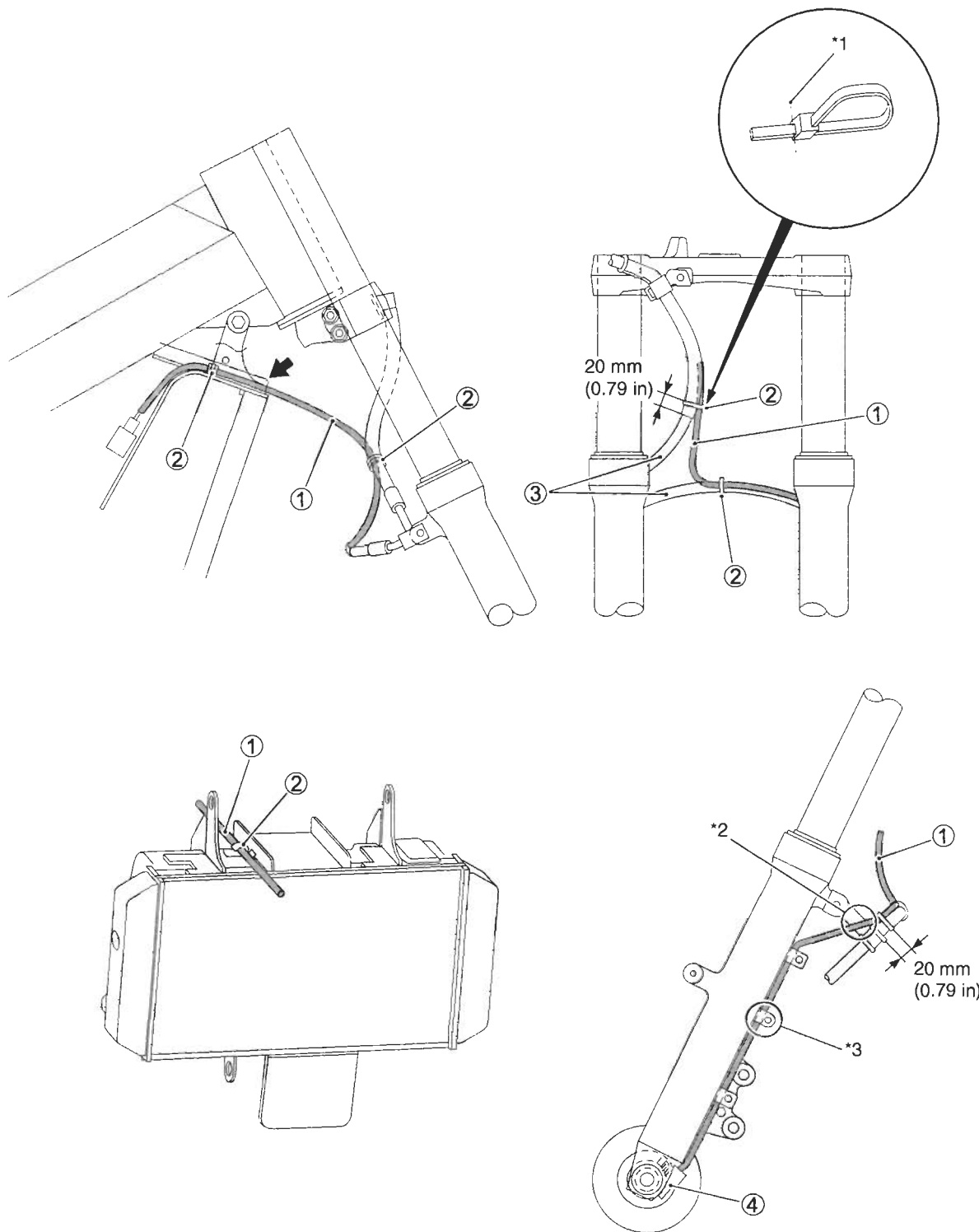

①	Speed sensor lead wire	*1	Cut the clamp end.
②	Clamp	*2	Route speed sensor lead wire to come outside the brake hose guide.
③	Brake hose	*3	Route speed sensor lead wire on inside of front fork outer tube boss.
④	Speed sensor		

# THROTTLE CABLE ROUTING

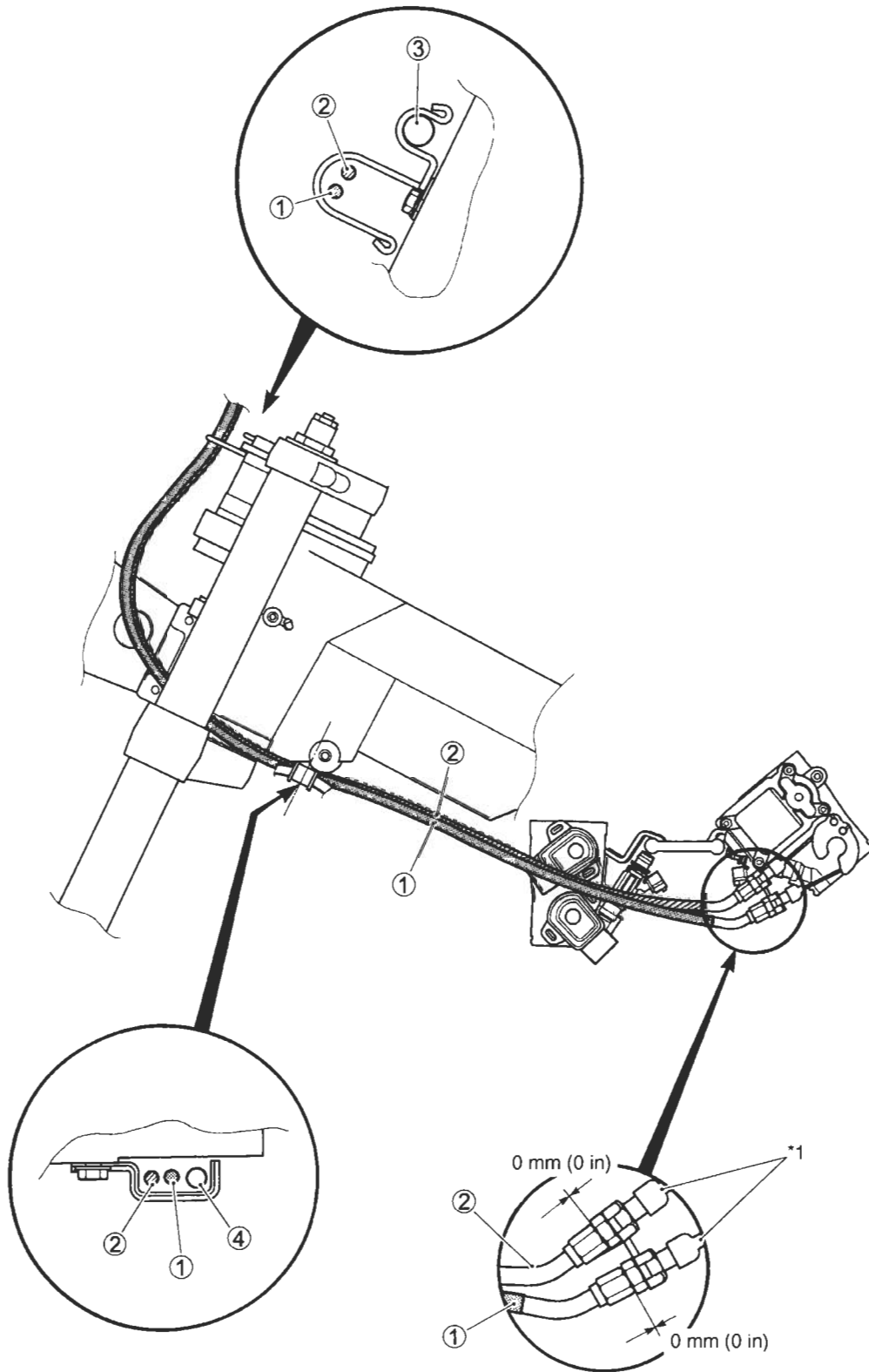

① Throttle cable No.1	④ Wiring harness
② Throttle cable No.2	*1 Fit the cable boots securely.
③ Front brake hose	

# CLUTCH CABLE ROUTING

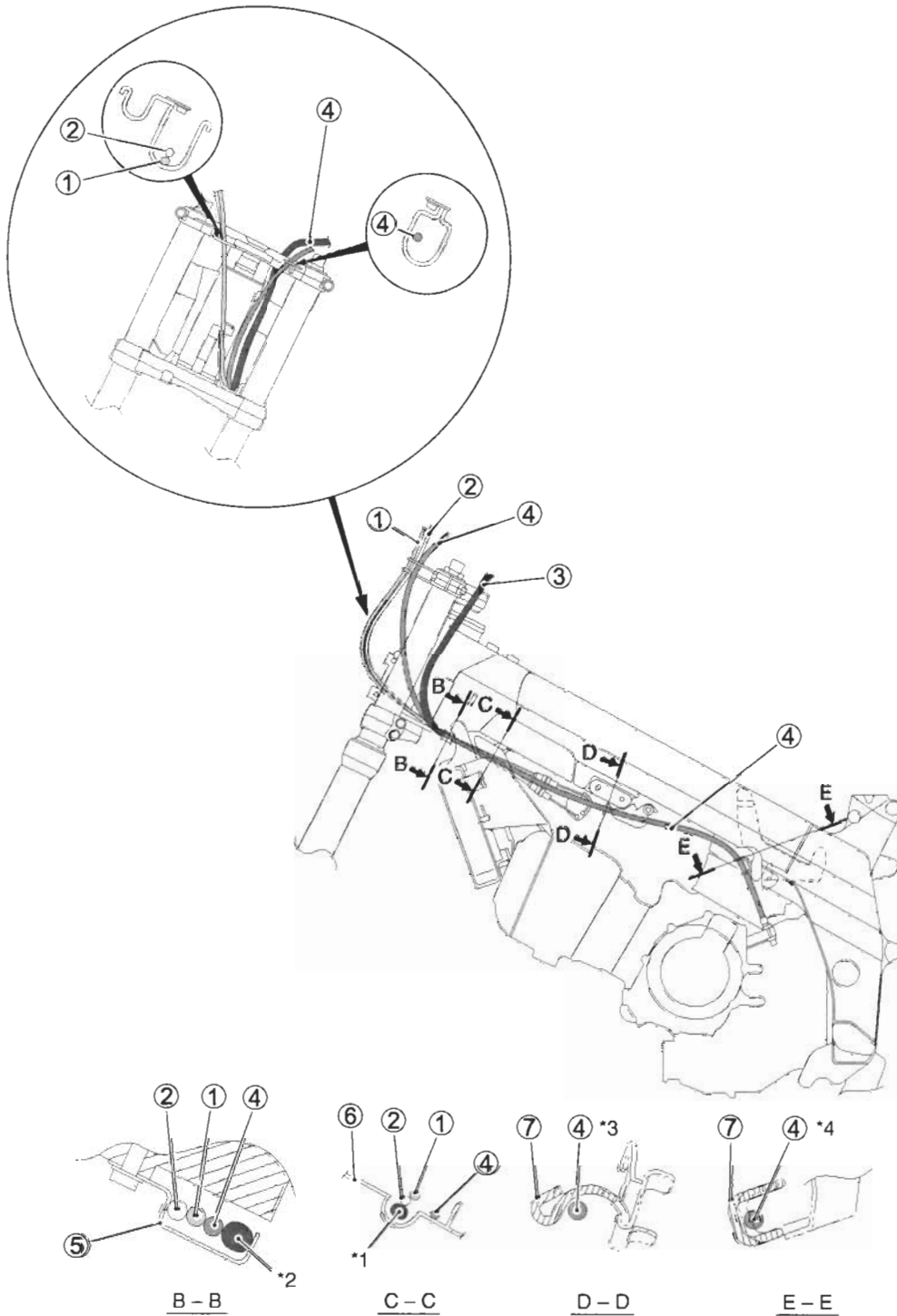

①	Throttle cable (Pull)	⑦	Reserve tank bracket
②	Throttle cable (Return)	*1	Route left handle switch wiring harness in the groove of radiator shroud.
③	Handle switch wiring harness	*2	Route left handle switch wiring harness to come outside throttle and clutch cables.
④	Clutch cable	*3	Route clutch cable inside the guide.
⑤	Throttle cable guide	*4	Route clutch cable inside the guide.
⑥	Radiator shroud		

# THROTTLE BODY INSTALLATION/HOSE ROUTING

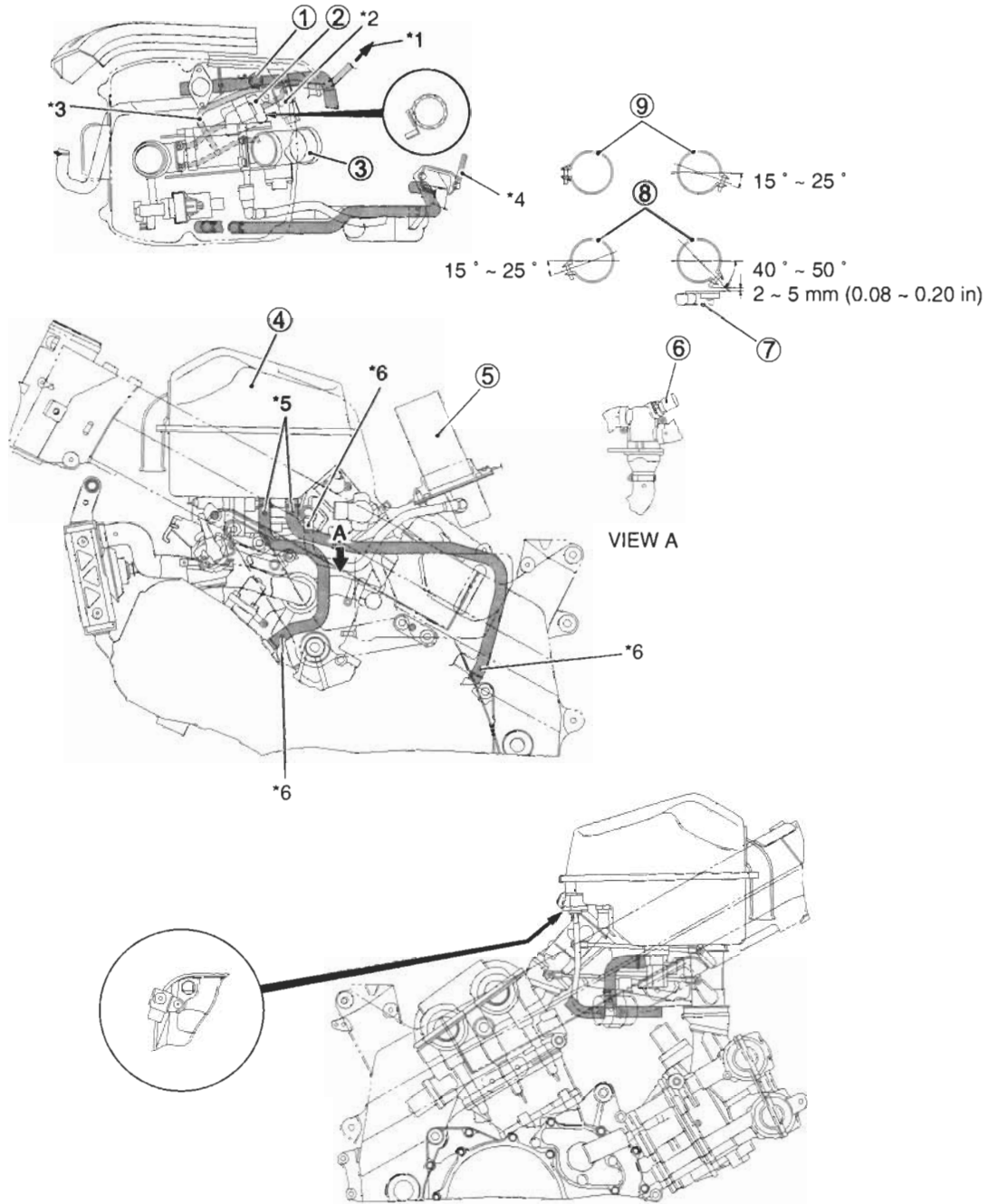

① IAT sensor	⑨ Intake pipe clamp
② Vacuum damper	*1 To canister (For E-33)
③ Throttle body assembly	*2 Pass through the vacuum hose inside the PAIR hose.
④ Air cleaner box	*3 E-33 Only
⑤ Fuel pump assembly	*4 HO2 sensor clamp (For E-02, 19)
⑥ ECT sensor	*5 Matching mark (Yellow)
⑦ TP sensor	*6 Matching mark (White)
⑧ Outlet tube clamp	

## COOLING SYSTEM HOSE ROUTING

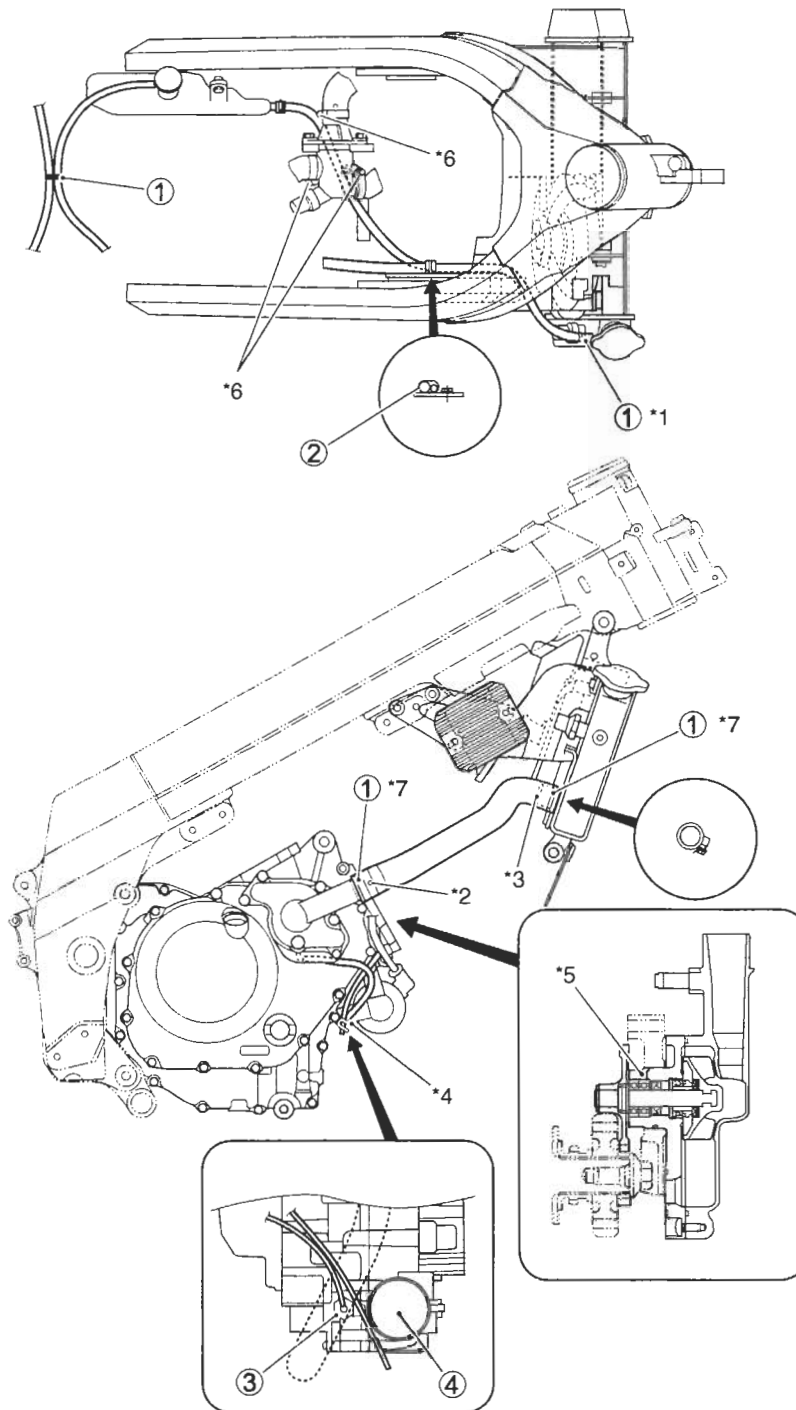

①	Clamp	*3	Matching mark (Yellow)
②	Wiring harness	*4	Clamp the water drain hose and oil pressure switch lead wire.
③	Oil pressure switch	*5	Fill the bearing with engine oil until engine oil comes out from the hole of the bearing housing.
④	Oil filter	*6	Clamp bolt head must face upward.
*1	Clamp end must face downward.	*7	Clamp bolt head must face downward.
*2	Matching mark (White)		

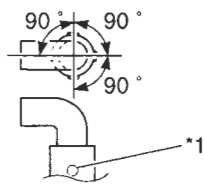
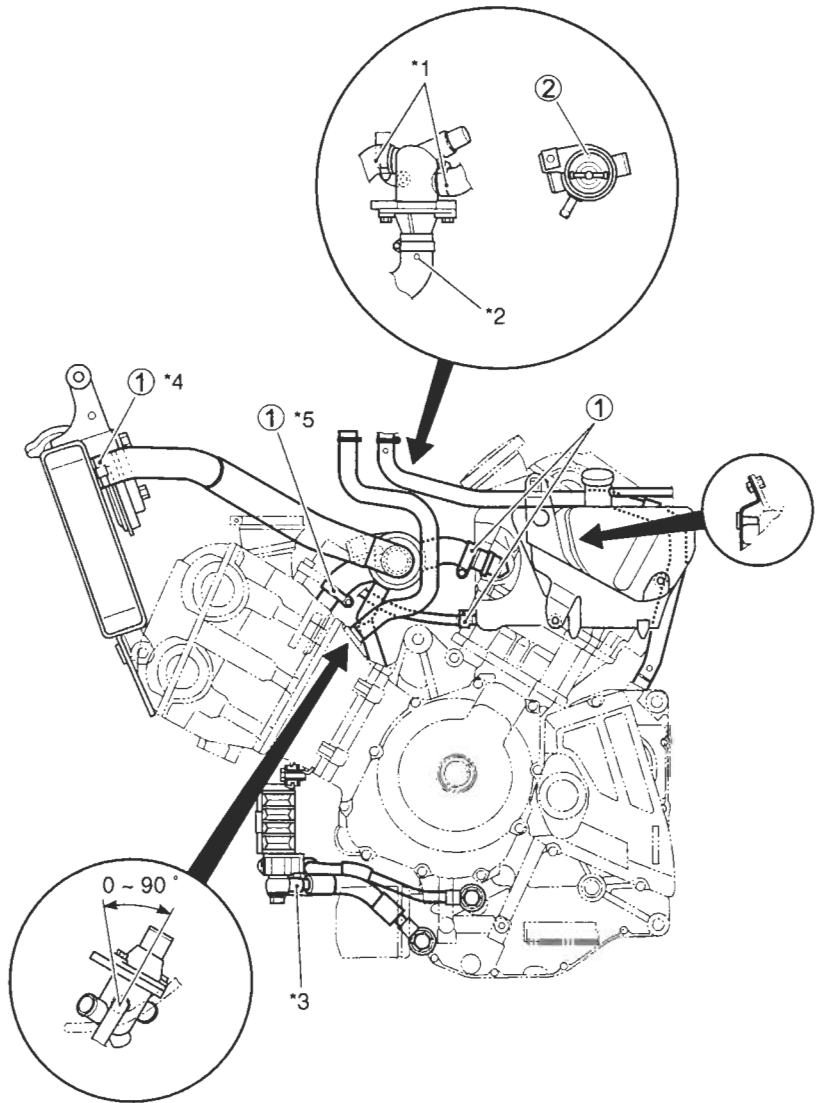
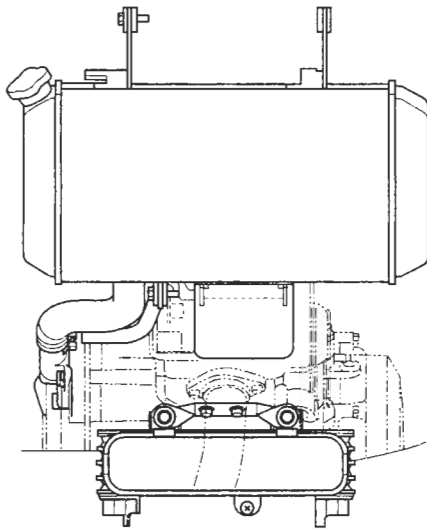
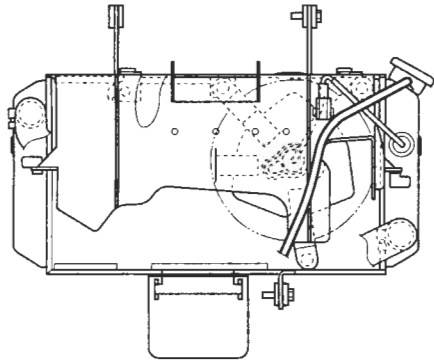

Marking position

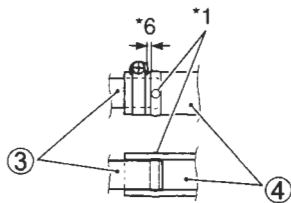

Installation point

①	Clamp	*2	Matching mark (White)
②	Jiggle valve	*3	Marking (Yellow)
③	Union	*4	Clamp bolt head must face downward.
④	Radiator hose	*5	Clamp bolt head must face left side.
*1	Marking	*6	Leave clearance between bulge of union and clamp.



# FRONT BRAKE HOSE ROUTING

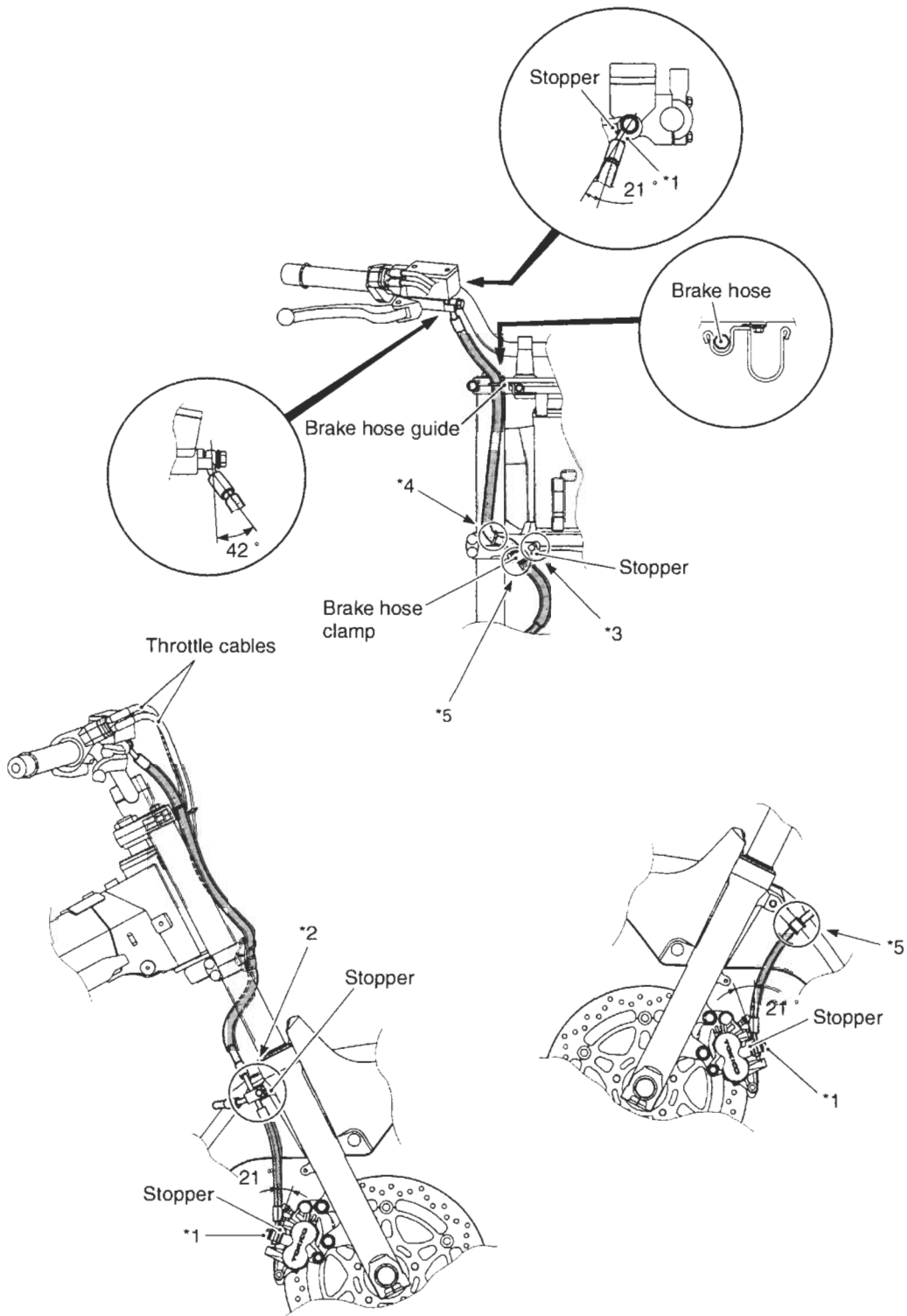

*1	After the brake hose union has contacted the stopper, tighten the union bolt.	*4	Assemble the brake hose firmly.
*2	After positioning the brake hose junction with the stopper, tighten the bolt.	*5	Clamp the brake hose firmly.
*3	After positioning the clamp with the stopper, tighten the clamp bolt.		

## REAR BRAKE HOSE ROUTING

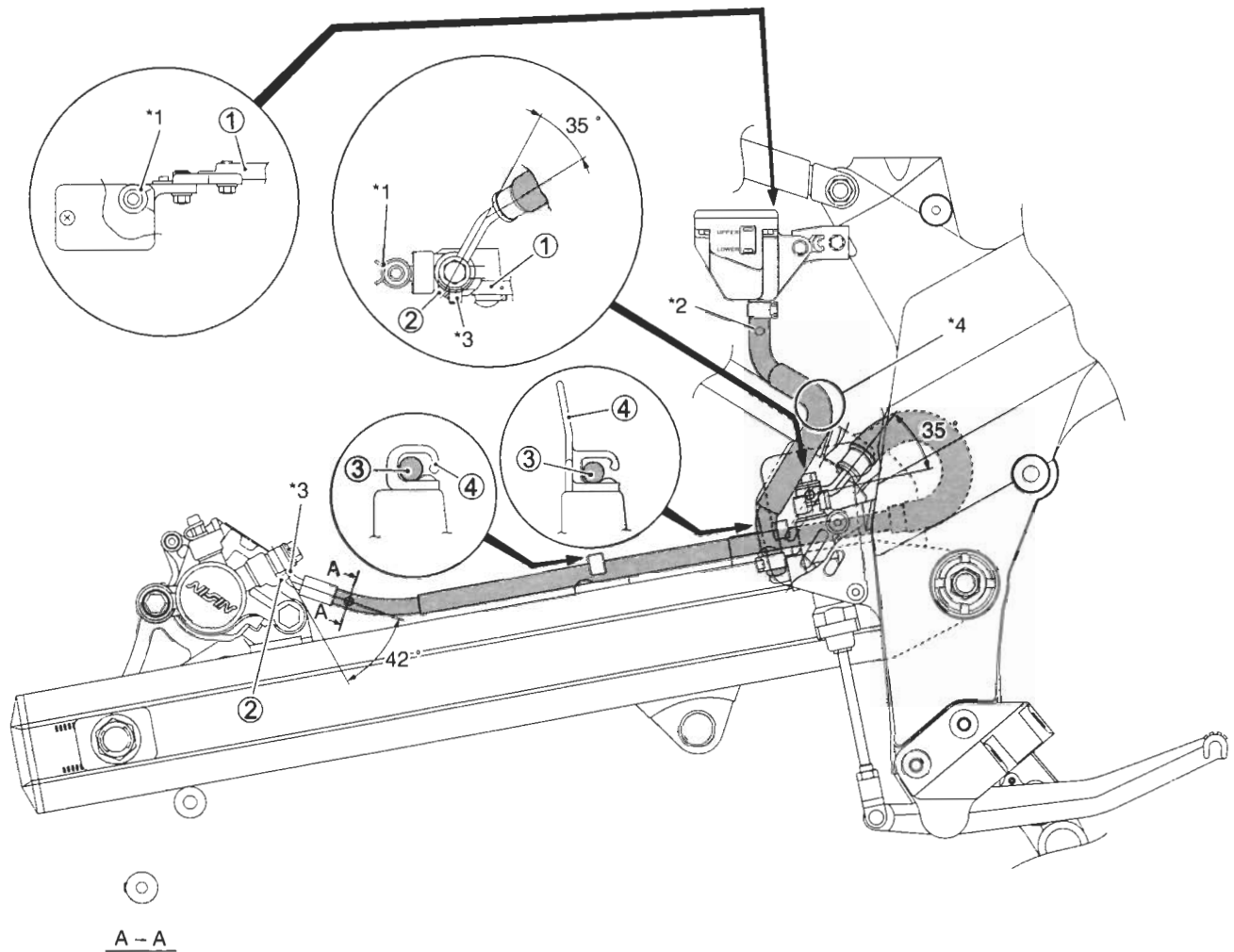

①	Frame	*1	Clamp ends should face forward.
②	Stopper	*2	White paint faces outside.
③	Brake hose	*3	After the brake hose union has contacted the stopper, tighten the union bolt.
④	Brake hose guide	*4	Pass through the brake hose outside the seat rail.

## FUEL TANK DRAIN HOSE ROUTING

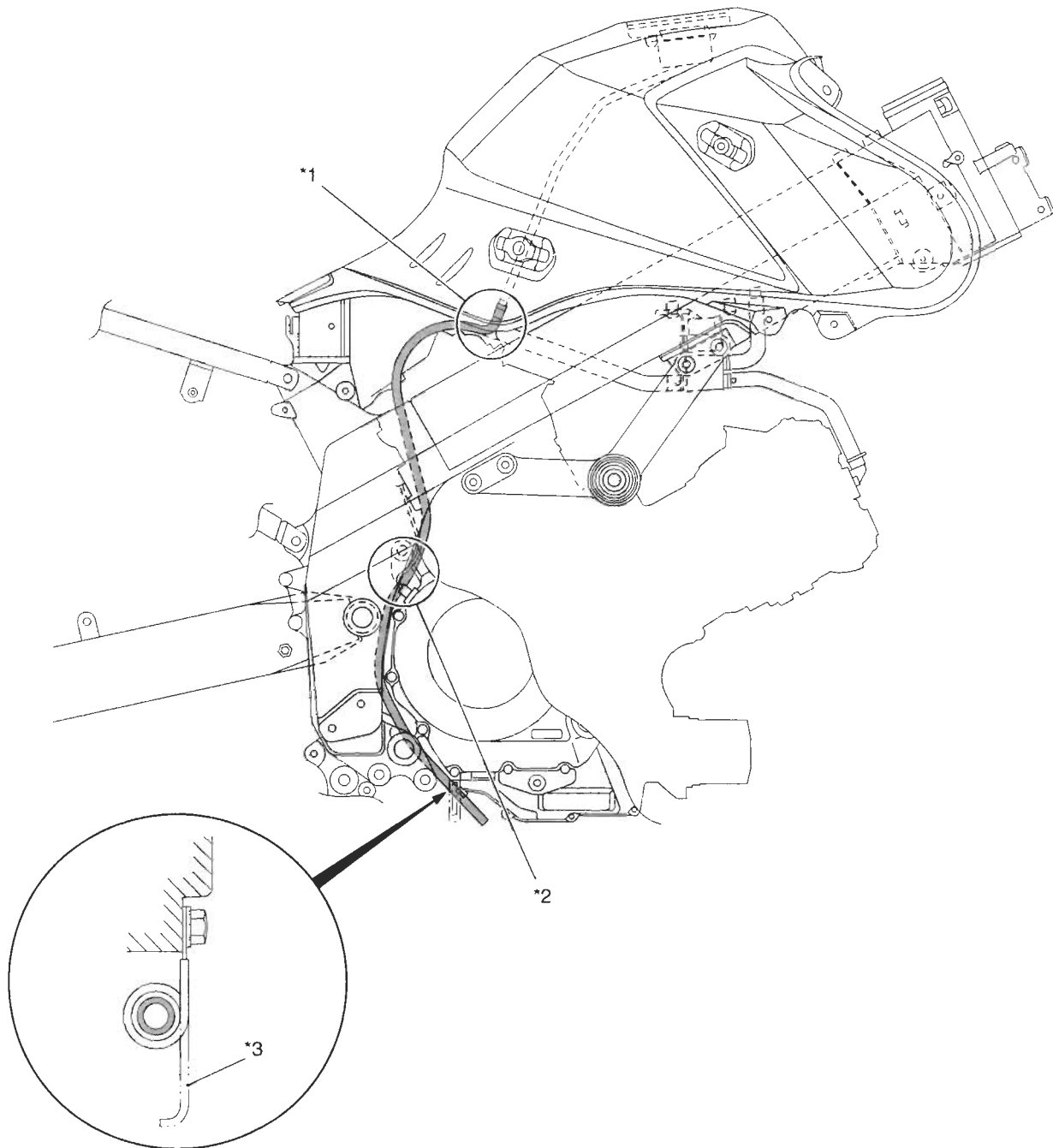

*1	Route fuel tank drain hose so that its curve faces forward.	*3	Make sure to position the clamp in the specified direction.
*2	Route fuel tank drain hose to come inside (left side) gear position sensor wiring harness.		

# FUEL TANK INSTALLATION

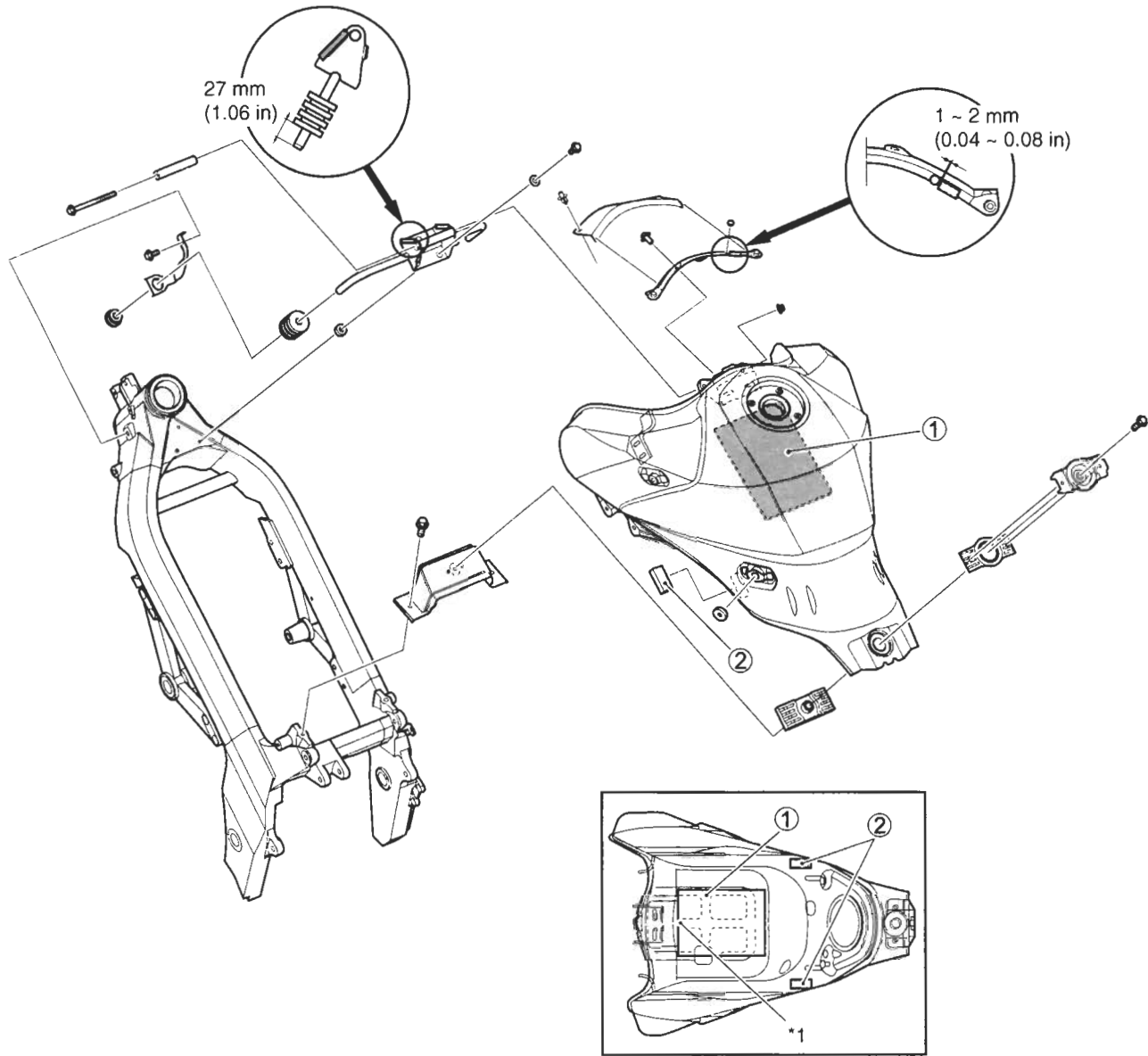

①	Fuel tank center shield	*1 Align the front end of fuel tank center shield with this position.
②	Fuel tank side cushion	

## PAIR (AIR SUPPLY) SYSTEM HOSE ROUTING

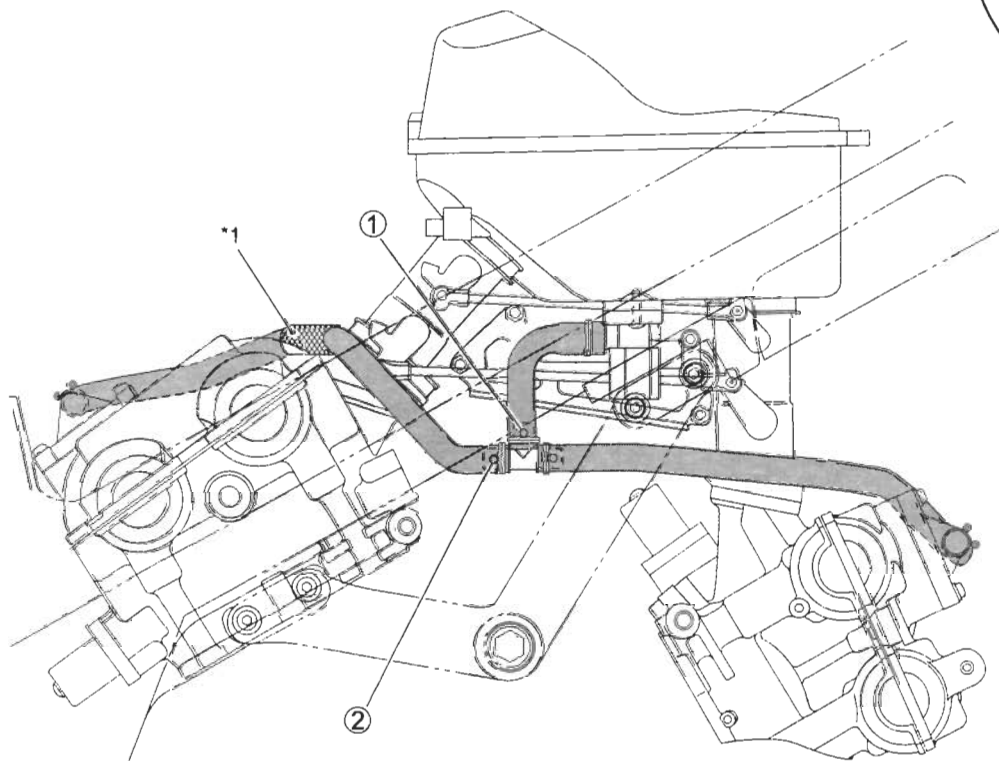
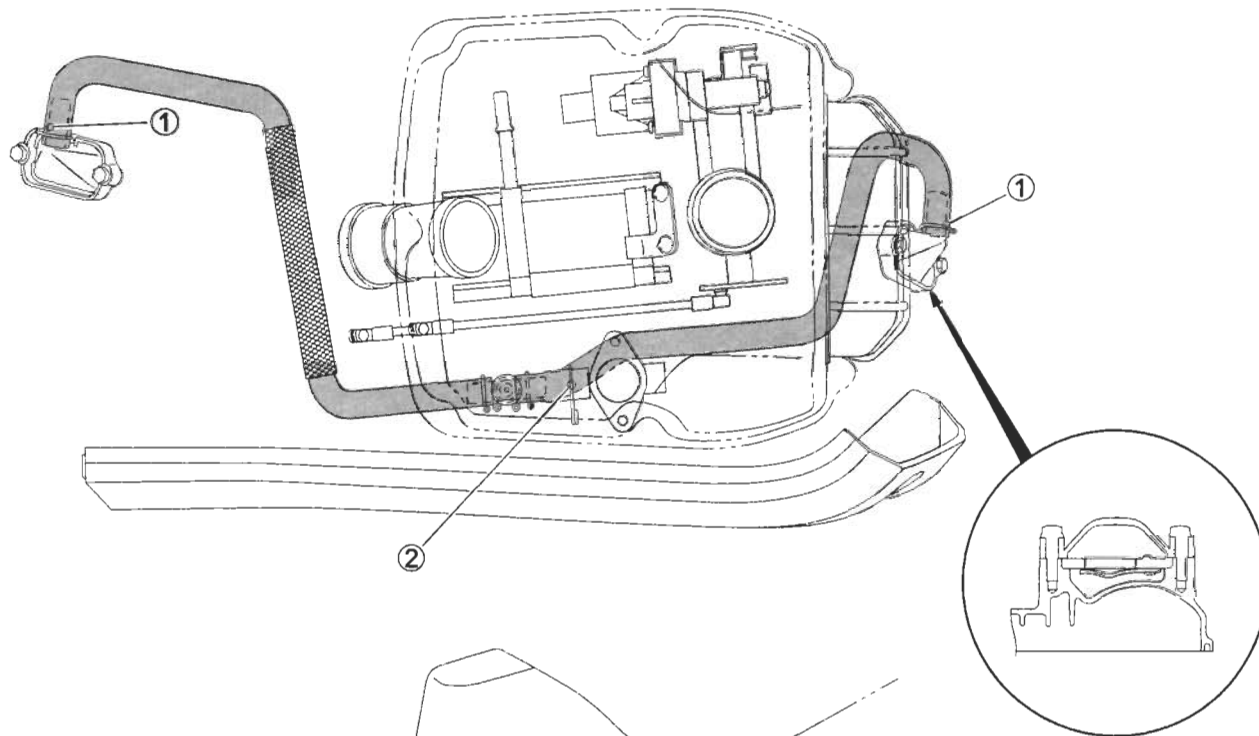

①	Matching mark (White)	*1 Pass the PAIR hose between the cylinder head cover and intake pipe.
②	Matching mark (Yellow)	

## SEAT LOCK CABLE ROUTING

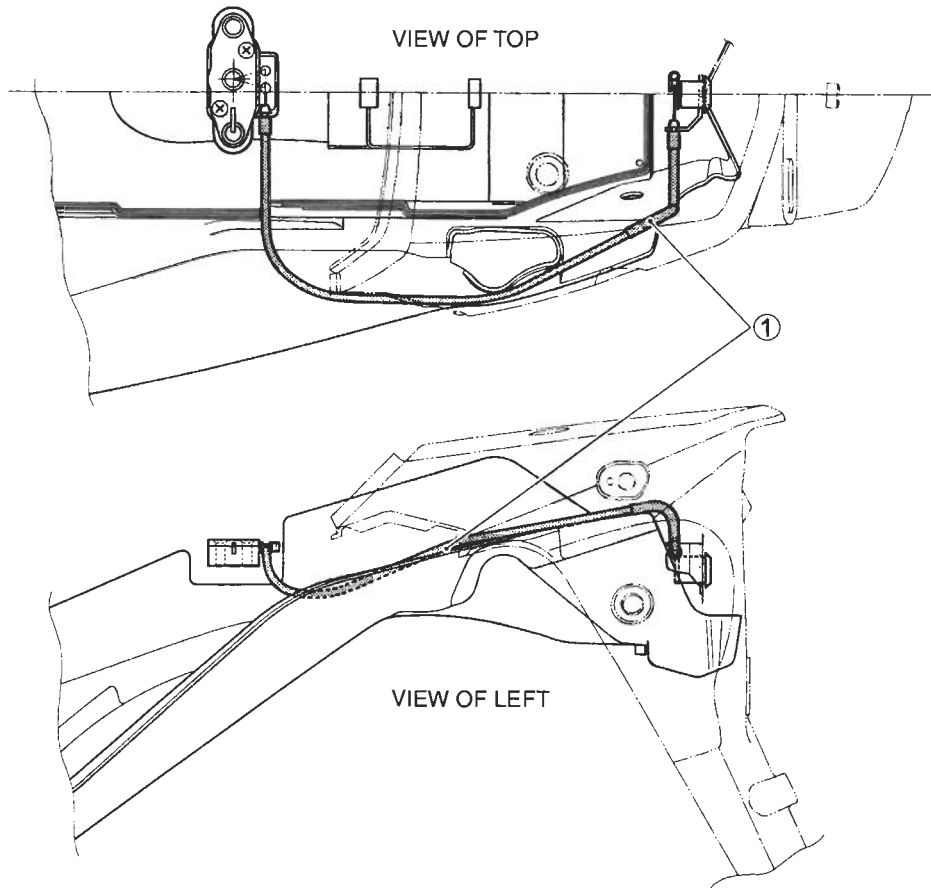

① Seat lock cable

## HEAD LAMP SET-UP

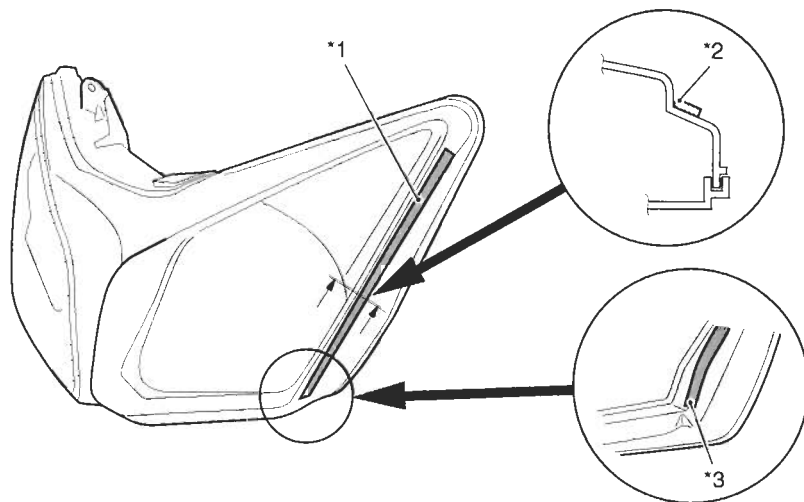

*1	Adhere cushion along the ridge line of lens.	*3	Right and left cushions shall be attached symmetrically.
*2	Start to adhere cushion from the corner of lens.		

## ABSORBER HOSE ROUTING

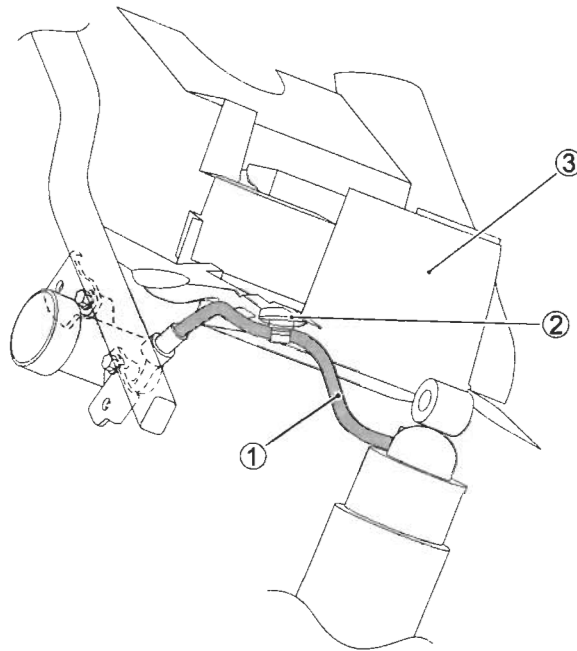

①	Absorber hose	③	Rear fender (Front)
②	Clamp		

## BATTERY CUSHION INSTALLATION

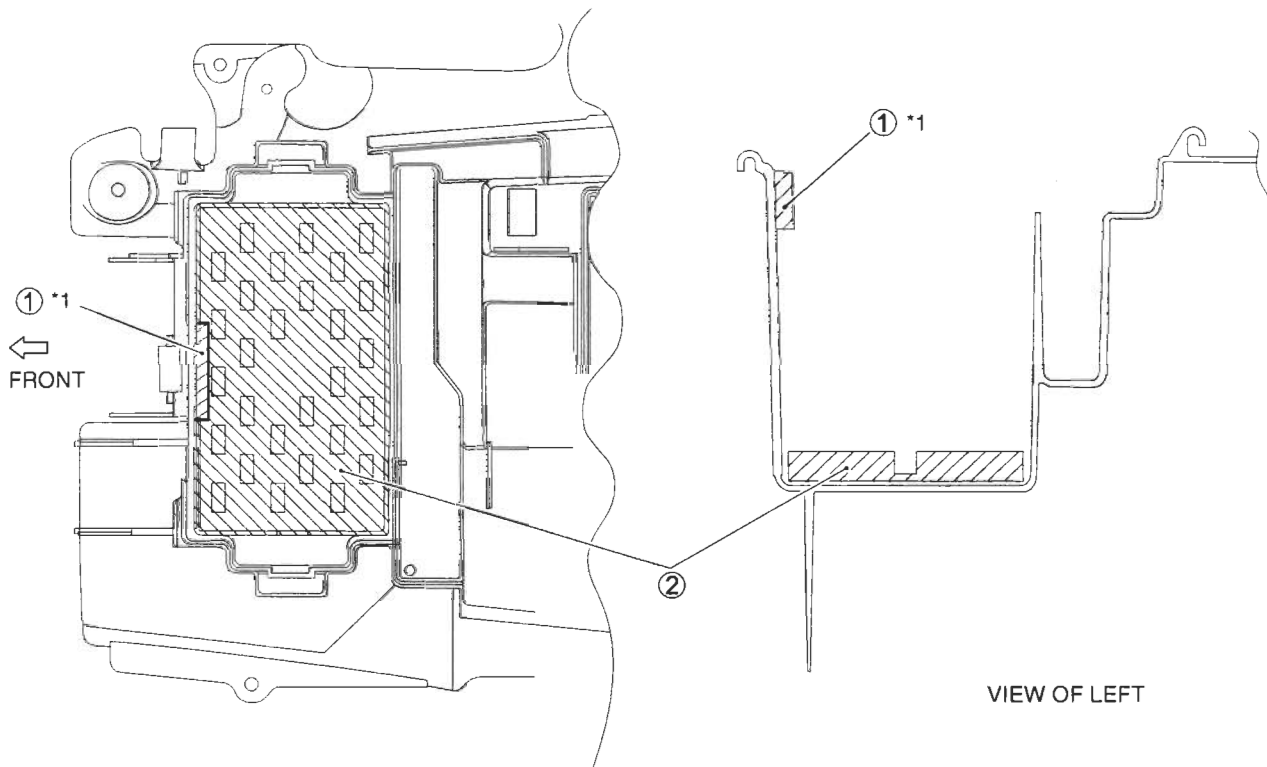

①②	Battery protector	*1	Adhere battery protector at the upper end.
----	-------------------	----	--

**SIDE-STAND SET-UP**

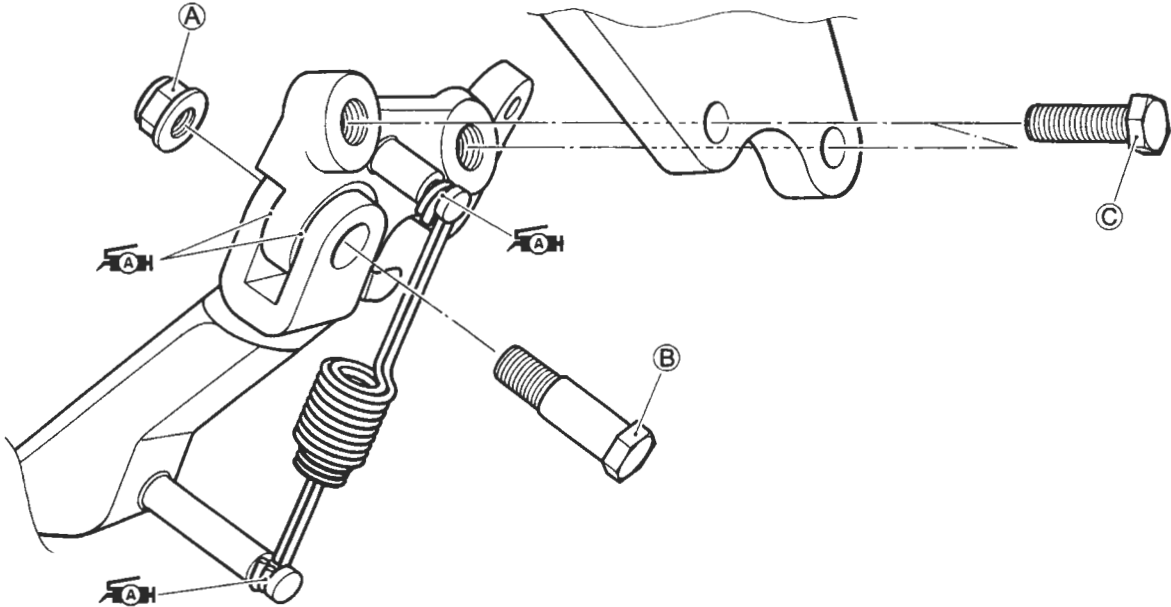

ITEM	N-m	kgf-m	lb-ft
(A)	40	4.0	29.0
(B)	50	5.0	36.0
(C)	100	10.0	72.5

**BRAKE PEDAL/FOOTREST SET-UP**

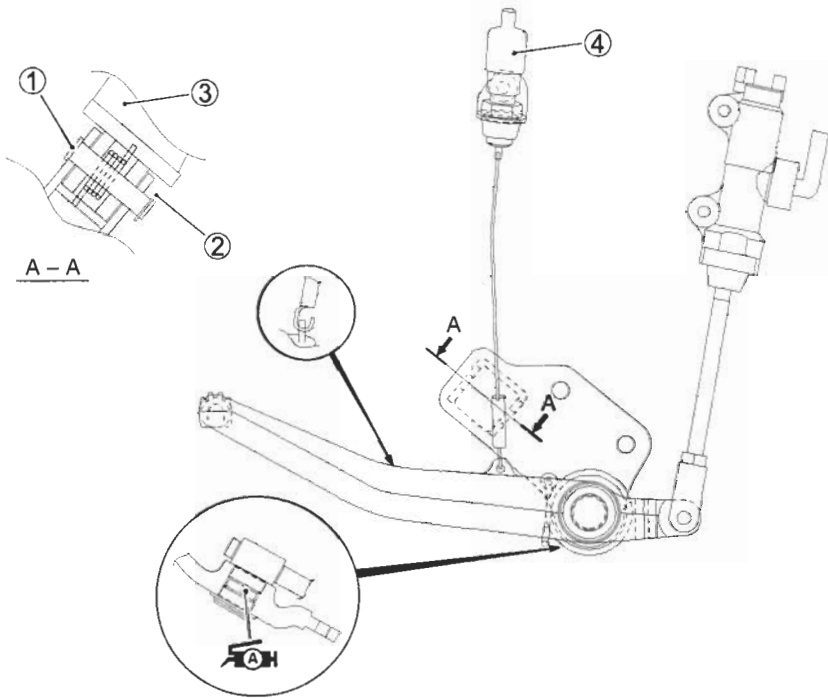

① Pin	③ Footrest
② E-ring	④ Brake light switch



# ENGINE CAP INSTALLATION

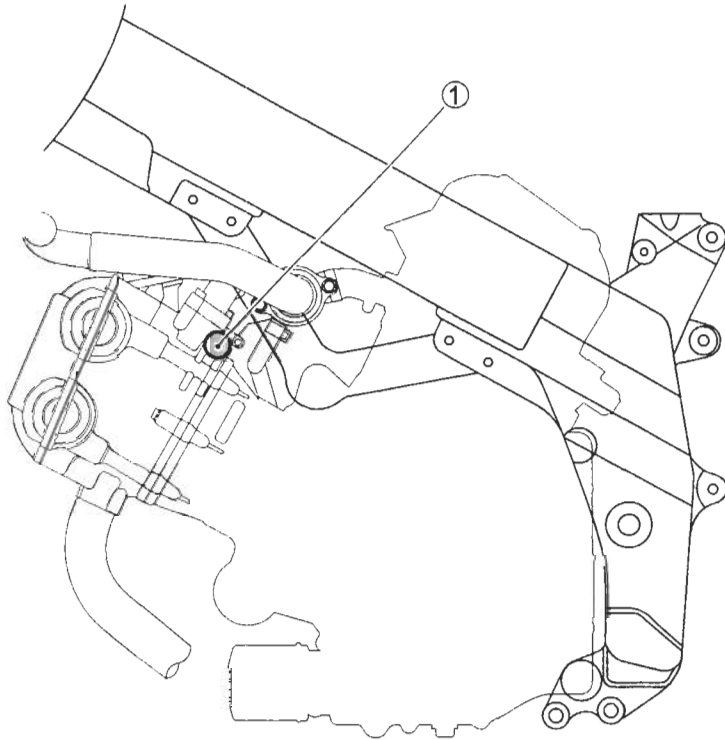

VIEW OF LEFT

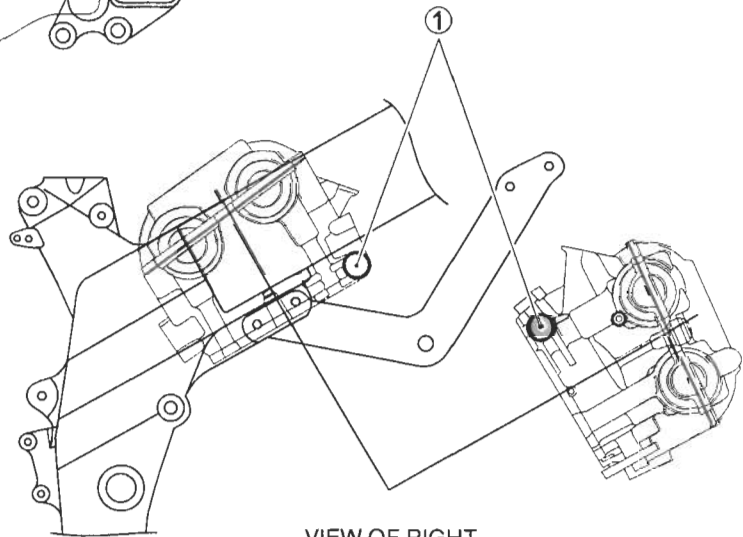

VIEW OF RIGHT

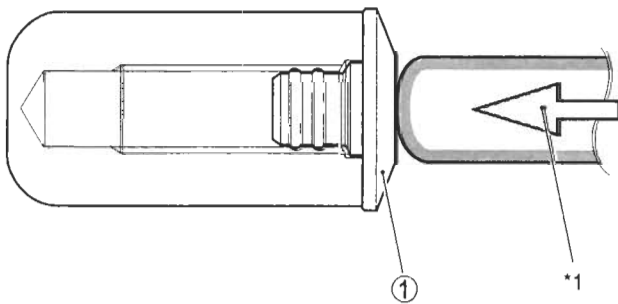

①	Engine cap	*1	Push the center of cap so as to thoroughly remove looseness.
---	------------	----	--

## FOOTREST SET-UP

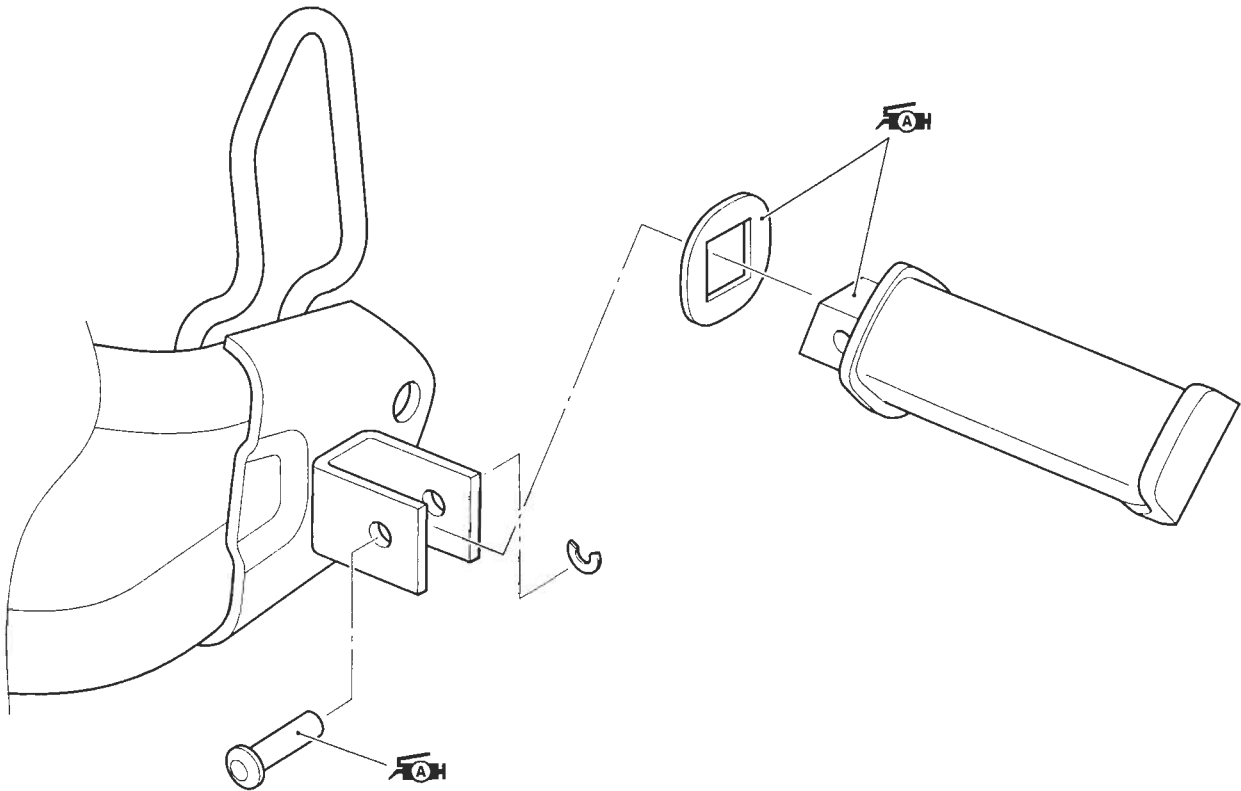

## HANDLEBAR BALANCER INSTALLATION

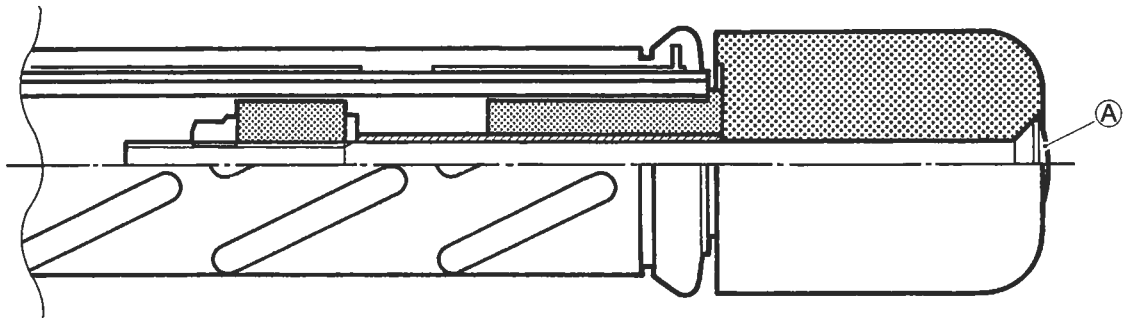







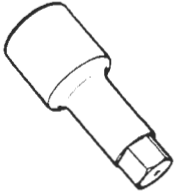
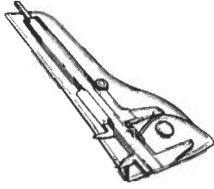
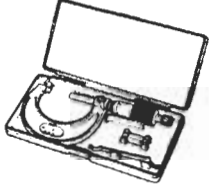
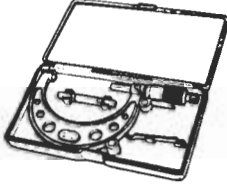

ITEM	N·m	kgf·m	lb·ft
Ⓐ	5.5	0.55	4



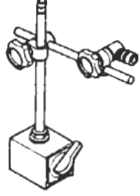
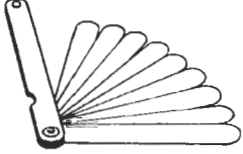
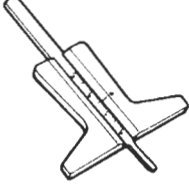
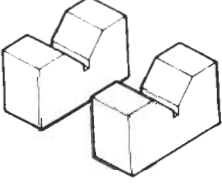

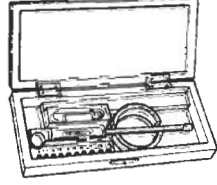
**NOTE:**

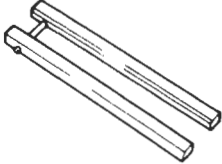
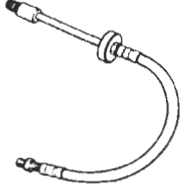
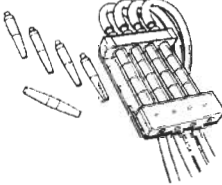
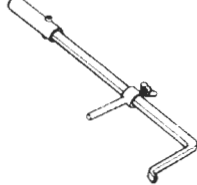

After installing the RH balancer weight, check that throttle grip rotate smoothly by turning it.

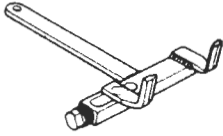
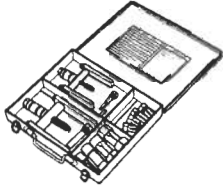
## SPECIAL TOOLS

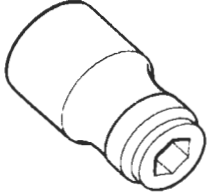
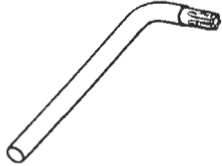
 <p><b>09900-18710</b> Hexagon bit 12 mm</p>	 <p><b>09900-20101</b> <b>09900-20102</b> Vernier calipers</p>	 <p><b>09900-20202</b> Micrometer (25 – 50 mm)</p>	 <p><b>09900-20204</b> Micrometer (75 – 100 mm)</p>	 <p><b>09900-20205</b> Micrometer (0 – 25 mm)</p>
 <p><b>09900-20508</b> Cylinder gauge set</p>	 <p><b>09900-20602</b> Dial gauge (1/1000 mm, 1 mm)</p>	 <p><b>09900-20607</b> Dial gauge (1/100 mm, 10 mm)</p>	 <p><b>09900-20701</b> Magnetic stand</p>	 <p><b>09900-20803</b> <b>09900-20806</b> Thickness gauge</p>
 <p><b>09900-20805</b> Tire depth gauge</p>	 <p><b>09900-21304</b> V-block set (100 mm)</p>	 <p><b>09900-22301</b> <b>09900-22302</b> Plastigauge</p>	 <p><b>09900-22403</b> Small bore gauge (18 – 35 mm)</p>	 <p><b>09900-25008</b> Multi circuit tester set</p>
 <p><b>09900-25009</b> Needle pointed probe set</p>	 <p><b>09910-20116</b> Conrod holder</p>	 <p><b>09913-10750</b> Adaptor</p>	 <p><b>09913-13121</b> Vacuum balancer gauge</p>	 <p><b>09913-50121</b> Oil seal remover</p>

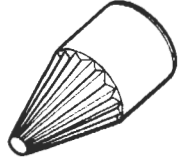
 <p><b>09913-60221</b> Journal bearing remover/installer</p>	 <p><b>09913-70210</b> Bearing installer set</p>	 <p><b>09915-40610</b> Oil filter wrench</p>	 <p><b>09915-64512</b> Compression gauge</p>	 <p><b>09915-74511</b> Oil pressure gauge set</p>
 <p><b>09915-74521</b> Oil pressure gauge hose</p>	 <p><b>09915-74532</b> Oil pressure gauge attachment</p>	 <p><b>09915-77331</b> Meter (for high pressure)</p>	 <p><b>09916-10911</b> Valve lapper set</p>	 <p><b>09916-14510</b> Valve lifter</p>
 <p><b>09916-14521</b> Valve lifter attachment</p>	 <p><b>09916-21111</b> Valve seat cutter set</p>	 <p><b>09916-20640</b> Solid pilot (N-100-4.5)</p>	 <p><b>09916-22430</b> Valve seat cutter head (N-128)</p>	 <p><b>09916-34542</b> Reamer handle</p>
 <p><b>09916-33210</b> Valve guide reamer (4.5 mm)</p>	 <p><b>09916-34580</b> Valve guide reamer (10.8 mm)</p>	 <p><b>09916-43210</b> Valve guide installer/remover</p>	 <p><b>09916-53330</b> Attachment</p>	 <p><b>09916-84511</b> Tweezers</p>

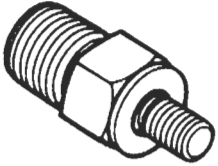
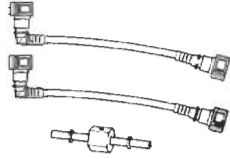
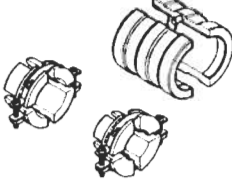
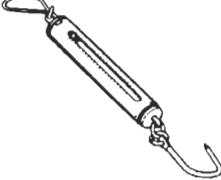
 <p><b>09917-47011</b> Vacuum pump gauge</p>	 <p><b>09920-13120</b> Crankcase separating tool</p>	 <p><b>09920-53740</b> Clutch sleeve hub holder</p>	 <p><b>09921-20240</b> Bearing remover set</p>	 <p><b>09924-84510</b> Bearing installer set</p>
 <p><b>09925-18011</b> Steering bearing installer</p>	 <p><b>09930-10121</b> Spark plug socket wrench set</p>	 <p><b>09930-11920</b> Torx bit JT40H</p>	 <p><b>09930-11940</b> Bit holder</p>	 <p><b>09930-11950</b> Torx wrench</p>
 <p><b>09930-11960</b> Torx wrench</p>	 <p><b>09930-30450</b> Rotor remover</p>	 <p><b>09930-44530</b> Rotor holder</p>	 <p><b>09930-82720</b> Mode select switch</p>	 <p><b>09940-14911</b> Steering stem nut wrench</p>
 <p><b>09940-14940</b> Swingarm pivot thrust adjuster socket wrench</p>	 <p><b>09940-14960</b> Steering stem nut wrench socket</p>	 <p><b>09940-14990</b> Engine mounting thrust adjuster socket wrench</p>	 <p><b>09940-34520</b> "T" Handle</p>	 <p><b>09940-34531</b> Attachment A</p>

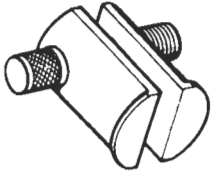
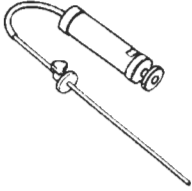
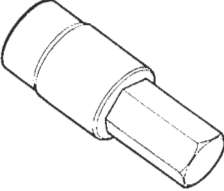
 <p><b>09940-40211</b> Fuel pressure gauge adaptor</p>	 <p><b>09940-40220</b> Fuel pressure gauge hose attachment</p>	 <p><b>09940-52861</b> Front fork oil seal installer</p>	 <p><b>09940-92720</b> Spring scale</p>	 <p><b>09941-34513</b> Bearing/steering race installer set</p>
 <p><b>09941-54911</b> Bearing outer race remover</p>	 <p><b>09943-74111</b> Front fork oil level gauge</p>	 <p><b>09944-28320</b> Hexagon bit 19 mm</p>		

**NOTE:**

*When order the special tool, please confirm whether it is available or not.*

## TIGHTENING TORQUE ENGINE

ITEM		N·m	kgf·m	lb·ft
Cylinder head cover bolt		14	1.4	10.0
Spark plug		11	1.1	8.0
Camshaft journal holder bolt		10	1.0	7.0
Cam chain tension adjuster cap bolt		8	0.8	5.7
Cam chain tension adjuster mounting bolt		10	1.0	7.0
Cylinder head bolt [M: 10]	Initial	25	2.5	18.0
	Final	42	4.2	30.5
Water drain bolt		13	1.3	9.5
Clutch sleeve hub nut		50	5.0	36.0
Clutch spring set bolt		10	1.0	7.0
Oil plate bolt		10	1.0	7.0
Oil pressure regulator		27	2.7	19.5
Oil strainer plate bolt		10	1.0	7.0
Primary drive gear bolt		70	7.0	50.5
Generator cover plug		10	1.0	7.0
Valve timing inspection plug		23	2.3	16.3
Generator rotor bolt		120	12.0	87
Starter clutch bolt		25	2.5	18.0
Generator stator set bolt		11	1.1	8.0
CKP sensor set bolt		6.5	0.65	4.7
Gearshift cam stopper bolt		10	1.0	7.0
Gearshift cam stopper plate bolt		13	1.3	9.5
Gearshift arm stopper bolt		19	1.9	13.5
Oil pressure switch		13	1.3	9.5
Crankcase bolt	[M: 6]	11	1.1	8.0
	[M: 8]	26	2.6	19.0
Generator cover bolt	[M: 6]	10	1.0	7.0
Oil gallery plug	[M: 8]	18	1.8	13.0
Oil drain plug		21	2.1	15.0
Piston cooling oil jet bolt		10	1.0	7.0
Conrod bearing cap bolt	Initial	21	2.1	15.0
	Final	After tightening the bolts to the above torque, tighten them 1/4 of a turn (90°).		

ITEM	N-m	kgf-m	lb-ft
Exhaust pipe bolt/nut	23	2.3	16.5
Muffler mounting bolt/nut	23	2.3	16.5
Oil pipe stopper screw	8	0.8	6.0
Engine sprocket nut	145	14.5	105
Engine mounting bolt/nut	55	5.5	40.0
Engine mounting nut	[Center]	93	9.3
Engine mounting thrust adjuster	12	1.2	8.5
Engine mounting thrust adjuster lock-nut	45	4.5	32.5
Engine mounting bracket bolt	35	3.5	25.5
Engine mounting pinch bolt	25	2.5	18.0
Cooling fan thermo-switch	17	1.7	12.5
ECT sensor	19	1.9	13.5
Fuel pump mounting bolt	10	1.0	7.0
Fuel delivery pipe mounting screw	5.0	0.5	3.7
Cooling fan/horn mounting bolt	8	0.8	6.0
Thermostat case bolt	10	1.0	7.0
Oil cooler mounting bolt	10	1.0	7.0
Oil cooler hose union bolt	23	2.3	16.5

## FI SYSTEM PARTS

ITEM	N-m	kgf-m	lb-ft
TP sensor mounting screw	3.5	0.35	2.5
STP sensor mounting screw	2.0	0.2	1.5
ECT sensor	19	1.9	13.5
IAT sensor	18	1.8	13.0



**CHASSIS**

ITEM	N-m	kgf-m	lb-ft
Steering stem head nut	90	9.0	65.0
Steering stem lock-nut	80	8.0	58.0
Front fork upper clamp bolt	23	2.3	16.5
Front fork lower clamp bolt	23	2.3	16.5
Front fork cap bolt	23	2.3	16.5
Front fork cylinder bolt	20	2.0	14.5
Front axle	65	6.5	47.0
Front axle pinch bolt	23	2.3	16.5
Handlebar clamp bolt	23	2.3	16.5
Front brake master cylinder mounting bolt	10	1.0	7.0
Front brake caliper mounting bolt	39	3.9	28.0
Brake hose union bolt	23	2.3	16.5
Front caliper air bleeder valve	7.5	0.75	5.5
Rear caliper air bleeder valve	6	0.6	4.3
Brake disc bolt (Front and Rear)	23	2.3	16.5
Rear brake caliper mounting bolt	22	2.2	16.0
Rear brake caliper sliding pin	27	2.7	19.5
Rear brake pad mounting pin	17	1.7	12.5
Rear brake pad mounting pin plug	2.5	0.25	1.8
Rear brake master cylinder mounting bolt	10	1.0	7.0
Rear brake master cylinder rod lock-nut	18	1.8	13.0
Front footrest bracket mounting bolt	25	2.5	18.0
Swingarm pivot shaft	15	1.5	11.0
Swingarm pivot nut	100	10.0	72.5
Swingarm pivot lock-nut	90	9.0	65.0
Rear shock absorber mounting nut (Upper & Lower)	50	5.0	36.0
Cushion lever nut	78	7.8	56.5
Cushion rod nut	78	7.8	56.5
Rear axle nut	100	10.0	72.5
Rear sprocket nut	60	6.0	43.5
Seat rail mounting bolt	50	5.0	36.0
Side stand bracket mounting bolt	100	10.0	72.5
Side stand bolt	50	5.0	36.0
Side stand nut	40	4.0	29.0

## TIGHTENING TORQUE CHART

For other nuts and bolts not listed in the preceding page, refer to this chart:

Bolt Diameter Ⓐ (mm)	Conventional or "4" marked bolt			"7" marked bolt		
	N·m	kgf·m	lb-ft	N·m	kgf·m	lb-ft
4	1.5	0.15	1.0	2.3	0.23	1.5
5	3	0.3	2.0	4.5	0.45	3.0
6	5.5	0.55	4.0	10	1.0	7.0
8	13	1.3	9.5	23	2.3	16.5
10	29	2.9	21.0	50	5.0	36.0
12	45	4.5	32.5	85	8.5	61.5
14	65	6.5	47.0	135	13.5	97.5
16	105	10.5	76.0	210	21.0	152.0
18	160	16.0	115.5	240	24.0	173.5

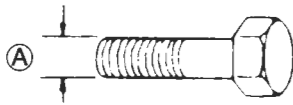

Conventional bolt

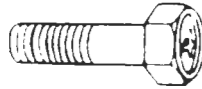

"4" marked bolt

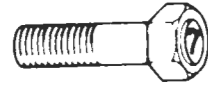

"7" marked bolt

## SERVICE DATA

### VALVE + GUIDE

Unit: mm (in)

ITEM	STANDARD		LIMIT
Valve diam.	IN.	31 (1.2)	—
	EX.	25.5 (1.0)	—
Valve clearance (when cold)	IN.	0.10 – 0.20 (0.004 – 0.008)	—
	EX.	0.20 – 0.30 (0.008 – 0.012)	—
Valve guide to valve stem clearance	IN.	0.020 – 0.047 (0.0008 – 0.0019)	—
	EX.	0.030 – 0.057 (0.0012 – 0.0022)	—
Valve guide I.D.	IN. & EX.	4.500 – 4.512 (0.1772 – 0.1776)	—
Valve stem O.D.	IN.	4.465 – 4.480 (0.1758 – 0.1764)	—
	EX.	4.455 – 4.470 (0.1754 – 0.1760)	—
Valve stem deflection	IN. & EX.	—	0.35 (0.014)
Valve stem runout	IN. & EX.	—	0.05 (0.002)
Valve head thickness	IN. & EX.	—	0.5 (0.02)
Valve seat width	IN. & EX.	0.9 – 1.1 (0.035 – 0.043)	—
Valve head radial runout	IN. & EX.	—	0.03 (0.001)
Valve spring free length (IN. & EX.)	INNER	—	36.8 (1.45)
	OUTER	—	39.8 (1.57)
Valve spring tension (IN. & EX.)	INNER	4.2 – 4.8 kgf (9.26 – 10.58 lbs) at length 29.9 mm (1.18 in)	—
	OUTER	17.0 – 19.6 kgf (37.48 – 43.21 lbs) at length 33.4 mm (1.31 in)	—

**CAMSHAFT + CYLINDER HEAD**

Unit: mm (in)

ITEM	STANDARD		LIMIT
Cam height	IN.	35.48 – 35.53 (1.3968 – 1.3988)	35.18 (1.3850)
	EX.	33.48 – 33.53 (1.3181 – 1.3201)	33.18 (1.3063)
Camshaft journal oil clearance	IN. & EX.	0.032 – 0.066 (0.0013 – 0.0026)	0.150 (0.0059)
Camshaft journal holder I.D.	IN. & EX.	22.012 – 22.025 (0.8666 – 0.8671)	—
Camshaft journal O.D.	IN. & EX.	21.959 – 21.980 (0.8645 – 0.8654)	—
Camshaft runout	IN. & EX.	—	0.10 (0.004)
Cam chain pin (at arrow "3")	16th pin		—
Cylinder head distortion	—		0.05 (0.002)

**CYLINDER + PISTON + PISTON RING**

Unit: mm (in)

ITEM	STANDARD		LIMIT
Compression pressure	1 300 – 1 700 kPa (13 – 17 kgf/cm <sup>2</sup> ) (185 – 242 psi)		1 100 kPa (11 kgf/cm <sup>2</sup> ) (156 psi)
Compression pressure difference	—		200 kPa (2 kgf/cm <sup>2</sup> ) (28 psi)
Piston to cylinder clearance	0.055 – 0.065 (0.0022 – 0.0026)		0.120 (0.0047)
Cylinder bore	81.000 – 81.015 (3.1890 – 3.1896)		Nicks or Scratches
Piston diam.	80.950 – 80.955 (3.1870 – 3.1872) Measure at 20 mm (0.79 in) from the skirt end.		80.88 (3.184)
Cylinder distortion	—		0.05 (0.002)
Piston ring free end gap	1st	Approx. 9.5 (0.37)	7.6 (0.30)
	2nd	Approx. 11 (0.43)	8.8 (0.35)
Piston ring end gap	1st	0.20 – 0.35 (0.008 – 0.014)	0.70 (0.028)
	2nd	0.20 – 0.35 (0.008 – 0.0014)	0.70 (0.028)
Piston ring to groove clearance	1st	—	0.180 (0.0071)
	2nd	—	0.150 (0.0059)
Piston ring groove width	1st	1.21 – 1.23 (0.0476 – 0.0484)	—
	2nd	1.01 – 1.03 (0.0398 – 0.0406)	—
	Oil	2.01 – 2.03 (0.0791 – 0.0799)	—
Piston ring thickness	1st	1.17 – 1.19 (0.0461 – 0.0469)	—
	2nd	0.97 – 0.99 (0.0382 – 0.0390)	—
Piston pin bore	20.002 – 20.008 (0.7875 – 0.7877)		20.030 (0.7886)
Piston pin O.D.	19.992 – 20.000 (0.7871 – 0.7874)		19.98 (0.7866)

**CONROD + CRANKSHAFT**

Unit: mm (in)

ITEM	STANDARD	LIMIT
Conrod small end I.D.	20.010 – 20.018 (0.7878 – 0.7881)	20.040 (0.7890)
Conrod big end side clearance	0.170 – 0.320 (0.0067 – 0.0126)	0.5 (0.02)
Conrod big end width	20.95 – 21.00 (0.825 – 0.827)	—
Crank pin width	42.17 – 42.22 (1.660 – 1.662)	—
Conrod big end oil clearance	0.032 – 0.056 (0.0013 – 0.0022)	0.080 (0.0031)
Crank pin O.D.	37.976 – 38.000 (1.4951 – 1.4960)	—
Crankshaft journal oil clearance	0.002 – 0.029 (0.0001 – 0.0011)	0.080 (0.0031)
Crankshaft journal O.D.	41.985 – 42.000 (1.6529 – 1.6535)	—
Crankshaft runout	—	0.05 (0.002)

**OIL PUMP**

ITEM	STANDARD	LIMIT
Oil pressure (at 60 °C, 140 °F)	Above 100 kPa (1.0 kgf/cm <sup>2</sup> , 14 psi) Below 400 kPa (4.0 kgf/cm <sup>2</sup> , 57 psi) at 3 000 r/min.	—

**CLUTCH**

Unit: mm (in)

ITEM	STANDARD	LIMIT
Clutch cable play	10 – 15 (0.4 – 0.6)	—
Clutch release screw	1/4 turns back	—
Drive plate thickness	No.1 & No.2 2.92 – 3.08 (0.115 – 0.121)	2.62 (0.103)
Drive plate claw width	No.1 & No.2 13.7 – 13.8 (0.539 – 0.543)	12.9 (0.507)
Driven plate distortion	—	0.10 (0.004)
Clutch spring free length	53.1 (2.09)	50.5 (1.99)

**TRANSMISSION + DRIVE CHAIN**

Unit: mm (in) Except ratio

ITEM		STANDARD	LIMIT
Primary reduction ratio		2.088 (71/34)	—
Final reduction ratio		3.133 (47/15)	—
Gear ratios	Low	2.461 (32/13)	—
	2nd	1.777 (32/18)	—
	3rd	1.380 (29/21)	—
	4th	1.125 (27/24)	—
	5th	0.961 (25/26)	—
	Top	0.851 (23/27)	—
Shift fork to groove clearance		0.1 – 0.3 (0.004 – 0.012)	0.50 (0.020)
Shift fork groove width		5.5 – 5.6 (0.217 – 0.220)	—
Shift fork thickness		5.3 – 5.4 (0.209 – 0.213)	—
Drive chain	Type	DID525V8	—
	Links	116 links	—
	20-pitch length	—	319.4 (12.57)
	Drive chain slack (on side-stand)	20 – 30 (0.79 – 1.18)	—
Gearshift lever height		25 (0.98)	—

**THERMOSTAT + RADIATOR + FAN + COOLANT**

ITEM	STANDARD		NOTE
Thermostat valve opening temperature	Approx. 88 °C (190 °F)		—
Thermostat valve lift	Over 8.0 mm (0.31 in) at 100 °C (212 °F)		—
ECT sensor resistance	20 °C (68 °F)	Approx. 2.45 kΩ	—
	40 °C (104 °F)	Approx. 1.148 kΩ	—
	60 °C (140 °F)	Approx. 0.587 kΩ	—
	80 °C (176 °F)	Approx. 0.322 kΩ	—
Radiator cap valve opening pressure	95 – 125 kPa (0.95 – 1.25 kgf/cm <sup>2</sup> , 13.5 – 17.8 psi)		—
Cooling fan thermo-switch operating temperature	OFF→ON	Approx. 98 °C (208 °F)	—
	ON→OFF	Approx. 92 °C (198 °F)	—
Engine coolant type	Use an antifreeze/coolant compatible with aluminum radiator, mixed with distilled water only, at the ratio of 50:50.		—
Engine coolant including reserve	Reserve tank side	Approx. 250 ml (0.53/0.44 US/lmp qt)	—
	Engine side	Approx. 1650 ml (3.49/2.90 US/lmp qt)	—

**INJECTOR + FUEL PUMP + FUEL PRESSURE REGULATOR**

ITEM	SPECIFICATION	NOTE
Injector resistance	11 – 13 Ω at 20 °C (68 °F)	
Fuel pump discharge amount	MIN. 168 ml (5.7/5.9 US/lmp oz) for 10 sec. at 300 kPa (3.0 kgf/cm <sup>2</sup> , 43 psi)	
Fuel pressure regulator operating set pressure	Approx. 300 kPa (3.0 kgf/cm <sup>2</sup> , 43 psi)	



**FI SENSORS+ SECONDARY THROTTLE VALVE ACTUATOR**

ITEM	SPECIFICATION		NOTE
CKP sensor resistance	130 – 240 $\Omega$		W – G
CKP sensor peak voltage	3.7 V (When cranking) and more		
IAP sensor input voltage	4.5 – 5.5 V		
IAP sensor output voltage	Approx. 2.7 V at idle speed		⊕ G/B – ⊖ B/Br
TP sensor input voltage	4.5 – 5.5 V		
TP sensor resistance	Closed	Approx. 1.12 k $\Omega$	
	Opened	Approx. 4.26 k $\Omega$	
TP sensor output voltage	Closed	Approx. 1.12 V	⊕ P/W – ⊖ B/Br
	Opened	Approx. 4.26 V	
ECT sensor input voltage	4.5 – 5.5 V		
ECT sensor resistance	Approx. 2.45 k $\Omega$ at 20 °C (68 °F)		
IAT sensor input voltage	4.5 – 5.5 V		
IAT sensor resistance	Approx. 2.45 k $\Omega$ at 20 °C (68 °F)		
TO sensor resistance	19.1 – 19.7 k $\Omega$		
TO sensor voltage	Normal	0.4 – 1.4 V	⊕ Br/W – ⊖ B/Br
	Leaning 65 °	3.7 – 4.4 V	
GP switch voltage	1.0 V and more (From 1st to Top)		
Injector voltage	Battery voltage		
STP sensor input voltage	4.5 – 5.5 V		
STP sensor resistance	Closed	Approx. 0.58 k $\Omega$	Y – B
	Opened	Approx. 4.38 k $\Omega$	
STP sensor output voltage	Closed	Approx. 0.58 V	⊕ Y – ⊖ B/Br
	Opened	Approx. 4.40 V	
STV actuator resistance	7 – 14 $\Omega$		
PAIR solenoid valve resistance	20 – 24 k $\Omega$ at 20 °C (68 °F)		

**THROTTLE BODY**

ITEM	SPECIFICATION
I.D. No.	27 G0 (Others), 27 G1 (For E-33)
Bore size	39 mm
Fast idle r/min.	1 800 – 2 400 r/min at 25 °C (77 °F)
Idle r/min.	1 300 ± 100 r/min/Warmed engine
Throttle cable play	2.0 – 4.0 mm (0.08 – 0.16 in)

**ELECTRICAL**

Unit: mm (in)

ITEM		SPECIFICATION		NOTE
Firing order		1.2		
Spark plug		Type	NGK: CR8E DENSO: U24ESR-N	
		Gap	0.7 – 0.8 mm (0.028 – 0.031 in)	
Spark performance		Over 8 mm (0.3 in) at 1 atm.		
CKP sensor resistance		130 – 240 $\Omega$		W – G
Ignition coil resistance		Primary	2 – 5 $\Omega$	⊕ tap – ⊖ tap
		Secondary	24 – 37 k $\Omega$	⊕ tap – Plug cap
CKP sensor peak voltage		3.7 V and more		When cranking
Ignition coil primary peak voltage		150 V and more		
Generator coil resistance		0.2 – 0.7 $\Omega$		
Generator Max. output		Approx. 375 W at 5 000 r/min		
Generator no-load voltage (When cold)		60 V (AC) and more at 5 000 r/min.		
Regulated voltage		14.0 – 15.5 V at 5 000 r/min.		
Starter relay resistance		3 – 6 $\Omega$		
Battery	Type designation	YTX12-BS		
	Capacity	12 V 36.0 kC (10 Ah)/10 HR		
Fuse size	Headlight	HI	15 A	
		LO	15 A	
	Fuel	10 A		
	Ignition	10 A		
	Fan motor	15 A		
	Signal	15 A		
	Main	30 A		

**WATTAGE**

Unit: W

ITEM	SPECIFICATION	
	E-03, 24, 28, 33	Others
Headlight	12 V 60/55 W × 2 (H4)	←
Position/Parking light		12 V 5 W × 2
Brake light/Taillight	12 V 21/5 W × 2	←
Turn signal light	12 V 21 W	←
License light	12 V 5 W	←
Speedometer light	LED	←
Turn signal indicator light	LED	←
High beam indicator light	LED	←
Neutral indicator light	LED	←
Oil pressure/Coolant temp./Fuel injection warning	LED	←

**BRAKE + WHEEL**

Unit: mm (in)

ITEM	STANDARD		LIMIT
Rear brake pedal height	15 – 25 (0.59 – 0.98)		—
Brake disc thickness	Front	5 (0.20)	4.5 (0.18)
	Rear	5 (0.20)	4.5 (0.18)
Brake disc runout	—		0.3 (0.012)
Master cylinder bore	Front	15.870 – 15.913 (0.6248 – 0.6265)	—
	Rear	14.000 – 14.043 (0.5512 – 0.5529)	—
Master cylinder piston diam.	Front	15.827 – 15.854 (0.6231 – 0.6242)	—
	Rear	13.957 – 13.984 (0.5495 – 0.5506)	—
Brake caliper cylinder bore	Front	30.230 – 30.306 (1.1902 – 1.1931)	—
	Rear	38.180 – 38.256 (1.5031 – 1.5061)	—
Brake caliper piston diam.	Front	30.150 – 30.200 (1.1870 – 1.1890)	—
	Rear	38.098 – 38.148 (1.4999 – 1.5019)	—
Brake fluid type	DOT 4		
Wheel rim runout	Axial	—	2.0 (0.08)
	Radial	—	2.0 (0.08)
Wheel rim size	Front	19 M/C × MT2.50	—
	Rear	17 M/C × MT4.00	—
Wheel axle runout	Front	—	0.25 (0.010)
	Rear	—	0.25 (0.010)

**TIRE**

ITEM	STD/SPEC.		LIMIT
Cold inflation tire pressure (Solo riding)	Front	225 kPa (2.25 kgf/cm <sup>2</sup> , 33 psi)	—
	Rear	250 kPa (2.50 kgf/cm <sup>2</sup> , 36 psi)	—
Cold inflation tire pressure (Dual riding)	Front	225 kPa (2.25 kgf/cm <sup>2</sup> , 33 psi)	—
	Rear	280 kPa (2.80 kgf/cm <sup>2</sup> , 41 psi)	—
Tire size	Front	110/80 R19 M/C (59 H)	—
	Rear	150/70 R17 M/C (69 H)	—
Tire type	Front	BRIDGESTONE: TW101 F	—
	Rear	BRIDGESTONE: TW152 F	—
Tire tread depth	Front	—	1.6 (0.06)
	Rear	—	2.0 (0.08)

**SUSPENSION**

Unit: mm (in)

ITEM	STD/SPEC.		LIMIT
Front fork stroke	150 (5.9)		—
Front fork spring free length	444.1 (17.5)		435 (17.1)
Front fork oil level (without spring, outer tube fully compressed)	143 (5.63)		—
Front fork spring adjuster	3 groove from Top/Spring adjuster height 9 mm (0.35 in)		—
Front fork oil type	SUZUKI FORK OIL SS-08 or equivalent fork oil		—
Front fork oil capacity (each leg)	524 ml (17.7/18.5 US/Imp oz)		—
Rear shock absorber spring adjuster	2 groove from bottom		—
Rear shock absorber damping force adjuster	Rebound	1 turn back from stiffest position	E-02, 19, 24
		1 1/2 turns back from stiffest position	E-03, 28, 33
Rear wheel travel	150 mm (5.9 in)		—
Swingarm pivot shaft runout	—		0.3 (0.01)

**FUEL + OIL**

ITEM	STD/SPEC.		NOTE
Fuel type	Use only unleaded gasoline of at least 87 pump octane ( $\frac{R+M}{2}$ ) or 91 octane or higher rated by the research method. Gasoline containing MTBE (Methyl Tertiary Butyl Ether), less than 10 % ethanol, or less than 5 % methanol with appropriate cosolvents and corrosion inhibitor is permissible.		E-03, 28, 33
	Gasoline used should be graded 91 octane or higher. An unleaded gasoline is recommended.		Others
Fuel tank capacity	22 L (5.8/4.8 US/Imp gal)		
Engine oil type	SAE 10 W – 40, API SF or SG		
Engine oil capacity	Change	2 300 ml (2.4/2.0 US/Imp qt)	
	Filter change	2 700 ml (2.9/2.4 US/Imp qt)	
	Overhaul	3 100 ml (3.3/2.7 US/Imp qt)	

# EMISSION CONTROL INFORMATION

## CONTENTS

<b>EMISSION CONTROL SYSTEMS .....</b>	<b>10- 2</b>
<b>FUEL INJECTION SYSTEM .....</b>	<b>10- 2</b>
<b>CRANKCASE EMISSION CONTROL SYSTEM .....</b>	<b>10- 3</b>
<b>EXHAUST EMISSION CONTROL SYSTEM (PAIR SYSTEM) .....</b>	<b>10- 4</b>
<b>NOISE EMISSION CONTROL SYSTEM .....</b>	<b>10- 5</b>
<b>EVAPORATIVE EMISSION CONTROL SYSTEM (Only for E-33) .....</b>	<b>10- 5</b>
<b>PAIR (AIR SUPPLY) SYSTEM INSPECTION .....</b>	<b>10- 6</b>
<b>HOSES .....</b>	<b>10- 6</b>
<b>PAIR REED VALVE .....</b>	<b>10- 6</b>
<b>PAIR CONTROL SOLENOID VALVE .....</b>	<b>10- 7</b>
<b>PAIR (AIR SUPPLY) SYSTEM HOSE ROUTING .....</b>	<b>10- 8</b>
<b>HEATED OXYGEN SENSOR (HO2S) WIRE ROUTING (E-02, 19) ....</b>	<b>10- 8</b>
<b>EVAPORATIVE EMISSION CONTROL SYSTEM INSPECTION</b>	
<b>(Only for E-33) .....</b>	<b>10-10</b>
<b>HOSES .....</b>	<b>10-10</b>
<b>EVAP CANISTER .....</b>	<b>10-10</b>
<b>FUEL-SHUT OFF VALVE .....</b>	<b>10-10</b>
<b>EVAP CANISTER HOSE ROUTING (Only for E-33) .....</b>	<b>10-11</b>

## EMISSION CONTROL SYSTEMS

### FUEL INJECTION SYSTEM

DL650 motorcycles are equipped with a fuel injection system for emission level control.

This fuel injection system is precision designed, manufactured and adjusted to comply with the applicable emission limits.

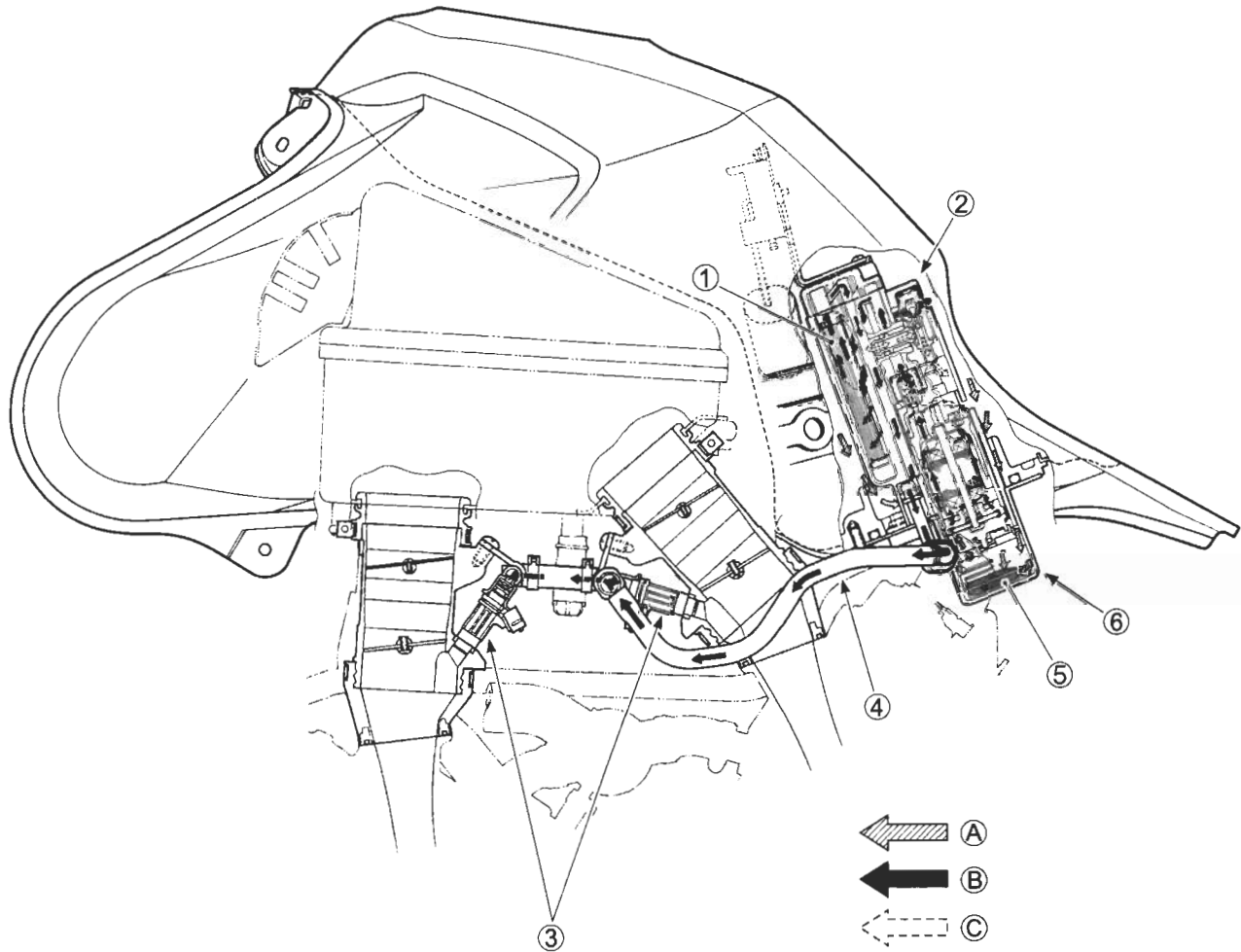

① Fuel filter (For high pressure)	Ⓐ BEFORE-PRESSURIZED FUEL
② Fuel pressure regulator	Ⓑ PRESSURIZED FUEL
③ Fuel injector	Ⓒ RELIEVED FUEL
④ Fuel feed hose	
⑤ Fuel mesh filter (For low pressure)	
⑥ Fuel pump	



## CRANKCASE EMISSION CONTROL SYSTEM

The engine is equipped with a PCV system. Blow-by gas in the engine is constantly drawn into the crankcase, which is returned to the combustion chamber through the breather hose, air cleaner and throttle body.

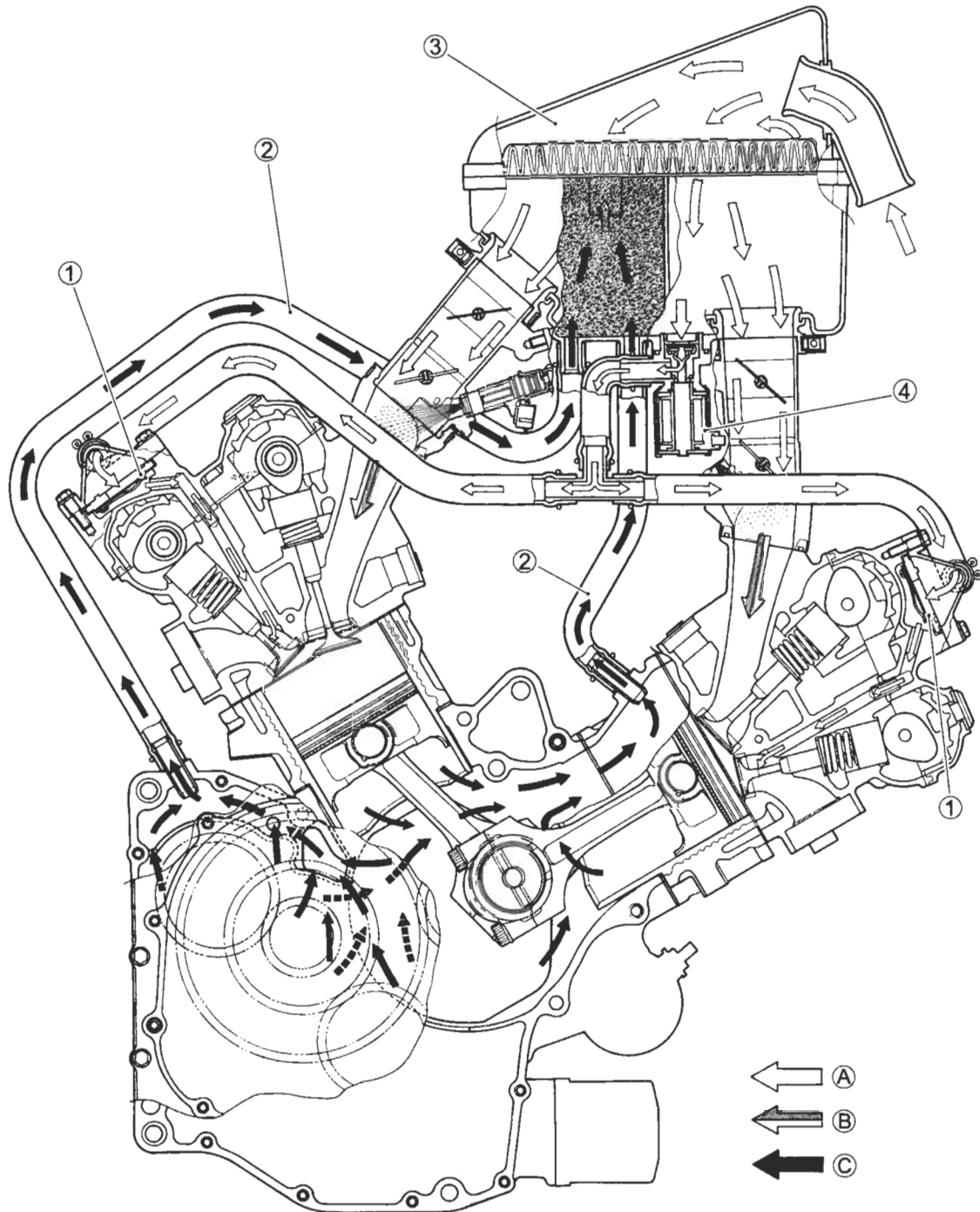

① PAIR reed valve	Ⓐ FRESH AIR
② Breather hose	Ⓑ FUEL/AIR MIXTURE
③ Air cleaner box	Ⓒ BLOW-BY GAS
④ PAIR control solenoid valve	

### EXHAUST EMISSION CONTROL SYSTEM (PAIR SYSTEM)

The exhaust emission control system is composed of the PAIR system and THREE-WAY CATALYST system. (Except for E-03, -24 and -28) The fresh air is drawn into the exhaust port with the PAIR solenoid valve and PAIR reed valve. The PAIR solenoid valve is operated by the ECM, and the fresh air flow is controlled according to the TPS, ECTS, IATS and IAPS.

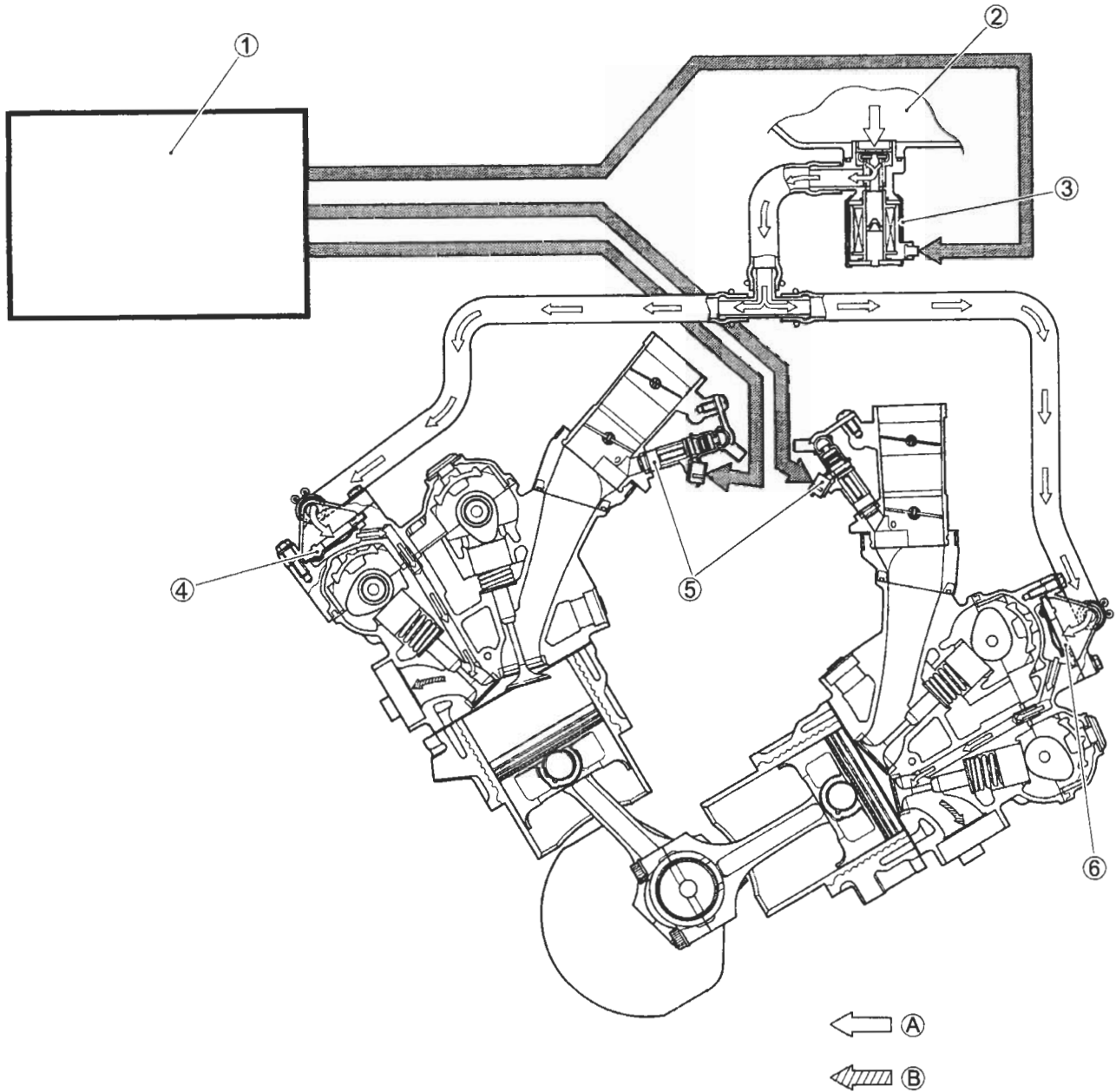

① ECM	⑤ Injector
② Air cleaner box	⑥ PAIR reed valve
③ PAIR control solenoid valve	Ⓐ FRESH AIR
④ PAIR reed valve	Ⓑ EXHAUST GAS

## NOISE EMISSION CONTROL SYSTEM

**TAMPERING WITH THE NOISE CONTROL SYSTEM PROHIBITED:** Federal law prohibits the following acts or the causing thereof:

1. The removal or rendering inoperative by any person, other than for purposes of maintenance, repair or replacement, of any device or element of design incorporated into any new vehicle for the purpose of noise control prior to its sale or delivery to the ultimate purchaser or while it is in use, or
2. The use of the vehicle after such device or element of design has been removed or rendered inoperative by any person.

### AMONG THOSE ACTS PRESUMED TO CONSTITUTE TAMPERING ARE THE ACTS LISTED BELOW:

- Removing or puncturing the muffler, baffles, header pipes, screen type spark arrester (if equipped) or any other component which conducts exhaust gases.
- Removing or puncturing the air cleaner case, air cleaner cover, baffles or any other component which conducts intake air.
- Replacing the exhaust system or muffler with a system or muffler not marked with the same model specific code as the code listed on the Motorcycle Noise Emission Control Information label.

## EVAPORATIVE EMISSION CONTROL SYSTEM (Only for E-33)

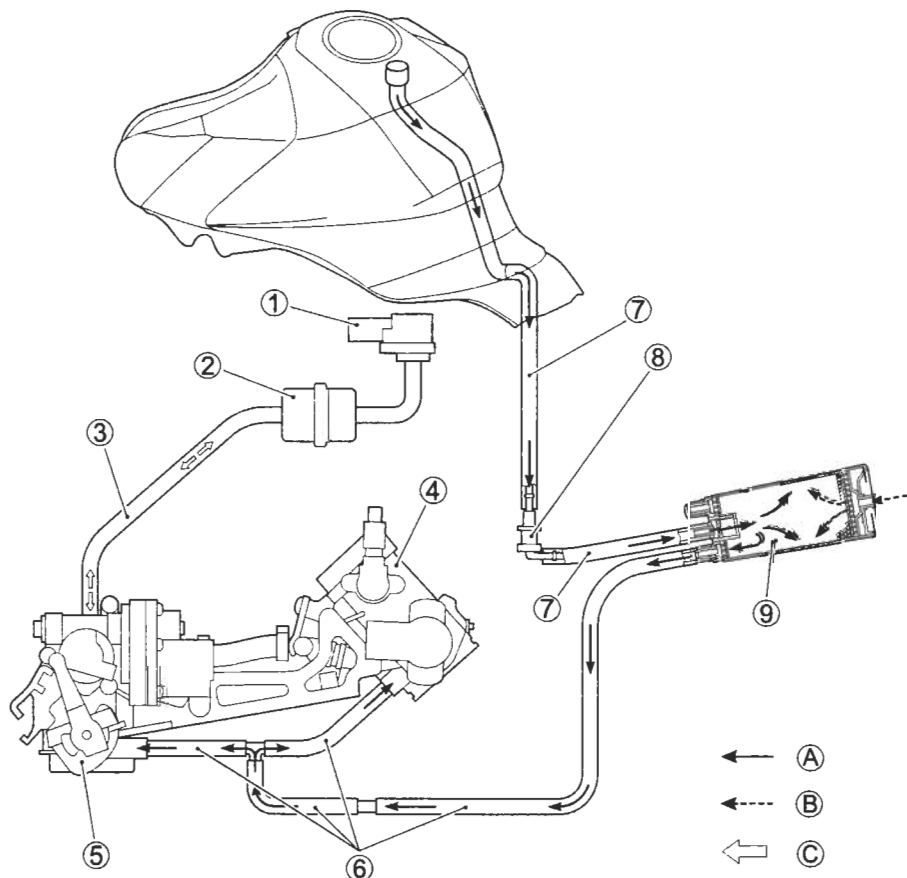

① IAP sensor	⑦ Surge hose
② Vacuum damper	⑧ Fuel shut-off valve
③ Vacuum hose	⑨ EVAP canister
④ No.2 Throttle body	A HC VAPOR
⑤ No.1 Throttle body	B FRESH AIR
⑥ Purge hose	C VACUUM

## PAIR (AIR SUPPLY) SYSTEM INSPECTION HOSES

- Inspect the hoses for wear or damage.
- Inspect that the hoses are securely connected.

## PAIR REED VALVE

- Remove the PAIR reed valve cover. (👉 3-36)
- Inspect the reed valve for the carbon deposit.
- If the carbon deposit is found in the reed valve, replace the PAIR reed valve with a new one
- Installation is in the reverse order of removal.



## PAIR CONTROL SOLENOID VALVE

- Remove the air cleaner box. (☞ 5-15)
- Remove the PAIR control solenoid valve ①.

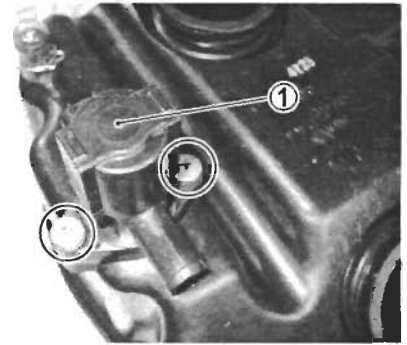

- Check that air flows through the air inlet port to the air outlet port.
- If air does not flow out, replace the PAIR control solenoid valve with a new one.

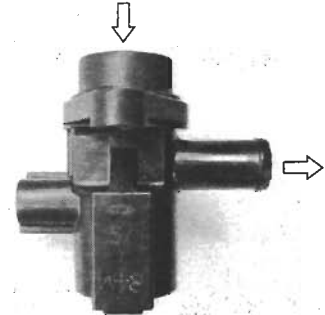

- Connect the 12 V battery to the PAIR control solenoid valve terminals and check the air flow.
- If air does not flow out, the solenoid valve is in normal condition.

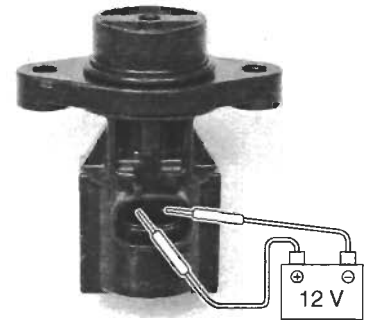

- Check the resistance between the terminals of the PAIR control solenoid valve.

**DATA** Resistance: 20 – 24  $\Omega$  (at 20 °C/68 °F)

**TOOL** 09900-25008: Multi circuit tester set

**TESTER** Tester knob indication: Resistance ( $\Omega$ )

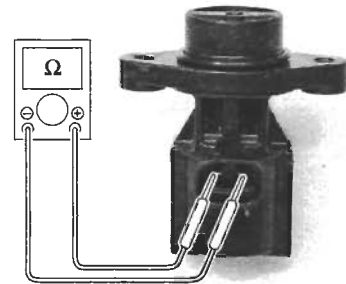

If the resistance is not within the standard range, replace the PAIR control solenoid valve with a new one.

- Connect the PAIR control solenoid valve lead wire coupler securely.
- Installation is in the reverse order of removal.

**PAIR (AIR SUPPLY) SYSTEM HOSE ROUTING**

 9-30

**HEATED OXYGEN SENSOR (HO2S) WIRE ROUTING (E-02, 19)**

 9-18



## HEATED OXYGEN SENSOR (HO2S) INSPECTION (E-02, 19)

- Remove the seat. (C/F 7-4)
- Disconnect the HO2 sensor coupler.
- Remove the HO2 sensor unit.

### ⚠ WARNING

Do not remove the HO2 sensor while it is hot.

### CAUTION

Be careful not to expose it to excessive shock.  
Do not use an impact wrench while removing or installing the HO2 sensor unit.  
Be careful not to twist or damage the sensor lead wire.

- Inspect the HO2 sensor and its circuit referring to flow table of the malfunction code (C44).
- Disconnect the HO2 sensor coupler.
- Check the resistance between the terminals (white – white) of the HO2 sensor.

**DATA** Resistance: 4 – 5  $\Omega$  (at 23 °C/73.4 °F)

**TOOL** 09900-25008: Multi circuit tester set

**TESTER** Tester knob indication: Resistance ( $\Omega$ )

If the resistance is not within the standard range, replace the HO2 sensor with a new one.

### NOTE:

- \* Temperature of the sensor affects resistance value largely.
- \* Make sure that the sensor heater is at correct temperature.
- Connect the HO2 sensor coupler securely.

- Installation is in the reverse order of removal.

### CAUTION

Do not apply oil or other materials to the sensor air hole.

- Tighten the sensor unit to the specified torque.

**TIGHTENING TORQUE** HO2 SENSOR: 47.5 N·m (4.75 kgf-m, 34.3 lb-ft)

- Route the HO2 sensor lead wire into the frame.
- Connect the HO2 sensor coupler.

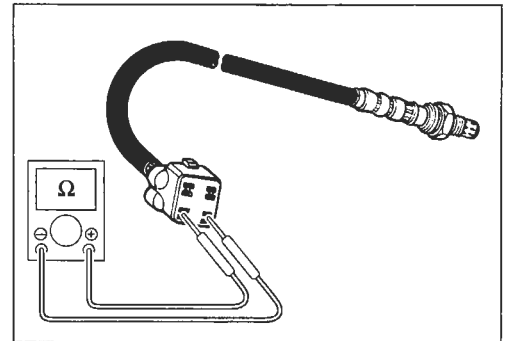

## EVAPORATIVE EMISSION CONTROL SYSTEM INSPECTION (Only for E-33)

- Remove the frame cover. (☞ 7-5)
- Lift and support the fuel tank with its prop stay. (☞ 5-7)

### HOSES

Inspect the hoses for wear or damage.

Make sure that the hoses are securely connected.

### EVAP CANISTER

Inspect the canister for damage to the body.

### FUEL-SHUT OFF VALVE

Inspect the fuel-shut off valve body for damage.

Inspect the fuel-shut off valve operation in the following procedure.

- Remove the fuel-shut off valve.
- When air is blown into the fuel-shut off valve with its side (A) positioned upward, the air can pass through to the canister side.
- When air is blown into the fuel-shut off valve with its side (A) positioned sideways, the air cannot pass through to the canister side.
- If the fuel-shut off valve operates otherwise, it must be replaced.

#### **⚠ WARNING**

**Gasoline and gasoline vapor is toxic. A small amount of fuel remains in the fuel-shut off valve when checking it.**

**Do not swallow the fuel when blowing the fuel-shut off valve.**

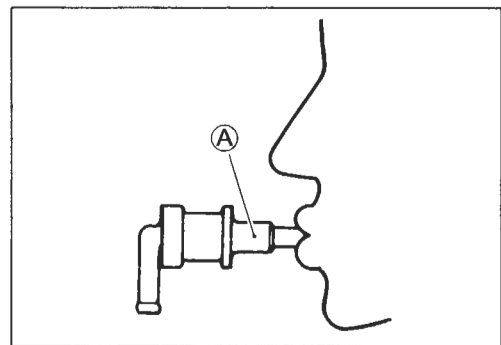
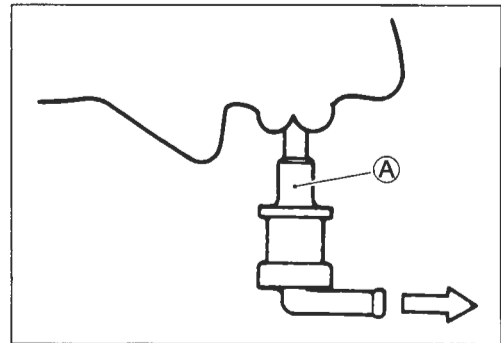



# EVAP CANISTER HOSE ROUTING (Only for E-33)

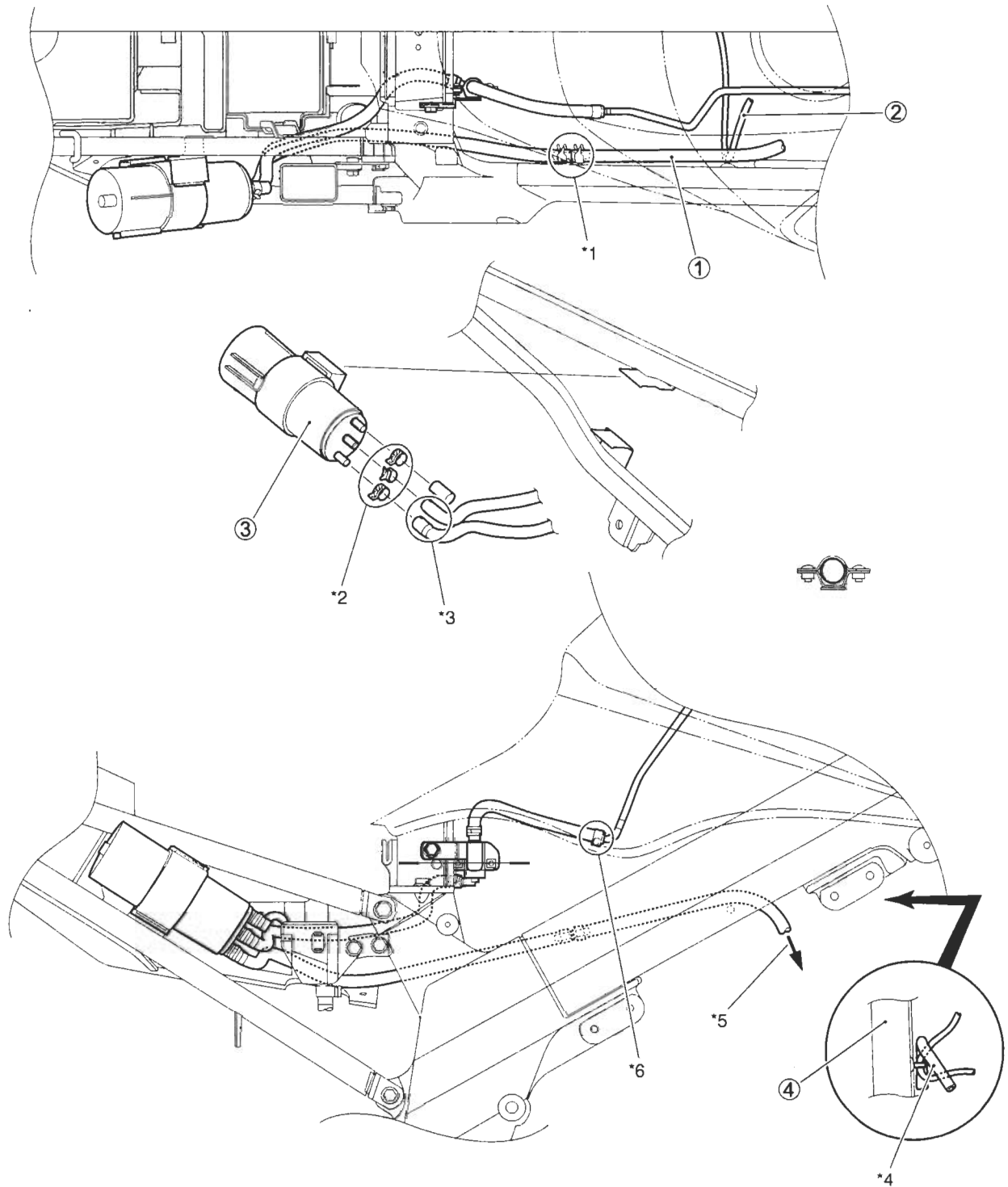

① Purge hose	*2 Clamp ends should face outside.
② Wiring harness	*3 White paint mark should face top side.
③ EVAP canister	*4 Pass through the purge hose between the frame and wiring harness.
④ Frame	*5 To throttle body.
*1 Clamp ends should face inside.	*6 Clamp ends should face down side.

DRAWING NUMBER: **N0023/2**  
 SHT 1 OF 1  
 REV **F**  
 SECY CLASS: UNCLASSIFIED

REV	DATE	DRN	APP	DESCRIPTION OF REVISION	ZONE	REF	THOR
B	25-05-04	RBS	MIS	HEATED GRIPS CIRCUIT CORRECTED			
C	09-06-04	RBS	MIS	O/B IN COLOUR CODE CORRECTED	L	2	
D	12-06-04	RBS	MIS	IGNITION SWITCH WIRING CORRECTED (IG & O/G WIRES ADDED)			
E	08-07-04	RBS	MIS	ABBREVIATIONS ADDED & TACHO WIRE COLOUR CORRECTED			
F	12-10-04	RBS	MIS	FLASHER RELAY CLARIFIED			

**INSTRUMENT CLUSTER**

**HANDLEBAR SWITCH (R)**

- SP SPEEDOMETER
- TA TACHOMETER
- IL INSTRUMENT LIGHT
- L TURN SIGNAL INDICATOR LIGHT (L)
- R TURN SIGNAL INDICATOR LIGHT (R)
- F FUEL GAUGE
- W TEMPERATURE GAUGE
- O OIL INDICATOR LIGHT
- N NEUTRAL INDICATOR LIGHT
- H HIGH BEAM INDICATOR LIGHT

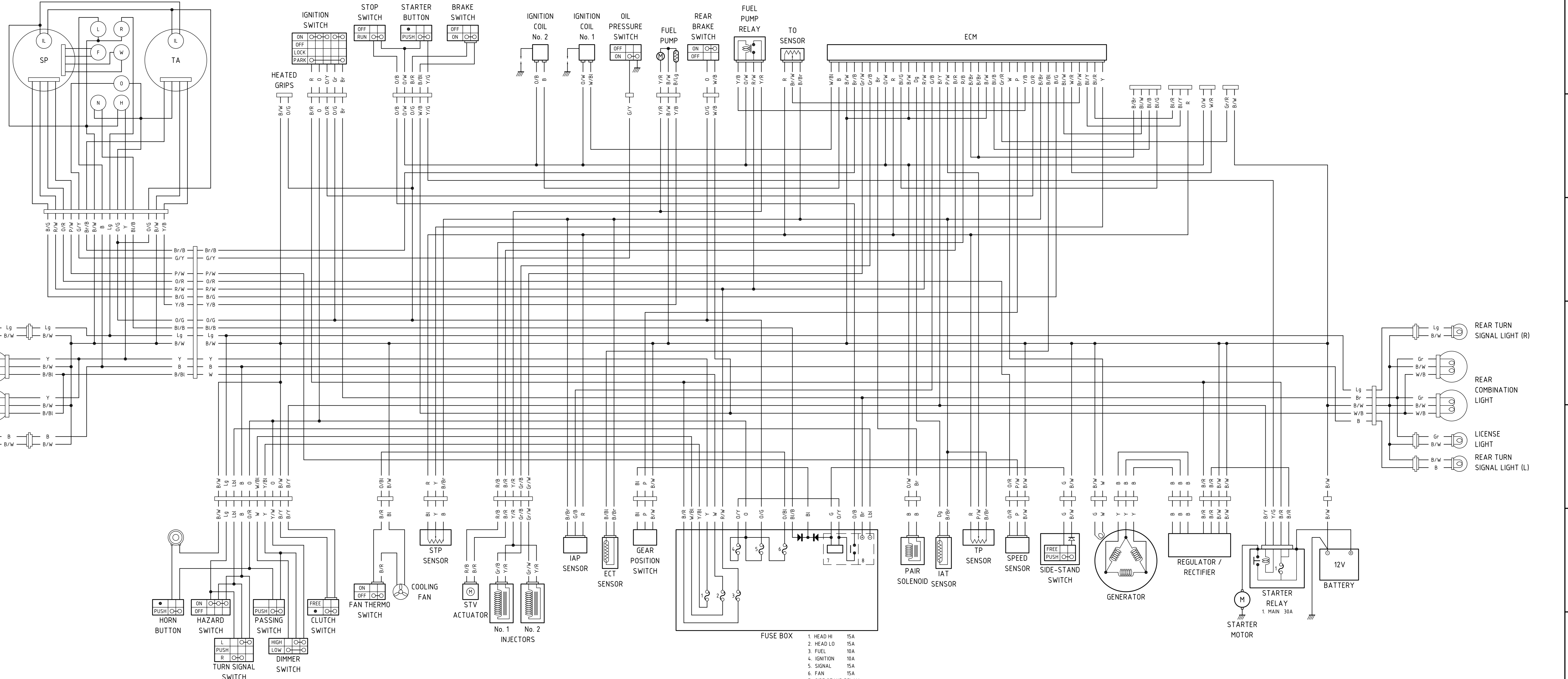

- FRONT TURN SIGNAL LIGHT (R)
- HEADLIGHT (R)
- HEADLIGHT (L)
- FRONT TURN SIGNAL LIGHT (L)

- REAR TURN SIGNAL LIGHT (R)
- REAR COMBINATION LIGHT
- LICENSE LIGHT
- REAR TURN SIGNAL LIGHT (L)

**WIRE COLOUR CODE**

B	BLACK
BL	BLUE
BR	BROWN
Dg	DARK GREEN
G	GREEN
Gr	GRAY
Lm	LIGHT BLUE
O	ORANGE
P	PINK
R	RED
W	WHITE
Y	YELLOW

**SENSOR ABBREVIATIONS**

ETC	ENGINE COOLANT TEMPERATURE
IAP	INTAKE AIR PRESSURE
IAT	INTAKE AIR TEMPERATURE
STP	SECONDARY THROTTLE POSITION
TO	TIP-OVER
TP	THROTTLE POSITION

**HANDLEBAR SWITCH (L)**

B/BI	BLACK WITH BLUE TRACER
BI/BL	BLACK WITH BROWN TRACER
B/G	BLACK WITH GREEN TRACER
B/O	BLACK WITH ORANGE TRACER
B/R	BLACK WITH RED TRACER
B/W	BLACK WITH WHITE TRACER
B/Y	BLACK WITH YELLOW TRACER
BI/B	BLUE WITH BLACK TRACER
BI/G	BLUE WITH GREEN TRACER
BI/R	BLUE WITH RED TRACER
BI/W	BLUE WITH WHITE TRACER
BI/Y	BLUE WITH YELLOW TRACER
BR/B	BROWN WITH BLACK TRACER
BR/W	BROWN WITH WHITE TRACER
O/B	ORANGE WITH BLACK TRACER
O/R	ORANGE WITH RED TRACER
O/W	ORANGE WITH WHITE TRACER
O/Y	ORANGE WITH YELLOW TRACER
P/W	PINK WITH WHITE TRACER
R/B	RED WITH BLACK TRACER
R/W	RED WITH WHITE TRACER
W/B	WHITE WITH BLACK TRACER
W/BL	WHITE WITH BLUE TRACER
W/G	WHITE WITH GREEN TRACER
W/R	WHITE WITH RED TRACER
W/Y	WHITE WITH YELLOW TRACER
Y/B	YELLOW WITH BLACK TRACER
Y/BL	YELLOW WITH BLUE TRACER
Y/G	YELLOW WITH GREEN TRACER
Y/R	YELLOW WITH RED TRACER
Y/W	YELLOW WITH WHITE TRACER

**FUSE BOX**

1.	HEAD HI	15A
2.	HEAD LO	15A
3.	FUEL	10A
4.	IGNITION	10A
5.	SIGNAL	15A
6.	FAN	15A
7.	SIDE STAND RELAY	
8.	FLASHER RELAY	

	DRAFTING STANDARD AS1000	DRAWN: RBS CHECKED: VVK	<b>NAVAL SHIP DESIGN Pty Ltd</b> PO Box 5016 Cairns QLD 4870 AUSTRALIA Ph: +617 4053 7091 Fax: +617 4053 7380 Email: msd@msd.com.au	
	UNLESS OTHERWISE STATED, DIMENSIONS IN MILLIMETRES	PASSED: MIS APPROVED:	SHIP: 2004 SUZUKI DL650 TITLE: ELECTRICAL SCHEMATIC (EXCEPT UK & EU MODELS)	SCALE: NTS DRAWING NUMBER: C0023/2
DO NOT SCALE	DATE APP: 28 April 2004	CONTRACTOR: DCCM	PROJECT CODE:	SHEET: 1 OF 1 REV: F

DRAWING NUMBER: **N0023/4**  
 SHT 1 OF 1  
 REV **E**  
 SECY CLASS: UNCLASSIFIED

REV	DATE	DRN	APP	DESCRIPTION OF REVISION	ZONE	REF	THOR
A	25-05-04	RBS	MIS	HEATED GRIPS CIRCUIT CORRECTED			
B	09-06-04	RBS	MIS	O/B IN WIRE COLOUR CODE CORRECTED	L	2	
C	12-06-04	RBS	MIS	IGNITION SWITCH WIRING CORRECTED (IG & O/G WIRES ADDED)			
D	08-07-04	RBS	MIS	ABBREVIATIONS ADDED & TACHO WIRE COLOUR CORRECTED			
E	12-10-04	RBS	MIS	FLASHER RELAY CLARIFIED			

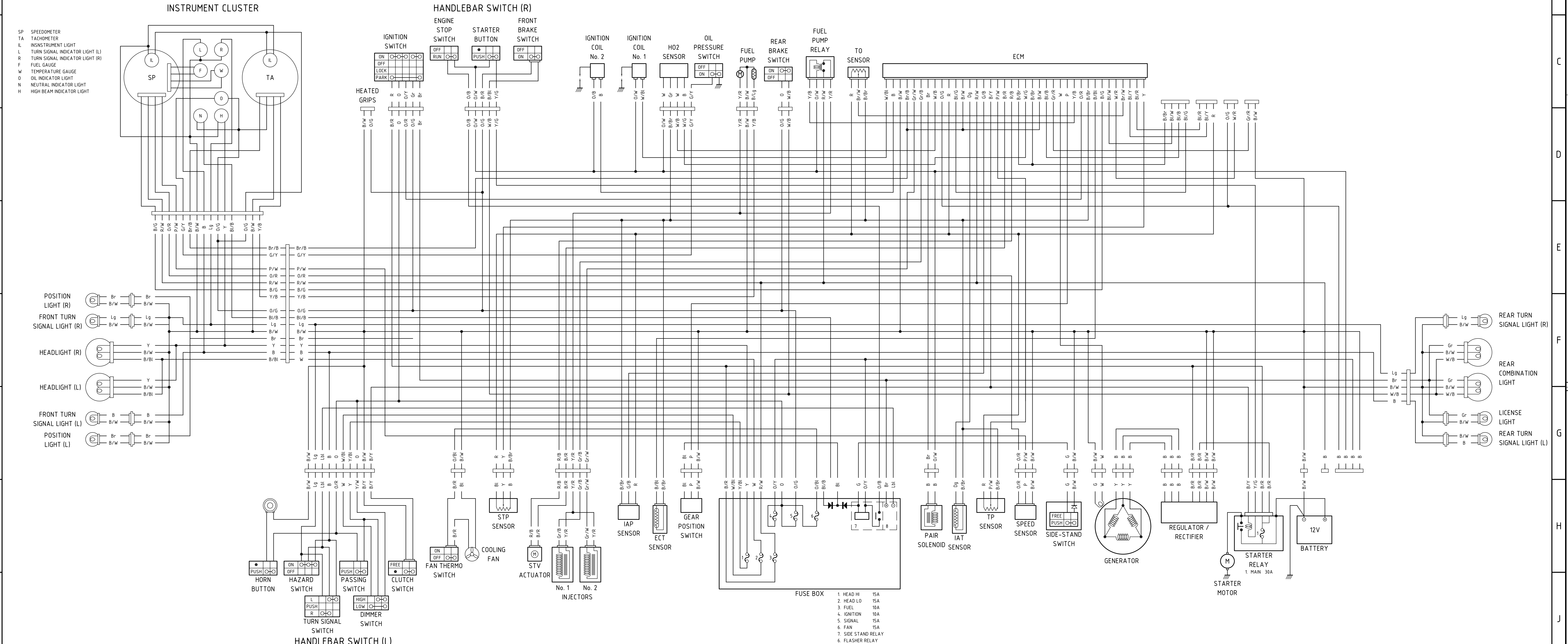

WIRE COLOUR CODE		SENSOR ABBREVIATIONS	
B	BLACK	B/BL	BLACK WITH BLUE TRACER
BL	BLUE	B/BR	BLACK WITH BROWN TRACER
BR	BROWN	B/G	BLACK WITH GREEN TRACER
Dg	DARK GREEN	B/O	BLACK WITH ORANGE TRACER
G	GREEN	B/R	BLACK WITH RED TRACER
Gr	GRAY	B/W	BLACK WITH WHITE TRACER
Lt	LIGHT BLUE	B/Y	BLACK WITH YELLOW TRACER
Lg	LIGHT GREEN	B/BL	BLUE WITH BLACK TRACER
O	ORANGE	B/G	BLUE WITH GREEN TRACER
P	PINK	B/R	BLUE WITH RED TRACER
R	RED	B/W	BLUE WITH WHITE TRACER
W	WHITE	B/Y	BLUE WITH YELLOW TRACER
Y	YELLOW	Br/B	BROWN WITH BLACK TRACER
		Br/W	BROWN WITH WHITE TRACER
		G/B	GREEN WITH BLACK TRACER
		G/Y	GREEN WITH YELLOW TRACER
		Gr/B	GRAY WITH BLACK TRACER
		Gr/R	GRAY WITH RED TRACER
		Gr/W	GRAY WITH WHITE TRACER
		D/B	ORANGE WITH BLACK TRACER
		O/B	ORANGE WITH BLUE TRACER
		O/G	ORANGE WITH GREEN TRACER
		O/R	ORANGE WITH RED TRACER
		O/W	ORANGE WITH WHITE TRACER
		O/Y	ORANGE WITH YELLOW TRACER
		P/W	PINK WITH WHITE TRACER
		R/B	RED WITH BLACK TRACER
		R/W	RED WITH WHITE TRACER
		W/B	WHITE WITH BLACK TRACER
		W/BL	WHITE WITH BLUE TRACER
		W/G	WHITE WITH GREEN TRACER
		W/R	WHITE WITH RED TRACER
		Y/B	YELLOW WITH BLACK TRACER
		Y/BL	YELLOW WITH BLUE TRACER
		Y/G	YELLOW WITH GREEN TRACER
		Y/R	YELLOW WITH RED TRACER
		Y/W	YELLOW WITH WHITE TRACER

**FUSE BOX**

1	HEAD HI	15A
2	HEAD LO	15A
3	FUEL	10A
4	IGNITION	10A
5	SIGNAL	15A
6	FAN	15A
7	SIDE STAND RELAY	
	FLASHER RELAY	

	DRAFTING STANDARD AS1500	DRAWN: RBS CHECKED: VVK	<b>NAVAL SHIP DESIGN Pty Ltd</b> PO Box 5011 Cairns QLD 4870 Australia Ph: +61 7 4053 7091 Fax: +61 7 4053 7980 Email: nsd@snd.com.au	
	UNLESS OTHERWISE STATED, DIMENSIONS IN MILLIMETRES	PASSED: MIS APPROVED:	SHP: 2004 SUZUKI DL650 TITLE: ELECTRICAL SCHEMATIC (UK & EU MODELS)	SCALE: NTS
DO NOT SCALE	DATE APP: 21 May 2004	PROJECT CODE:	DRAWING NUMBER: <b>C0023/4</b>	SHT 1 OF 1
CONTRACTOR: DCM	CONTR. ORG No:	PROJECT CODE:	DCCM:	DOC TYPE: